

MERITOR® SUSPENSION FIELD MANUAL



WEAR ITEMS



EXPLODED VIEWS



APPLICATIONS



TECH TIPS





SUSPENSION FIELD MANUAL

With a comprehensive aftermarket suspension parts portfolio, you can trust Meritor to provide your business with the products and support needed to maintain uptime and keep your vehicles running on the road. This field manual offers a detailed view of highly popular rear truck and trailer suspensions on the road today. The included images will guide you through the various suspensions by application, to help you identify common wear items that frequently need replacement.

With the camera on your mobile device, you can scan the QR codes to access our interactive Visual Search tool for the full exploded views of the different suspension models.

For the complete suspension and components offering, visit **MeritorPartsXpress.com** or refer to the **PB9968** series Meritor Suspension catalog.

TABLE OF CONTENTS

5 LINE HAUL TRACTOR

- 6 Freightliner: FAS II AirLiner®
- 8 Kenworth: AirGlide 100
- 10 Kenworth: AirGlide 200®–400®
- 12 Mack®/Volvo: Corporate Air
- 14 Navistar/International®: Corporate Air
- 16 Peterbilt: Air Leaf
- 18 Peterbilt: Air Trac
- 20 Peterbilt: AirGlide 210
- 22 Peterbilt: FLEX Air

25 LINE HAUL TRAILER

- 26 Hendrickson: INTRAAX®
- 28 Hutch: H7700/9700
- 30 Meritor®: RHP/MPA RideSentry
- 32 SAF Holland: CBX23/25
- 34 SAF Holland: Duralite (Binkley)

37 DUMP TRUCKS

- 38 Chalmers: 800 Series
- 40 Freightliner: TufTrac®
- 42 Hendrickson: HAULMAAX®
- 44 Hendrickson: HN®
- 46 Hendrickson: RT®
- 48 Mack: SS44 Series, Camelback

51 REFUSE TRUCKS

- 52 Freightliner: TufTrac®
- 54 Hendrickson: HAULMAAX®
- 56 Hendrickson: HN®
- 58 Mack: SS44 Series, Camelback

61 CONCRETE TRUCKS

- 62 Chalmers: 800 Series
- 64 Hendrickson: PRIMAAX®
- 66 Hendrickson: RS®
- 68 SAF Holland: AD-123 (Neway)

71 VOCATIONAL TRAILERS

- 72 Hutch: H900
- 74 Meritor®: MTA
- 76 Reyco: 21B

79 HOW TO IDENTIFY YOUR REAR TRUCK AND TRAILER SUSPENSION

- 80 Rear Truck Air Suspension
- 82 Trailer Four Spring Tandem Axle Suspension
- 83 Single Point or Two Spring Tandem Axle Suspension
- 84 Trailer Trailing Arm Air Suspensions
- 85 Truck Bolster Spring Suspensions

87 HENDRICKSON COMPONENTS

- 88 Ultra Rod® (Truck Suspension Only)
- 90 Uni-Rod® Kits: Individual Components
- 92 INTRAAX® Series Air Spring Selection Guide
- 94 INTRAAX® Selection Guides

97 HEIGHT CONTROL VALVES

- 98 Height Control Valve Selection Process
- 100 Height Control Valve Definitions

SUSPENSION OVERVIEW

SUSPENSION FUNCTION

- Carry the load
- Provide stability against side sway
- Transfer driving and braking forces between frame and axles
- Produce suitable riding and cushioning properties
- Maintain axle alignment
- Distribute the load across multiple axles

SUSPENSION COMPONENTS

- The suspension relies on all components working in harmony to perform its function.
- When one component gets worn, the stress transfer to other components causes accelerated wear on these parts.
- Early detection of any worn part will prevent major repairs and provide long-term savings.





LINE HAUL TRACTOR



**FREIGHTLINER:
FAS II AIRLINER®**



**KENWORTH:
AIRGLIDE 100**



**KENWORTH:
AIRGLIDE 200®-400®**



**MACK®/VOLVO:
CORPORATE AIR**



**NAVISTAR/
INTERNATIONAL®:
CORPORATE AIR**



**PETERBILT:
AIR LEAF**



**PETERBILT:
AIR TRAC**



**PETERBILT:
AIRGLIDE 210**



**PETERBILT:
FLEX AIR**



Truck, Drive Axle, Air Ride, Single or Tandem Axle, Requires Transverse Torque Arm



FAS II AirLiner is the most common Freightliner suspension on the road today, especially on highway tractors. This air ride suspension can be found on everything from long haul over the road trucks to smaller straight trucks. The suspension features a spring eye bushing connected to a “hockey stick” style spring.

Exploded View

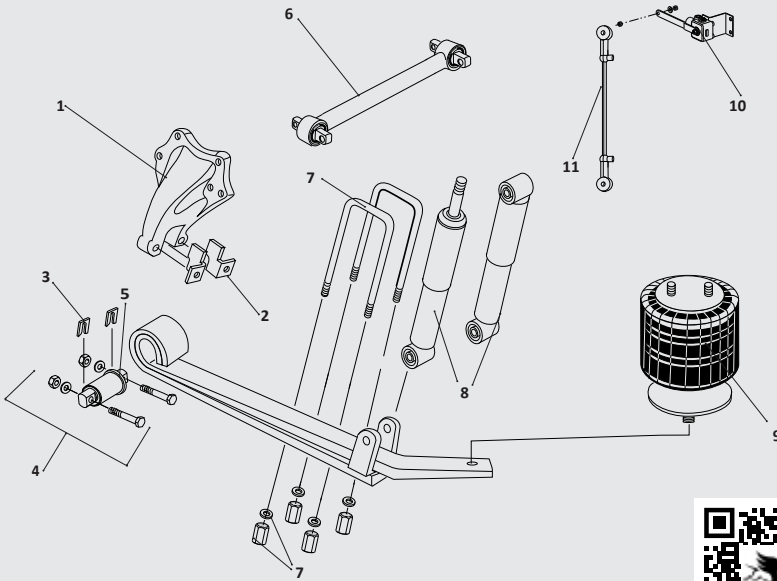

SCAN FOR VISUAL SEARCH ON MERITORPARTSXPRESS.COM

WEAR ITEMS

Spring eye bushing wear and walk out. Air springs, shocks and Height Control Valve (HCV).



TECH TIP

Newer designed spring eye bushings include a shoulder to reduce bushing walkout.

KEY NO.	MERITOR PART NO.	MACH PART NO.	OEM REFERENCE	DESCRIPTION	QTY. PER TANDEM
1	-	G-16649	16-13901-000	Hanger, Ductile Iron, Standard Flange - 1 1/4" Thick	2
2	R308803	G-8803	681-325-22-09	Hanger Wear Pad, Right Hand	2
	R308802	G-8802	681-325-21-09	Hanger Wear Pad, Left Hand	2
	-	G-16651	16-16456-001	Hanger Wear Pad, Right Hand, Use With Anti-Walk Bushing R3015541	2
	-	G-16652	16-16456-000	Hanger Wear Pad, Left Hand, Use With Anti-Walk Bushing R3015541	2
3	R308805	G-8805	681-328-13-84	Alignment Shim, 1/8"	As Required
	R308806	G-8806	681-328-21-84	Alignment Shim, 1/16"	As Required
	R308809	-	681-328-16-84	Alignment Shim, 1/16" Thick x 4 3/8" L.	As Required
	R308810	-	681-328-19-84	Alignment Shim, 1/8" Thick x 4 3/8" L.	As Required
4	R3017005	-	-	Front Pivot Bushing Kit, Includes Bushing, Bolts, Washers, and Nuts	2
5	R3015541	G-15541	16-16412-001	Spring Eye Bushing, Anti-Walk	2
6	R3015536	G-15536	681-326-67-16	Rigid Torque Arm, 23 15/16" Center-to-Center, R3015536 Includes R305275 Bushings	1
	R3015542	-	16-16749-002	Rigid Torque Arm, 24 3/8" Center-to-Center, R3015542 Includes R305275 Bushings	1
7	R30U8267-153	-	681-325-03-25	U-Bolt Assembly, Special Bend, 7/8"-14 Thd. x 5 3/16" Wide x 15 3/8" Long	4
8	M85319	-	681-326-04-00	Shock Absorber	2
	M89428	-	681-326-04-00	Shock Absorber, Premium Adjustable	2
	M85724	-	16-13957-000	Shock Absorber	2
9	FS9781	-	681-320-00-17, 16-14004-000, 16-16773-000	Firestone Air Spring	2
	MAF9781	-	681-320-00-17, 16-14004-000, 16-16773-000	Meritor Air Spring	2
	FS9780	-	16-14377-000	Firestone Air Spring	2
	MAF9780	-	16-14377-000	Meritor Air Spring	2
10	R309624	-	H00500C	Universal Height Control Valve, Hadley Model 500, Apply Air To Dump	1
	R3014731	-	H01501UD	Universal Height Control Valve, Hadley Next Gen, Apply Air To Dump	1
11	R309625	-	HPB450-3	Universal Leveling Valve Link Kit	1

For the complete suspension and components offering, visit MeritorPartsXpress.com or check out the PB9968 series of the Suspension catalog on Meritor.com/LOD.



Truck, Drive Axle, Air Ride, Tandem Axles



AirGlide 100 is an air suspension that is of the parallelogram style, commonly known as the 8 bag suspension. The suspension features eight air bags that pivot on two stabilizer rods connected to a central support bracket.

Exploded View

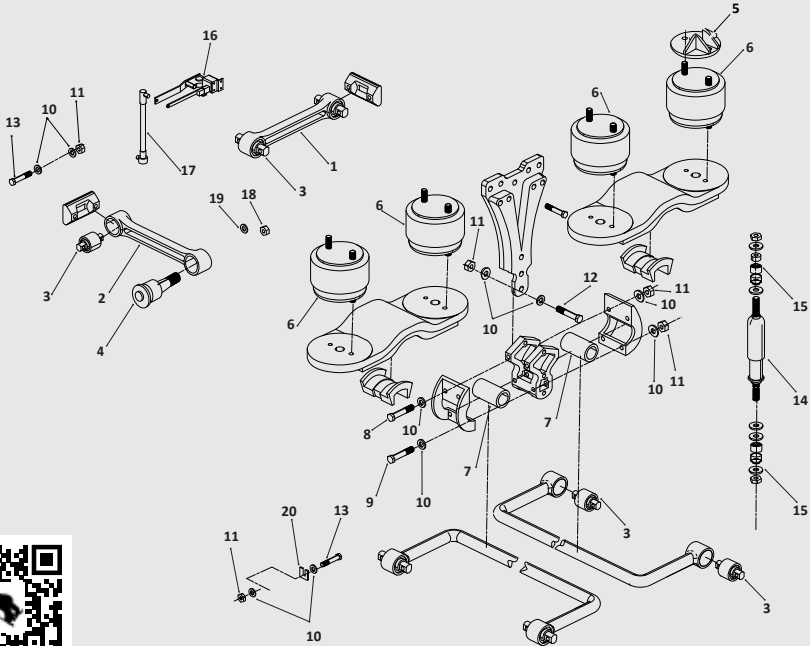

SCAN FOR VISUAL SEARCH ON MERITORPARTSPRESS.COM

WEAR ITEMS

Stabilizer/torsion bar bushing, air springs, shocks, Height Control Valve (HCV).



TECH TIP

Loose fasteners that are allowed to operate for any period of time will result in irreversible damage. Retightening a worn fastener will not correct a situation created by loose operation. It is imperative that fastener and other affected parts including bushings be replaced.

KEY NO.	MERITOR PART NO.	MACH PART NO.	OEM REFERENCE	DESCRIPTION	QTY. PER TANDEM
1	R3015708	-	K195-375; 925031	Torque Arm, 24" Center-to-Center, R302226 Bushings	2
2	R3015611	G-15611	925150	Torque Arm, 25" Center-to-Center, R302226 Bushings	2
	R3015711	-	K195-376; 944270	Torque Arm, 24" Center-to-Center, Includes R3010303 Straddle Mount Bushing and R30228 Tapered Stud Bushing	2
3	R3010303	G-10303	836940; 839310	Torque Arm & Stabilizer Rod Bushing, Rubber, Straddle Mount	8
	R302226	-	227720	Torque Arm & Stabilizer Rod Bushing, Rubber, Straddle Mount	8
	R307639	-	-	Torque Arm & Stabilizer Rod Bushing, Poly, Straddle Mount	8
	R304664	-	227722	Torque Arm Bushing, Straddle Mount, Aluminum Pin	8
4	R302228	-	229610	Torque Arm Bushing, Rubber, Tapered Stud	2
	R308651	-	-	Torque Arm Bushing, Poly, Tapered Stud	2
5	R305075	-	K048-449	Air Spring Bracket	8
6	FS9422	-	K303-6; K303-14; K303-15	Firestone Air Spring to 1994	8
	MAF9422	-	K303-6; K303-14; K303-15	Meritor Air Spring to 1994	8
	FS9616	-	K303-16	Firestone Air Spring with Bracket, 1995 and up	8
	MAF9616	-	K303-16	Meritor Air Spring with Bracket, 1995 and up	8
7	R304669	G-4669	K066-58; K066-50	Stabilizer Bushing, Rubber	4
	R307446A	-	K066-449	Stabilizer Bushing, Poly	4
8	R3016690	-	K041-724-260P	Stabilizer Bar Mounting Bolt, Top of Bracket, M20-2.5 x 260mm Long	4
9	R3016226	-	K041-717-160P	Stabilizer Bar Mounting Bolt, Bottom of Bracket, M16-2.0 x 160mm Long	4
10	R302547	-	-	Washer for 16mm bolt	As Required
	R3016686	-	-	Washer for 20mm bolt	As Required
11	R308841	-	-	Lock Nut, M16-2.0	As Required
	R3016229	-	-	Lock Nut, M20-2.5 mm	As Required
12	R3016415	-	-	Stabilizer Block Mounting Bolt, M16-2.0 x 170mm Long, Fabricated Hanger Bracket	6
13	R3016230	-	K041-712-130P	Stabilizer End Mounting Bolt, M16-2.0 x 120mm	8
	R3016225	-	K041-712-150P	Stabilizer End Mounting Bolt, M16-2.0 x 150mm	8
14	M85310	-	K374-87	Shock Absorber	4
	M89423	-	K374-7, K374-9, K374-29	Shock Absorber, Premium Adjustable	4
15	R307474	-	CA368-6	Shock Bushing, Poly, For Stud Mounted Shocks	16
16	R309624	-	H00500C	Universal Height Control Valve, Hadley Model 500, Apply Air To Dump	1
	R3014731	-	H01501UD	Universal Height Control Valve, Hadley Next Gen, Apply Air To Dump	1
17	R309625	-	-	Universal Linkage Kit	1
18	R302017	-	49NE2012	Torque Arm Mounting Nut For Tapered Pin Bushing	2
19	R302018	-	-	Torque Arm Washer, 1 5/16" ID	2
20	R305076	-	K21-922-3	Alignment Shim, 1/8" Thick	As Required

For the complete suspension and components offering, visit MeritorPartsXpress.com or check out the PB9968 series of the Suspension catalog on Meritor.com/LOD.



Truck, Drive Axle, Air Ride, Tandem Axles



AirGlide 200–400 is an air suspension that is of the parallelogram style, commonly known as the 8 bag suspension and is the latest generation of the AirGlide system. The suspension features eight air bags that pivot on two stabilizer rods connected to a central support bracket. The AirGlide 200–400 is commonly found on Newer Kenworth Tractors used in line haul applications.

Exploded View

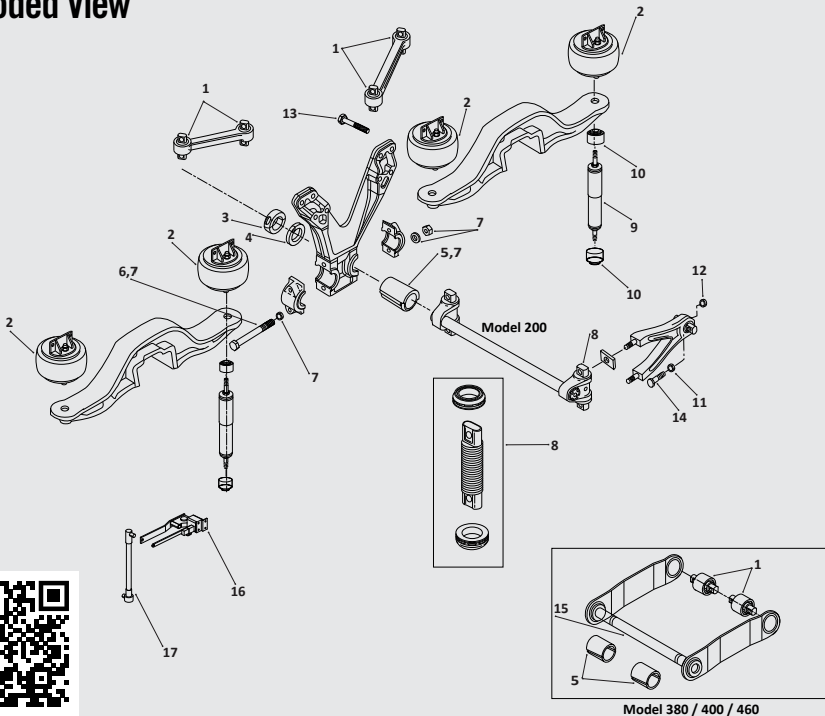

SCAN FOR VISUAL SEARCH ON [MERITORPARTSEXPRESS.COM](https://www.meritorpartsexpress.com)

WEAR ITEMS

Stabilizer/torsion bar bushing, air springs, shocks, Height Control Valve (HCV).



✂ TECH TIP

Loose fasteners that are allowed to operate for any period of time will result in irreversible damage. Retightening a worn fastener will not correct a situation created by loose operation. It is imperative that fastener and other affected parts including bushings be replaced.

KEY NO.	MERITOR PART NO.	MACH PART NO.	OEM REFERENCE	DESCRIPTION	QTY. PER TANDEM
1	R3010303	G-10303	836940	Torque Arm & Stabilizer Rod Bushing, Rubber, Straddle Mount	8
2	FS9617	-	K303-18	Firestone Air Spring	8
	FS9618	-	K303-19	Firestone Air Spring	8
	FS9622	-	K303-22	Firestone Air Spring	8
	MAF9622	-	K303-22	Meritor Air Spring	8
	FS9625	-	K303-25	Firestone Air Spring	8
	MAF9625	-	K303-25	Meritor Air Spring	8
	FS9547	-	C81-1004	Firestone Air Spring	8
	FS9541	-	C81-1005	Firestone Air Spring	8
3	-	G-16115	K220-598	Collar Assembly, 54 mm Bar Dia, 40K Models	4
4	-	G-15618	K066-502-1; K066-454	Thrust Bearing, 54 mm Bar Dia	4
	-	G-16112	K066-502-2; K066-461	Thrust Bearing, 58 mm Bar Dia	4
5	-	G-16107	K066-450	Torsion Bar Bushing, 54 mm Bar Dia, 40K Models, Rubber, Old Style	4
	R3010302	-	-	Torsion Bar Bushing, 54 mm Bar Dia, 40K Models, Poly	4
	R3016091	-	C13-1004	Torsion Bar Bushing, 54 mm Bar Dia, 40K Models, Rubber, Improved OE Version	4
	-	G-16108	K066-460	Torsion Bar Bushing, 58 mm Bar Dia, 46K Models, Rubber, Old Style	4
	R3016122	-	-	Torsion Bar Bushing, 58 mm Bar Dia, 46K Models, Poly	4
	R3016092	-	C13-1005	Torsion Bar Bushing, 58 mm Bar Dia, 46K Models, Rubber, Improved OE Version	4
6	R3016231	-	K041-712-290P	Bolt, M16-2.0 x 290 mm Long	4
7	R3016119	-	C13-1006	Torsion Bar Service Kit, 54 mm Bar, 40K Models, Includes (4) R3016091 Bushings, (4) R3016231 Bolts and Nuts	1
	R3016093	-	C13-1007	Torsion Bar Service Kit, 58 mm Bar, 46K Models, Includes (4) R3016092 Bushings, (4) R3016231 Bolts and Nuts	1
8	-	G-16117	K345-5156; K345-5032	Threaded Pin Service Kit, Includes (2) Threaded Pins and Seals	2
9	M85900	-	70701; 665944; 665903	Shock Absorber	4
	M85902	-	665950; 665945; 665906	Shock Absorber	4
	M85936	-	C71-1014; 671962	Shock Absorber	4
	M89456	-	C71-1014; 671962	Shock Absorber, Premium Adjustable	4
	M85937	-	C71-1015; 671963	Shock Absorber	4
10	R307474	-	-	Shock Bushing, Poly, For Stud Mounted Shocks	8
11	R302547	-	-	Washer, 5/8" ID, Use with M16 Bolts	16
12	R308841	-	-	Lock Nut, M16 - 2.0	16
13	R3016226	-	K041-712-160P	Bolt, M16 - 2.0 x 160mm Long, Top Row of Hanger	8
14	R3016230	-	K041-712-120P	Bolt, M16 - 2.0 x 120mm Long	8
15	-	G-16718	C65-1000; C65-1013	Sway Bar Assembly, 58 mm Bar, Includes G-10303 Bushings, For Air Glide 200, 52" Axle Spacing	2
16	R309624	-	H00500C	Universal Height Control Valve, Hadley Model 500, Apply Air To Dump	1
	R3014731	-	H01501UD	Universal Height Control Valve, Hadley Next Gen, Apply Air To Dump	1
17	R309625	-	-	Universal Linkage Kit	1

For the complete suspension and components offering, visit MeritorPartsXpress.com or check out the PB9968 series of the Suspension catalog on Meritor.com/LOD.



Truck, Drive Axle, Air Ride, Single or Multiple Axles, Transverse Torque Arm



Mack/Volvo Corporate is the most common suspension used on their newer vehicles. This air ride suspension can be found on everything from long haul over the road trucks to smaller straight trucks. The suspension features a “Z” style spring connected to a torque leaf which attaches to the hanger. The Z spring rests in the hanger against a special wear pad. The suspension also requires a transverse torque rod. There are three different hangers and torque leaf designs used with this suspension and are grouped by the years used in production. Below is a drawing of each hanger and the years in service.

Exploded View

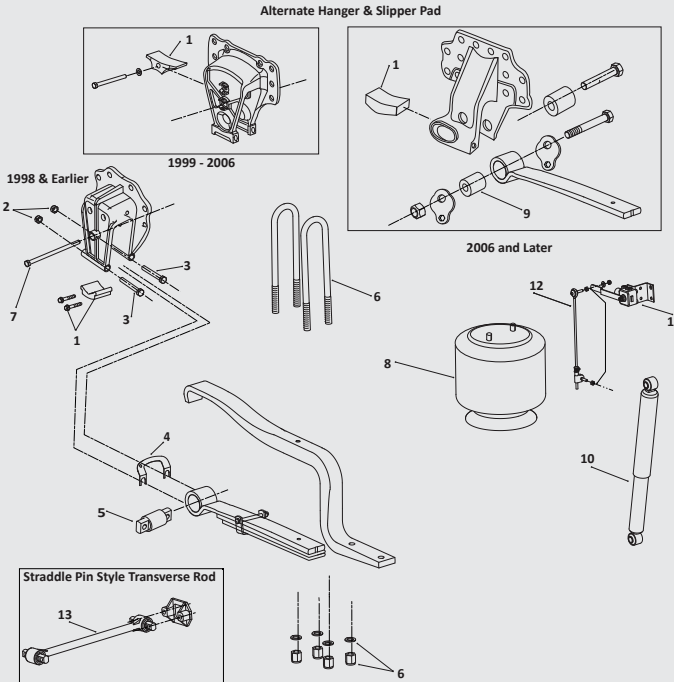

SCAN FOR VISUAL SEARCH ON MERITORPARTSEXPRESS.COM

WEAR ITEMS

Wear pad, torque arm/leaf bushing, air springs, shocks and Height Control Valve (HCV).



KEY NO.	MERITOR PART NO.	MACH PART NO.	OEM REFERENCE	DESCRIPTION	QTY. PER TANDEM
1	R308819	-	8027423; 8061971	Wear Pad Kit, Includes Mounting Screws, Prior to 1999	2
	R3016778	-	8079889; 20568741	Wear Pad Kit, Through 2006	2
	R3016779	-	20703083	Wear Pad Kit, 2007 and Later	2
2	R308911	-	V8397202	Flange Nut, 5/8"-11, Through 2006	4
3	R308909	-	V8397091	Bolt, 5/8"-11 x 6" Long, Through 2006	4
	R308910	-	V8397092	Bolt, 5/8"-11 x 6 5/8" Long, Through 2006	4
4	R305281	-	V8020329	Alignment Shim	2
5	R302225	-	35033-3201	Spring Eye Bushing, Straddle Mount, 2 1/2" OD, 4 3/8" Center to Center, 5/8" Bolt Holes	2
	R3015671	G-15671	8079894	Spring Eye Bushing, High Confinement, Straddle Mount, 2 1/2" OD, 4 3/8" Center to Center, 5/8" Bolt Holes	2
6	R30U8151-16	-	V8027431	U-Bolt Assembly, Rd. Bend, 3/4"-16 Thd. x 3" Wide x 16" Long	4
7	-	G-16806	35026-0001; 8027436	Rebound Pin, 3/4" OD X 5 1/4" Long	2
8	FS9219	-	35003-3204; 35003-3209	Firestone Air Spring	2
	FS8829	-	20505399	Firestone Air Spring	2
	MAF8829	-	20505399	Meritor Air Spring	2
	FS9296	-	8061151	Firestone Air Spring	2
9	R3016777	-	20558810	Spring Eye Bushing, Through Hole, After 2006, 7/8" ID x 2 9/16" OD x 3 9/16" Long	2
10	M85024	-	8071524	Shock Absorber	2
	M85046	-	8026658	Shock Absorber	2
	M85047	-	8169859	Shock Absorber	2
11	R309624	-	H00500C	Universal Height Control Valve, Hadley Model 500, Apply Air To Dump	1
	R3014731	-	H01501UD	Universal Height Control Valve, Hadley Next Gen, Apply Air To Dump	1
12	R307852	-	-	Leveling Valve Link Kit	1
13	R308821	-	35801-0068	Torque Arm, 22 1/8" Long, Straddle Mount Bushings, R308821 Includes R309395 Bushings	1
	R303176	-	-	Torque Arm Kit, Full Ball Design	1

For the complete suspension and components offering, visit MeritorPartsXpress.com or check out the PB9968 series of the Suspension catalog on Meritor.com/LOD.



Truck, Drive Axle, Air Ride, Single or Multiple Axles, Transverse Torque Arm



Navistar Corporate Air Suspension is the most common Navistar suspension used on their vehicles and includes a large opening in the center of the hanger for weight reduction purposes. This air ride suspension can be found on everything from line haul over the road trucks to smaller straight trucks. The suspension features a spring eye bushing connected to a “hockey stick” style spring. The suspension also requires a transverse torque rod.

Exploded View

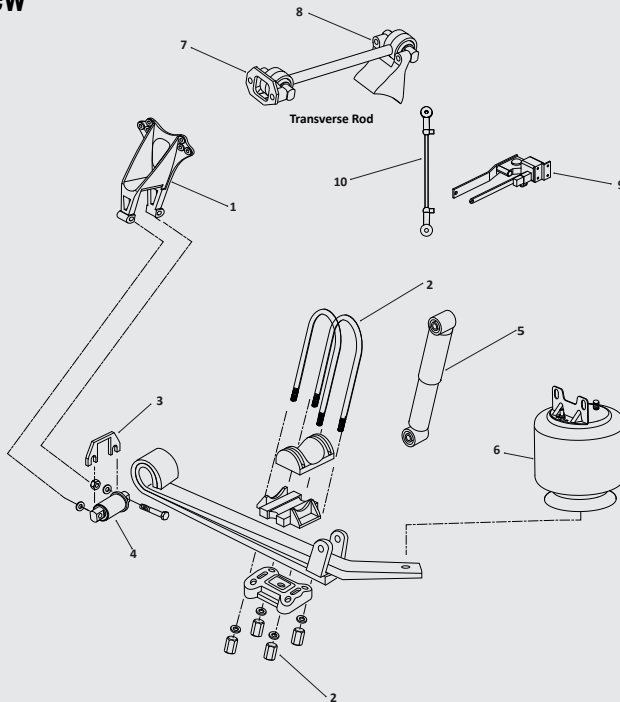

SCAN FOR VISUAL SEARCH ON [MERITORPARTSEXPRESS.COM](https://www.meritorpartsexpress.com)



WEAR ITEMS

Spring eye bushing wear and walk out. Air springs, shocks and Height Control Valve (HCV) (uses the same spring eye bushing as Freightliner FAS II AirLiner).

KEY NO.	MERITOR PART NO.	MACH PART NO.	OEM REFERENCE	DESCRIPTION	QTY. PER TANDEM
1	-	G-16812	3545280C1; 3544131C2	Hanger, Most Models	2
2	R30U8169-156	-	-	U-Bolt Assembly, Rd. Bend, 7/8"-14 Thd. x 5 1/2" Wide x 15 3/4" Long	4
	R30U8169-166	-	3538842C1	U-Bolt Assembly, Rd. Bend, 7/8"-14 Thd. x 5 1/2" Wide x 16 3/4" Long	4
3	R3016687	-	65640-002	Shim, 1/16" Thick	As Required
4	R3015541	G-15541	3538115C5	Spring Eye Bushing, Anti-Walk	2
	-	G-15600	-	Spring Eye Bushing, Anti-Walk, .050" Oversize OD	As Required
5	M85931	-	3573265C1	Shock Absorber	2
	M89458	-	-	Shock Absorber, Premium Adjustable	2
6	FS1191	-	3541731C1	Firestone Air Spring, Includes Bracket	2
	MAF1191	-	3541731C1	Meritor Air Spring, Includes Bracket	2
7	R302634	-	22186-000	Transverse Torque Arm Mounting Bracket	1
8	R3016075	-	3580088C1; 3548381C1	Transverse Torque Arm, 25 3/8" Center-to-Center, Not Rebusable	1
9	R3014731	-	H01501UD	Universal Height Control Valve, Hadley Next Gen, Apply Air To Dump	1
10	R309625	-	HPB450-3	Linkage Kit, Universal	1

For the complete suspension and components offering, visit MeritorPartsXpress.com or check out the PB9968 series of the Suspension catalog on Meritor.com/LOD.



Truck, Drive Axle, Air Ride, Single or Multiple Axles, Transverse Torque Arm



The Air Leaf is an air ride suspension with a distinctive paddle and leaf spring combination supporting the air spring. The suspension supporting a spring eye bushing housed in a spring eye pivot that is bolted directly to the leaf spring which also replaces the standard torque rod. The suspension also requires a transverse torque rod.

Exploded View

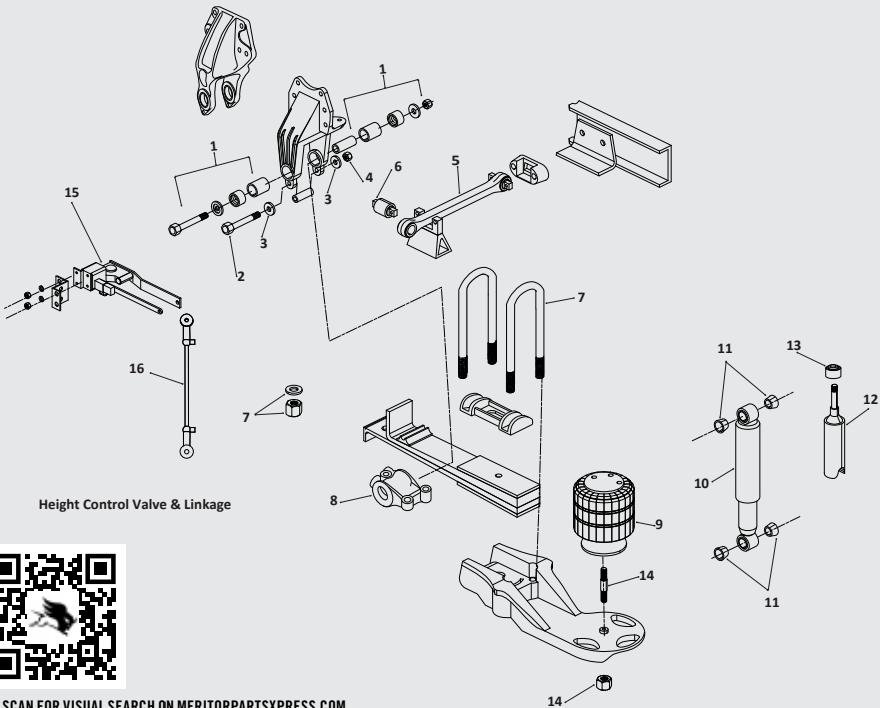

WEAR ITEMS

Spring eye bushing and connecting parts, air springs, shocks and Height Control Valve (HCV).



KEY NO.	MERITOR PART NO.	MACH PART NO.	OEM REFERENCE	DESCRIPTION	QTY. PER TANDEM
1	R304773	-	03AL1	Spring Eye Bushing Kit, Includes Bushing, Spacers & Hardware	2
2	R301820	-	-	Bolt, 1/2" X 6 1/2" Long	2
3	R309603	-	-	Washer, 1/2" ID	2
4	R303560	-	-	Lock Nut, 1/2"-20	2
5	R304771	G-4771	03-04059	Torque Arm, 23" Center-to-Center, Newer Torque Arms Are Not Rebusable, Older Torque Arms Use R302225 Bushings	2
6	R302225	-	227710; 44694	Torque Arm Bushing, Rubber, Straddle Mount	4
	R307638	-	-	Torque Arm Bushing, Poly, Straddle Mount	4
7	R30U8375-14	-	03-03133-150	U-Bolt Assembly, Semi Rd. Bend, 1"-14 Thd. x 4 1/8" Wide x 14" Long	4
	R30U8375-154	-	03-03134-151	U-Bolt Assembly, Semi Rd. Bend, 1"-14 Thd. x 4 1/8" Wide x 15 1/2" Long	4
	R30U8255-05	-	03-04523	U-Bolt Assembly, Sq. Bend, 3/4"-16 Thd. x 4" Wide x 5" Long	2
8	R3011749	G-11749	03-01654	Spring Eye Pivot	2
9	FS9069	-	03-01649	Firestone Air Spring	2
	MAF9069	-	03-01649	Meritor Air Spring	2
10	M85308	-	03-04176	Shock Absorber	2
	M89424	-	03-04176	Shock Absorber, Premium Adjustable	2
11	R30401754	-	73D2002	Shock Bushing, Rubber, For Eye Mounted Shocks	As Required
	R307529	-	-	Shock Bushing, Poly, For Eye Mounted Shocks	As Required
12	M85311	-	03-04629	Shock Absorber	2
	M89422	-	03-04629	Shock Absorber, Premium Adjustable	2
13	R307474	-	-	Shock Bushing, Poly, For Stud Mounted Shocks	As Required
14	R307868	-	27-00173	Air Spring Stud Assembly, 1/2"-20 X 5" Long	2
15	R309624	-	H00500C	Universal Height Control Valve, Hadley Model 500, 3/8" Ports, Apply Air To Dump	1
	R3014731	-	H01501UD	Universal Height Control Valve, Hadley Next Gen, 3/8" Ports, Apply Air To Dump	1
	R3014732	-	H01501PUD	Universal Height Control Valve, Hadley Next Gen, 1/4" Ports, Apply Air To Dump	1
16	R309625	-	-	Universal Linkage Kit	1

For the complete suspension and components offering, visit MeritorPartsXpress.com or check out the PB9968 series of the Suspension catalog on Meritor.com/L0D.



Truck, Drive Axle, Air Ride, Single or Multiple Axles, Transverse Torque Arm



The Air Trac is an air ride suspension and similar to the Air Leaf with a distinctive paddle and leaf spring combination supporting the air spring but it is not rigidly attached to the hanger. The suspension features a lower torque rod that connects to the hanger and runs below the leaf spring to the axle. The older versions have eye mounted shocks while the newer versions have stud mounted shocks. The suspension also features a transverse torque rod.

Exploded View

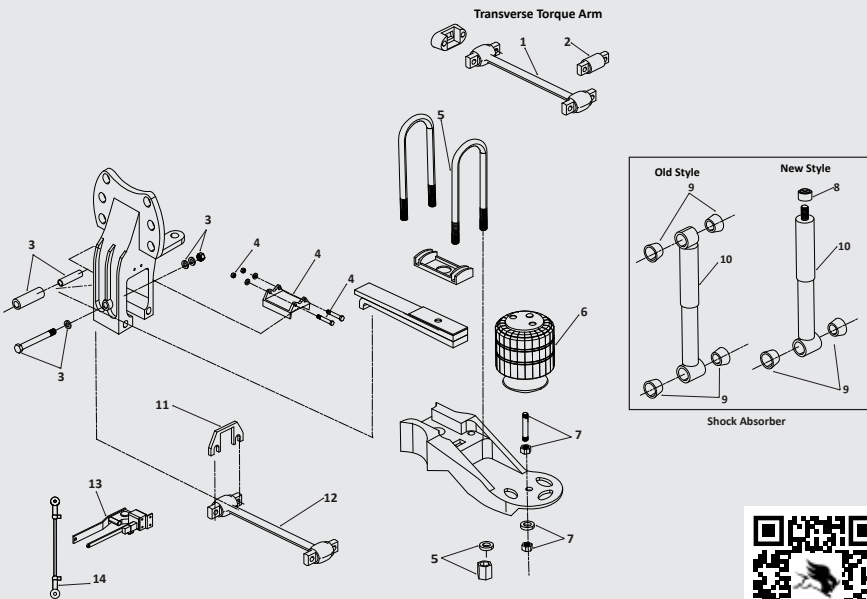

SCAN FOR VISUAL SEARCH ON MERITORPARTSEXPRESS.COM



WEAR ITEMS

Spring wear pad, torque rod bushing, air springs, shocks and Height Control Valve (HCV).



TECH TIP

Loose fasteners that are allowed to operate for any period of time will result in irreversible damage. Retightening a worn fastener will not correct a situation created by loose operation. It is imperative that fastener and other affected parts including bushings be replaced.

KEY NO.	MERITOR PART NO.	MACH PART NO.	OEM REFERENCE	DESCRIPTION	QTY PER TANDEM
1	R304771	G-4771	03-04059	Torque Arm, 23" Center-to-Center, Includes R302225 Bushings	2
2	R302225	-	227710; 44694	Torque Arm Bushing, Rubber, Straddle Mount	4
	R307638	-	-	Torque Arm Bushing, Poly, Straddle Mount	4
3	R307854	-	-	Spring Roller Bushing Kit Includes Bushing, Spacer, and Hardware	2
4	R307862	-	23-12566	Wear Pad Kit, 1/2" Bolts, Use With G-16711 Hanger	2
	-	G-15658	03-07296	Wear Pad Kit, 5/8" Bolts	2
5	R30U8375-14	-	03-03133-150	U-Bolt Assembly, Semi Rd. Bend, 1"-14 Thd. x 4 1/8" Wide x 14" Long	4
	R30U8375-154	-	03-03134-151	U-Bolt Assembly, Semi Rd. Bend, 1"-14 Thd. x 4 1/8" Wide x 15 1/2" Long	4
6	FS9069	-	03-01649; 03-02038; 03-02456	Firestone Air Spring	2
	MAF9069	-	03-01649; 03-02038; 03-02456	Meritor Air Spring	2
7	R307868	-	27-00173	Air Spring Stud Assembly, 1/2"-20 x 5" Long	2
8	R307474	-	-	Shock Bushing, Poly, For Stud Mounted Shocks	As Required
9	R30401754	-	-	Shock Bushing, Rubber For Eye Mounted Shocks	As Required
	R307529	-	-	Shock Bushing, Poly For Eye Mounted Shocks	As Required
10	M85308	-	03-04176	Shock Absorber	2
	M89422	-	03-04176	Shock Absorber, Premium Adjustable	2
	M85311	-	03-04629	Shock Absorber	2
	M89424	-	03-04629	Shock Absorber, Premium Adjustable	2
11	R305281	-	-	Torque Arm Shim, 1/16" Thick	As Required
12	R305082	G-5082	03-04119	Torque Arm with 5/8" Hole in Both Bushings, 17 11/32 Center-to-Center, Includes R302226 Bushings	2
	R305083	G-5083	03-04327	Torque Arm with 5/8" Hole Hanger End, 3/4" Hole Axle End, 17 11/32 Center-to-Center, Includes (1) R302226 and (1) R303868 Bushing	2
13	R309624	-	H00500C	Universal Height Control Valve, Hadley Model 500, 3/8" Ports, Apply Air To Dump	1
	R3014731	-	H01501UD	Universal Height Control Valve, Hadley Next Gen, 3/8" Ports, Apply Air To Dump	1
	R3014732	-	H01501PUD	Universal Height Control Valve, Hadley Next Gen, 1/4" Ports, Apply Air To Dump	1
14	R309625	-	-	Universal Linkage Kit	1

For the complete suspension and components offering, visit MeritorPartsXpress.com or check out the PB9968 series of the Suspension catalog on Meritor.com/LOD.



WEAR ITEMS

Spring eye bushing wear and walk out. Air springs, shocks and Height Control Valve (HCV) (uses the same spring eye bushing as Freightliner FAS II AirLiner).

KEY NO.	MERITOR PART NO.	MACH PART NO.	OEM REFERENCE	DESCRIPTION	QTY. PER TANDEM
1	R3016118	-	TR030020010	Torque Arm, 25 9/16" Center-to-Center, Not Rebushable	2
2	R3017006	-	-	Front Pivot Bushing Kit, Includes Bushing, Bolts, Washers, and Nuts	2
3	R3016687	-	Maybe use Hend 65640-2 HTB	Torque Arm Shim, 1/16" Thick	As Required
4	R3015541	G-15541	-	Spring Eye Bushing, Anti-Walk	2
	-	G-15600	-	Spring Eye Bushing, Anti-Walk, .050" Oversize	As Required
5	R30U8161-15	-	-	U-Bolt Assembly, Rd. Bend, 7/8"-14 Thd. x 3" Wide x 15" Long	-
6	FS8864	-	C81-1011	Air Spring	2
7	M85069	-	03-08781	Shock Absorber	2
8	R307474	-	-	Shock Bushing, Poly, For Stud Mounted Shocks	4
9	R3014731	-	H01501UD	Height Control Valve, Hadley Next Gen, Apply Air To Dump	1
10	R309625	-	HPD450-3	Universal Linkage Kit	1

For the complete suspension and components offering, visit MeritorPartsXpress.com or check out the PB9968 series of the Suspension catalog on Meritor.com/LOD.



Truck, Drive Axle, Air Ride, Single or Multiple Axles, Transverse Torque Arm



The FLEX Air is an air ride suspension that can easily be identified by the curved leaf spring running in front of the hanger and curving down to the axle. It features a torque rod running from the bottom of the hanger back to the axle. The suspension also requires a transverse torque rod.

Exploded View

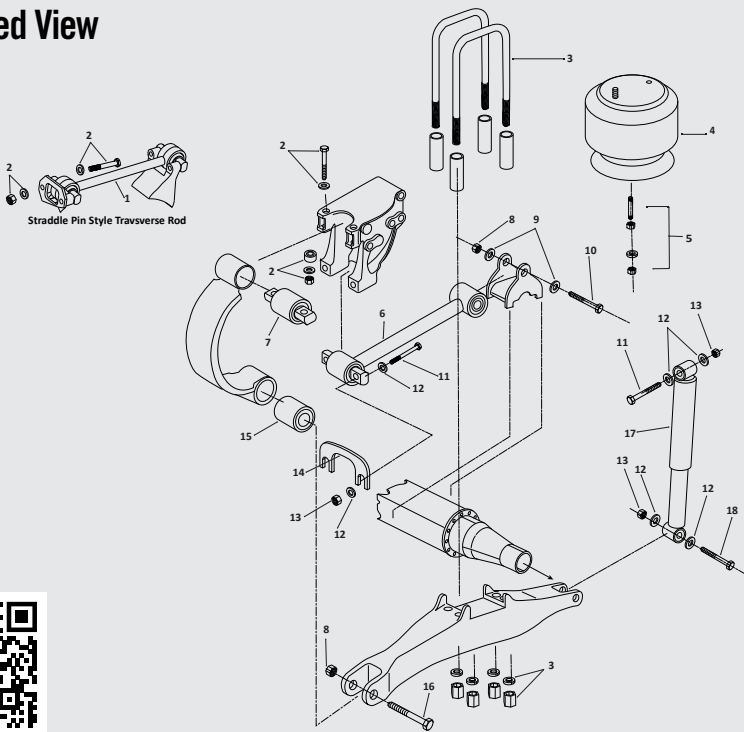

SCAN FOR VISUAL SEARCH ON MERITORPARTSEXPRESS.COM

WEAR ITEMS

Spring eye bushings, torque rod bushing, air springs, shocks and Height Control Valve (HCV).



TECH TIP

Loose fasteners that are allowed to operate for any period of time will result in irreversible damage. Retightening a worn fastener will not correct a situation created by loose operation. It is imperative that fastener and other affected parts including bushings be replaced.

KEY NO.	MERITOR PART NO.	MACH PART NO.	OEM REFERENCE	DESCRIPTION	QTY. PER TANDEM
1	R3015709	-	C65-6002; C65-6009	Transverse Torque Arm, 25 1/2" Center-to-Center, New Torque Arms Are Not Rebusable. Older Torque Arms Use R305275 Bushings	1
2	R3016088	-	-	Bolt Assembly, M16 - 2.0 x 150mm Long, Includes Bolt, Nut, Washers	As Required
	R3016105	-	-	Bolt Assembly, M16 - 2.0 x 160mm Long, Includes Bolt, Nut, Washers	As Required
3	R30U8268-134	-	C34-6000	U-Bolt Assembly, Sq. Bend, 7/8"-14 Thd. x 5 1/8" wide x 13 1/2" Long	4
4	FS8813	-	C81-6000	Firestone Air Spring	2
	MAF8813	-	C81-6000	Meritor Air Spring	2
5	R307868	-	27-00173	Air Spring Stud Assembly, 1/2"-20 x 5" Long, Includes Washer and 2 Nuts	2
6	R3016098	-	C65-6000-001	Torque Arm, Front, 23 3/4" Center-to-Center, Not Rebusable	2
	R3016099	-	C65-6000-002	Torque Arm, Rear, 24 5/8" Center-to-Center, Not Rebusable	2
7	R3016094	G-16094	C13-6001	Spring Eye Bar Pin Bushing	2
8	R301835	-	-	Lock Nut, 7/8"-14	4
9	R302546	-	-	Washer, 7/8" ID	4
10	R3015182	-	-	Torque Arm Bolt, 7/8"-14 x 5 1/2" Long	2
11	R3016224	-	-	Bolt, 5/8"-18 x 5 1/2" long, Replacement for OE 16MM Bolt	6
12	R302547	-	-	Washer, 5/8" ID	12
13	R301943	-	-	Lock Nut, 5/8"-18	8
14	R305281	-	-	Torque Arm Shim, 1/16" Thick	As Required
15	R3016097	-	C65-1002; C13-6002	Spring Eye Hollow Bushing	2
16	R303693	-	-	Bolt, 7/8"-14 x 6 1/2" Long	2
17	M85067	-	C71-6000	Shock Absorber	2
18	R303792	-	-	Bolt, 5/8"-18 x 4 1/2" Long	2

For the complete suspension and components offering, visit MeritorPartsXpress.com or check out the PB9968 series of the Suspension catalog on Meritor.com/LOD.





LINE HAUL TRAILER



**HENDRICKSON:
INTRAAX®**



**HUTCH:
H7700/9700**



**MERITOR®: RHP/MPA
RIDEENTRY**



**SAF HOLLAND:
CBX23/25**

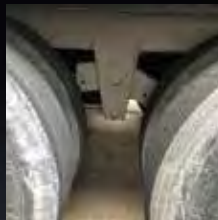

**SAF HOLLAND:
DURALITE (BINKLEY)**



Trailer, Air Ride, Single Axle



The INTRAAX/VANTRAAX/ULTRAA-K series of air spring suspensions comes in many different versions but all of them have a beam that is welded to the axle, thereby eliminating the need for U-bolts. The main identifying feature is the type of trailing arm used in the suspension and the width of the main (Tri-functional) bushing. There is a wide version (7.25" hanger width) and a narrow version (4.12" hanger width). Below are drawings of the three main versions of the trailing arm and the suspension types they can be found on.

Exploded View

AAL, AANL, AANLS, AAEDL

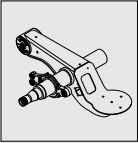

AANT & AAZNT

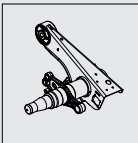

AAT, AAEDT

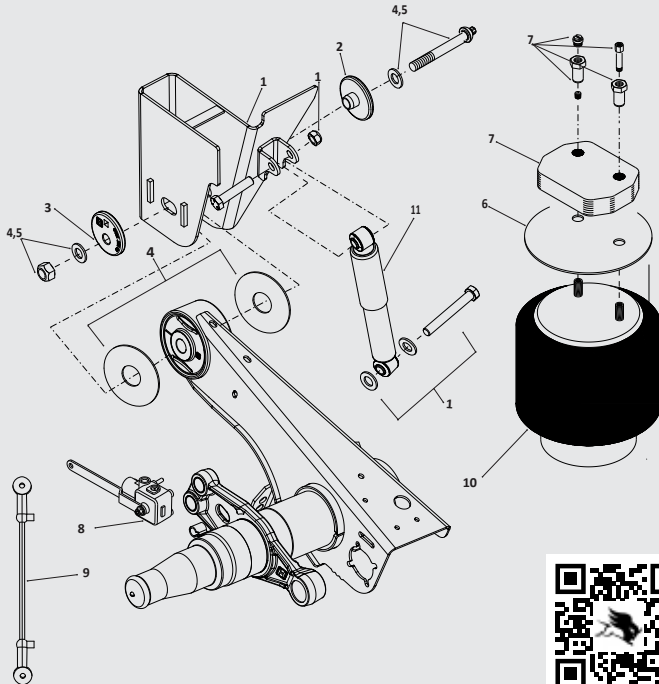
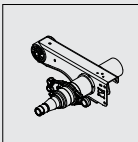

SCAN FOR VISUAL SEARCH ON MERITORPARTSEXPRESS.COM

WEAR ITEMS

Tri-functional bushing and adapters. Air springs, shocks and Height Control Valve (HCV).



TECH TIP

As a part of your routine maintenance, visually examine all trailer pivot connections by looking up at the bushing tube from under the trailer, specifically inspecting the voids and metal cores.

KEY NO.	MERITOR PART NO.	OEM REFERENCE	DESCRIPTION	QTY. PER TANDEM
1	R3016352	S-24757/2	Shock Bolt Kit, 5" Dia Axles for AAL, AAEDL AAZL Fronts; All HKA Models	2
	R3014780	S-2157/2	Shock Bolt Kit, AAL, AANL, AAEDL Rear	2
	R3014778	S-20031/2	Shock Bolt Kit, AAT Rear Mount, Includes Shock Spacer	2
2	R3010755	S-20924	Alignment Collar - Concentric (Inner) QUIK-ALIGN™	2
3	R3010754	S-20925	Alignment Collar - Eccentric (Outer) QUIK-ALIGN™	2
4	R3010729A	S-24691	Tri-Function Bushing Kit - QUIK-ALIGN™, Includes Bushing & Hardware, All Models with Wide Bushings	2
	R3014377	S-26321	Tri-Function Bushing Kit - QUIK-ALIGN™, Includes Bushing & Hardware, Does 1 Axle, All Models with Narrow Bushing	1
5	R3010730A	S-24679	Pivot Bolt Kit - QUIK-ALIGN™, 10 1/2" Long Bolt, All Models with Wide Bushings	2
	R3014635	S-24705	Pivot Bolt Kit - QUIK-ALIGN™, 7" Long Bolt, All Models with Narrow Bushing	2
6	R3014777	B-22510-4	Air Spring Spacer 3/4" Thick, Plastic	2
7	R3014342	S-22619/2	Air Spring Fitting Kit; w/out Plastic Spacer;	2
	R3014343	S-22630/2	Air Spring Fitting Kit; Use With 1 1/8 in. Thick Plastic Spacer	2
	R3014345	S-22632/2	Air Spring Fitting Kit; Use With 3 1/8 in. Thick Plastic Spacer	2
	R3014344	S-22631/2	Air Spring Mounting Kit, All HKA Models	2
	R3016368	S-22635/2	Air Spring Fitting Kit; Use With 3/4 in. Thick Plastic Spacer; All Models Except AAEDT	2
8	R3011855	VS-227	Height Control Valve	1
9	R3014789	S-14187	Linkage Kit	1
Not Shown	R309575	S-21307	Rebush tool (Wide Bushing), Except AANL & AANLS	As Required
	R3014634	S-24736	Rebush tool (Narrow Bushing), AANL & AANLS Models	As Required
10	See Page 92	Various	Air Spring Assembly	2
11	See Page 94	Various	Shock Absorber	2

For the complete suspension and components offering, visit MeritorPartsXpress.com or check out the PB9968 series of the Suspension catalog on Meritor.com/LOD.



Trailer, Leaf Spring, Single, Tandem or More Axles



H7700/9700 is the most common leaf spring suspension used on trailers. This suspension comes in multiple axle spacing configurations, 42" to 121", with the 42 1/2" and 49" being the most popular configurations. The H7700 models had two bolts attaching the equalizer through the hanger and was replaced in the mid 1990s by the H9700 which uses only one larger bolt to attach the equalizer. The suspension comes in two major variants the cast and fabricated version with the cast version providing better durability for heavy/severe duty applications.

Exploded View

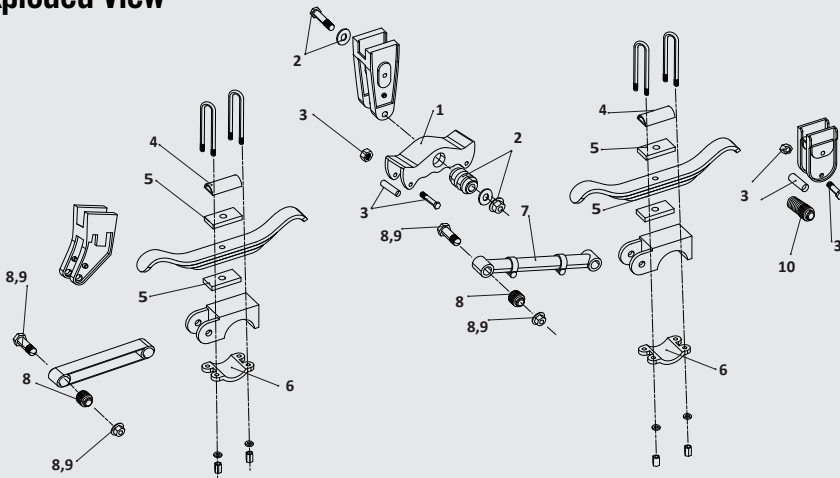

Series 10
Hanger/Equalizer Assembly

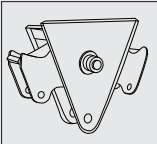

SCAN FOR VISUAL SEARCH ON MERITORPARTSEXPRESS.COM

WEAR ITEMS

Equalizer and bushing, torque arms.



TECH TIP

1. Loose fasteners that are allowed to operate for any period of time will result in irreversible damage. Retightening a worn fastener will not correct a situation created by loose operation. It is imperative that fastener and other affected parts including bushings be replaced.
2. Always carefully inspect the spring and axle clamp components for any signs of wear or cracks, and replace if visible wear or cracks are present.

KEY NO.	MERITOR PART NO.	MACH PART NO.	OEM REF.	DESCRIPTION	QTY. PER TANDEM
1	R3016393	-	16158-01	Equalizer, Fabricated, Rubber Bushing, One Bolt, O.E., 42 1/2 & 49" Axle Spacing	2
	R307532	G-7532	16158-01	Equalizer, Fabricated, Rubber Bushing, One Bolt, 42 1/2 & 49" Axle Spacing	2
	R309471	G-9471	17784-01	Equalizer, Cast, Rubber Bushing, One Bolt, 42 1/2 & 49" Axle Spacing	2
	R309567	-	-	Equalizer, Fabricated, Poly Bushing, One Bolt, 42 1/2 & 49" Axle Spacing	2
	R3016392	-	750-03	Equalizer, Fabricated, Rubber Bushing, Two Bolt, O.E., 42 1/2 & 49" Axle Spacing	2
	R302781	G-2781	-	Equalizer, Fabricated, Rubber Bushing, Heavy Duty, Two Bolts, Includes Wear Plates, 42 1/2 & 49" Axle Spacing	2
	R302781A	G-2781A	750-03	Equalizer, Fabricated, Rubber Bushing, OE Equivalent, Two Bolt, 42 1/2 & 49" Axle Spacing	2
	R309570	G-9570	750-03	Equalizer, Fabricated, Rubber Bushing, Standard Duty, Two Bolt, 42 1/2 & 49" Axle Spacing	2
	R307918	-	-	Equalizer, Fabricated, Poly Bushing, Two Bolt, 42 1/2 & 49" Axle Spacing	2
	R302889	G-2889	19137-01	Equalizer, Cast, Rubber Bushing, Two Bolt, 42 1/2 & 49" Axle Spacing	2
2	R3011452	-	24711-01	Equalizer, Fabricated, Rubber Bushing, One Bolt, 44" & 50" Axle Spacing,	2
	R3015480	-	24712-01	Equalizer, Fabricated, Two Hole, Rubber, Bushing for 44" & 50" Axle Spacing	2
	R309472	G-9472	-	Equalizer Bushing, Rubber & Bolt Kit, One Bolt Model	2
	R309473	-	-	Equalizer Bushing, Poly & Bolt Kit, One Bolt Model	2
3	R302003	G-2003	-	Equalizer Bushing, Rubber & Bolt Kit, Two Bolt Model	2
	R309474	-	-	Equalizer Bushing, Poly & Bolt Kit, Two Bolt Model	2
3	R304835	G-4835	10287-00	Rebound Bolt Kit; 5/8"-18 x 4 1/2" Long, Includes Bolt, Spacer, & Nut	6
4	R302907A	G-2907A	16868-01	U-Bolt Top Plate	4
	R3016389	-	9202-00	U-Bolt Top Plate, Flat for Upper Mounted U-Bolts	4
5	R302842	-	-	Delrin Spring Liner Pad	8
	R3016520	-	7052-02	Galvanized Steel Spring Liner Pad	8
6	R302909	G-2909	710-00	Bottom Plate, 5" Rd. Axle, 7/8" Dia. U-bolts	4
	R302909	G-2909	710-00	Bottom Plate, 5" Rd. Axle, 7/8" Dia. U-bolts	2
7	R3016394	-	16398-04	Adjustable Torque Arm, 18 1/2"-21", Center-to-Center, O.E., 49" & 50" Axle Spacing	2
	R303277	G-3277	16398-04	Adjustable Torque Arm, 18 1/2"-21" Center-to-Center, 49" & 50" Axle Spacing	2
	R3016395	-	715-00	Rigid Torque Arm, 19 1/4" Center-to-Center, O.E., 49" & 50" Axle Spacing	2
	R302899	-	715-00	Rigid Torque Arm, 19 1/4" Center-to-Center, 49" & 50" Axle Spacing	2
	R3011448	-	16398-06	Adjustable Torque Arm, 21 1/4"-23 3/4" Center-to-Center Rear, No Hop 5" Rd. Axle, 49" & 50" Axle Spacing	8
8	R3016390	-	16398-01	Adjustable Torque Rod; 13"-15 1/2" Center-to-Center, Front 42 1/2" & 44" Axle Spacing	8
	R303079	G-3079	-	Torque Arm Bushing, Rubber & Bolt Kit Assy Includes Bushing & Hardware	8
	R309486	-	-	Torque Arm Bushing, Poly & Bolt Kit Assy Includes Bushing & Hardware	As Required
9	R309839	-	-	Torque Arm Bolt and Flange Nut	As Required
10	R3015459	-	18541-01	Spring Rebound Bushing, Rear Hanger Mounted, Optional	As Required
-	R307682	-	7717-01	Hanger Repair Bushing Washer For Fabricated Hangers (weld in place)	-
	R309487	-	755-03	Replacement Hanger Wear Pad	-

For the complete suspension and components offering, visit MeritorPartsXpress.com or check out the PB9968 series of the Suspension catalog on Meritor.com/LOD.



Trailer, Air Ride, Tandem Axle



RHP/MPA RideSentry is an air suspension that is of the parallelogram style. The suspension features four air bags connected to a central frame by two upper control arms and four lower torque arms.

Exploded View

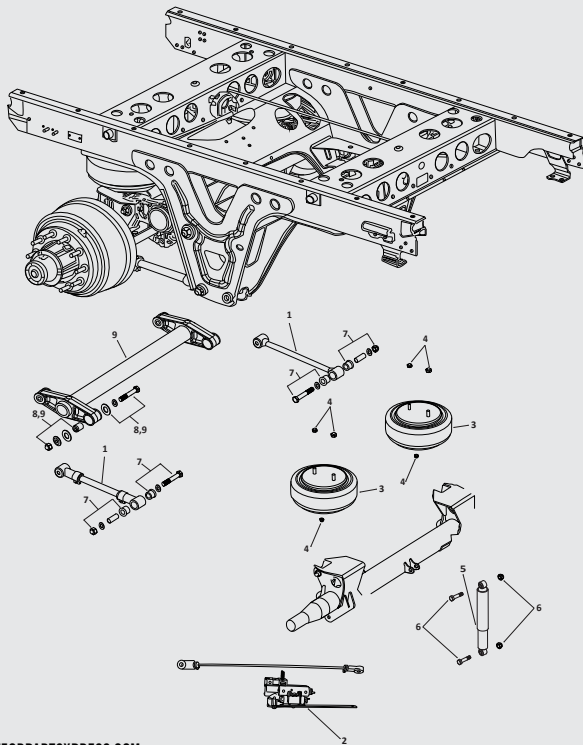

SCAN FOR VISUAL SEARCH ON [MERITORPARTSEXPRESS.COM](https://www.meritorpartsexpress.com)



TECH TIP

Loose fasteners that are allowed to operate for any period of time will result in irreversible damage. Retightening a worn fastener will not correct a situation created by loose operation. It is imperative that fastener and other affected parts including bushings be replaced.

KEY NO.	MERITOR PART NO.	OEM REF.	DESCRIPTION	QTY. PER TANDEM
1	A1-3133-Y-8345	A1-3133-Y-8345	Adjustable Torque Arm, Includes Bushing	2
	A-3133-G-8249	A-3133-G-8249	Rigid Torque Arm, Includes Bushing	2
2	KIT 11308	KIT 11308	Height Control Valve, Remove Air to Dump, Includes Linkage, RHP Only	1
	KIT 11309	KIT 11309	Height Control Valve, No Dump, Includes Linkage, RHP Only	1
	KIT 11332	KIT 11332	Height Control Valve, Remove Air to Dump, Includes Linkage, MPA Only	1
	KIT 11333	KIT 11333	Height Control Valve, No Dump, Includes Linkage, MPA Only	1
3	A-2258-F-1410	A-2258-F-1410	Air Spring, RHP11 & MPA 16.5" Ride Height	4
	A-2258-W-1531	A-2258-W-1531	Air Spring, MPA 17.5" Ride Height, Requires 1244-C-2733 Spacer	4
	A-2258-X-1532	A-2258-X-1532	Air Spring, MPA 18.5" Ride Height, Requires two 1244-C-2733 Spacers	4
4	KIT 11105	KIT 11105	Hardware Kit, Air Spring, Includes Upper & Lower Nuts	4
5	M85919	M85919	Shock Absorber	2
6	KIT 11103	KIT 11103	Bolt Kit, Shock Absorber, Includes Bolt & Nut	2
7	KIT 11102	KIT 11102	Torque Arm Bushing & Bolt Kit, Includes Bushing, Bolt, Washer, Inner Sleeve & Nut	8
8	KIT 11300	KIT 11300	Control Arm Bushing & Bolt Kit, Includes Bushing & Hardware	2
9	KIT 11305	KIT 11305	Control Arm Assembly, Includes Control Arm, Bushing & Hardware	2

For the complete suspension and components offering, visit MeritorPartsXpress.com or check out the PB9968 series of the Suspension catalog on Meritor.com/LOD.





Trailer, Air Ride, Single Axle



The CBX23/25 suspension is a trailing arm air suspension. It comes in several versions to include 23,000 lbs and 25,000 lbs top mount and underslung models. The suspension features a unique alignment system that uses a screw to perform the adjustment.

Exploded View

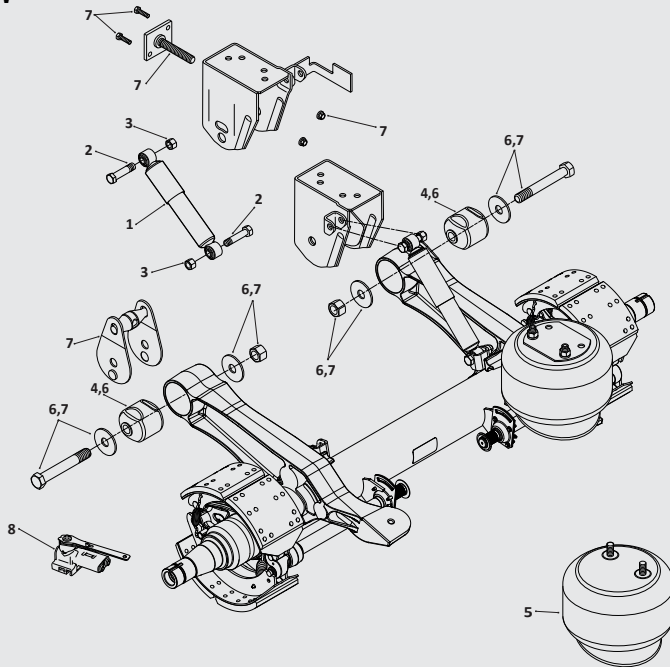

SCAN FOR VISUAL SEARCH ON MERITORPARTSEXPRESS.COM

WEAR ITEMS

Pivot bushing, air springs, shocks, Height Control Valve (HCV).



KEY NO.	MERITOR PART NO.	OEM REF.	DESCRIPTION	QTY. PER TANDEM
1	M83128	90045298	Shock Absorber, CBX23/40, 15 1/2"-16" Ride Height	2
	M83128	90044162	Shock Absorber, CBX40, 16 1/2"-17" Ride Height	2
	M85045	90044868	Shock Absorber, CBX 23, 14" Ride Height	2
	M83130	90045040	Shock Absorber, CBX40, 18" Ride Height	2
2	R304345	93006035	Bolt, 3/4"-10 x 3 1/2" Long	4
3	R304347	93400492	Nut, 3/4" -10	4
4	R3016566	90008247	Bushing, Front Pivot, Rubber	2
5	FS9807	50857000	Firestone Air Spring, CBX40	2
	FS9974	90557369	Firestone Air Spring, CBX23, 16" & 17" Ride Height	2
6	R3016552	48100394/SRK-530	Connection Kit, Pivot	1
7	R3016553	48100406/SRK-542	Swing Align Kit	1
8	R3016586	50860013	Height Control Valve, No Dump	1
	R3016571	50860016	Height Control Valve, Remove Air to Dump	1
	R3014729	H01500UN	Height Control Valve, Universal, No Dump, Hadley Next Gen Series	1
	R3014730	H01502UNC	Height Control Valve, Universal, Remove Air to Dump	1

For the complete suspension and components offering, visit MeritorPartsXpress.com or check out the PB9968 series of the Suspension catalog on Meritor.com/LOD.





Trailer, Leaf Spring, Tandem



Duralite is a leaf spring suspension used primarily on tandem axle trailers. The suspension only comes in fabricated version and is popular with line haul and dry van applications. Note the straight lines of the hanger vs. Hutch H7700/9700 which is more curved.

Exploded View

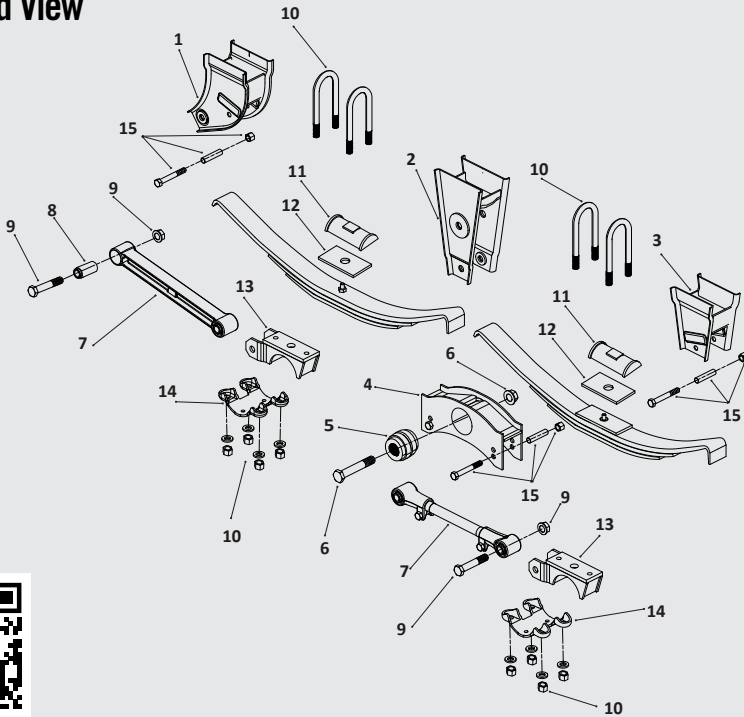

SCAN FOR VISUAL SEARCH ON MERITORPARTSEXPRESS.COM

WEAR ITEMS

Equalizers and bushings, torque arms and bushings.



KEY NO.	MERITOR PART NO.	MACH PART NO.	OEM REF.	DESCRIPTION	QTY. PER TANDEM
1	R309302	-	SP0100	Front Hanger, Straddle Mount	2
2	R309303	-	SP0110	Equalizer Hanger, Straddle Mount	2
3	R309304	-	SP0120	Rear Hanger, Straddle Mount	2
4	R309305	G-9305	SP0131	Equalizer with R304827 Bushing	2
5	R304827	G-4827	XB-SP0054-05	Equalizer Bushing	2
6	R309309	-	-	Equalizer Bolt & Nut Assembly	2
7	R304824	G-4824	SP0123	Adjustable Torque Arm with R301980 Bushings	2
	R309307	G-9307	SP0143	Rigid Torque Arm with R301980 Bushings	2
8	R301980	G-1980	XB-SP0054-02	Bushing, Torque Arm, Rubber	8
	R307520	-	-	Bushing, Torque Arm, Poly	8
9	R309308	-	-	Torque Arm Bolt & Nut Assembly	8
10	R30U8151-10	-	SP0075-01	U-Bolt, Assembly, Round Bend, 3/4"-16 x 3" Wide x 10" Long	8
	R30U8151-12	-	SP0075-02, -03, -04, -05	U-Bolt, Assembly, Round Bend, 3/4"-16 x 3" Wide x 12" Long	8
	R30U8151-14	-	SP0075-06, -07, -08	U-Bolt, Assembly, Round Bend, 3/4"-16 x 3" Wide x 14" Long	8
11	R302907A	G-2907A	SP0136	U-Bolt, Top Plate	4
12	R302842	-	SP0049	Delrin Spring Liner	4
13	R3016630	-	SP0149-05	Spring Seat, 2 3/4" high	4
14	R302909	G-2909	SP0099	Bottom Plate	4
15	R304835	G-4835	-	Rebound Bolt, Assembly	8

For the complete suspension and components offering, visit MeritorPartsXpress.com or check out the PB9968 series of the Suspension catalog on Meritor.com/LOD.





NOT RESPONSIBLE FOR
DAMAGE CAUSED BY
FOLLOWING TOO CLOSE

STA
20



DUMP TRUCKS



**CHALMERS:
800 SERIES**



**FREIGHTLINER:
TUFTRAC®**



**HENDRICKSON:
HAULMAAX®**



**HENDRICKSON:
HN®**

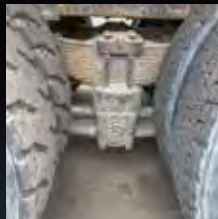

**HENDRICKSON:
RT®**



**MAK: SS44 SERIES,
CAMELBACK**



CHALMERS: 800 SERIES

Truck, Drive Axle, Tandem, Bolster Spring/Rubber Pad



Chalmers 800 Series is a bolster spring suspension with walking beams, two load springs and eight torque arms. The suspension is known for being a reliable on road and off road system with high articulation. It is common to find the Chalmers 800 on dump trucks, cement trucks and other vocational vehicles.

Exploded View

SCAN FOR VISUAL SEARCH ON MERITORPARTSEXPRESS.COM

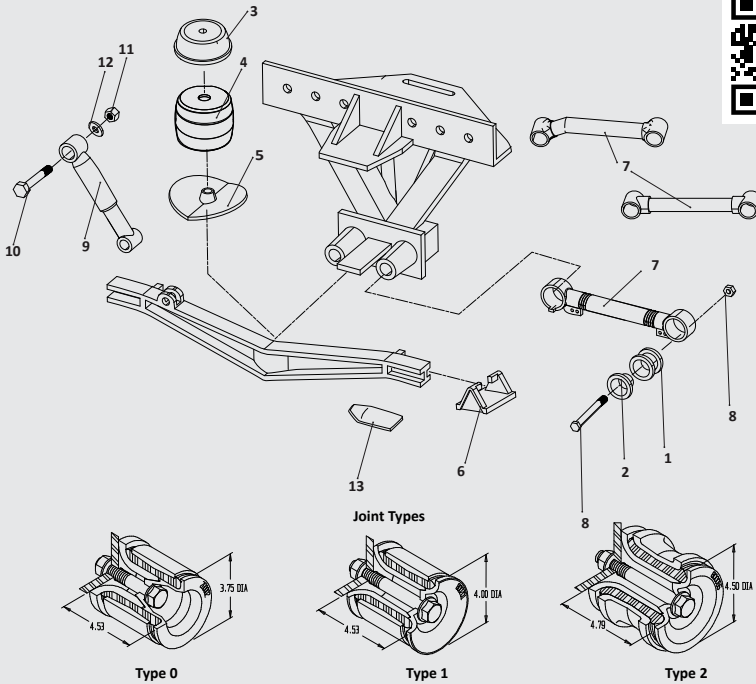

WEAR ITEMS

Torque rod/arm bushings and caps, load cushions.



TECH TIP

Change one rod at a time! Otherwise, axles will slide and make re-installation of rods very difficult.

KEY NO.	MERITOR PART NO.	MACH PART NO.	OEM REFERENCE	DESCRIPTION	QTY. PER TANDEM
1	R304677A	G-4677A	22128	Torque Arm Bushing, Rubber, Type 0 & 1 Joints	16
	R307766	G-7766	800010	Torque Arm Bushing, Rubber, Type 2 Joints	16
	R304678A	G-4678A	22129	Torque Arm Bushing, Rubber, Oversized, Type 0 & 1 Joints	As Required
	R308702	-	22129	Torque Arm Bushing, Rubber, Oversized Version, OE Equivalent	As Required
	R307767	G-7767	800009	Torque Arm Bushing, Rubber, Oversized, Type 2 Joints	As Required
2	R309571	G-9571	800201	Spigot Cap, Type 1 Joint	16
	R307768	G-7768	800055	Spigot Cap, Type 2 Joint	16
3	R304688A	-	373028, 373020	Restrictor Can #28, Replaces Restrictor Can #20, 4 7/16" High x 12 5/8" Diameter	2
	R307758	-	373029	Restrictor Can #29, 5 1/8" High x 11 1/2" Diameter, High Center of Gravity	2
4	R304685	G-4685	15002	Load Spring #20, 9 1/2" Diameter	2
5	R307769	-	800117, 800689	Spring Plate, 46-58K Low Mount For 54" Axle Spread	2
	R307770	-	800125, 800691	Spring Plate, 40-58K High Mount For 60" Axle Spread,	2
	R3014982	-	800685800119	46-58K Low Mount For 72" Axle Spread	2
6	R307756	-	222083	Saddle, Most Axles	4
7	R3014985	-	223157	Rigid Torque Arm, Upper, 15 7/8" Center-to-Center, Type 0 & 1 Joints	4
	R3014986	-	800049	Rigid Torque Arm, Upper, Curved Design 46-50K, Type 2 Joints	4
	R3014773	-	807250	Adjustable Torque Arm, 46K 21 3/4" Center-to-Center, Type 2 Joints	1
	R3014774	-	807216	Adjustable Torque Arm, 46K 25" Center-to-Center, Type 2 Joints	1
	R3014987	-	807214	Adjustable Torque Arm, 21 1/2" Center-to-Center, Type 2 Joints	1
	R3014976	-	807240	Adjustable Torque Arm, 24" Center-to-Center, Type 2 Joints	1
	R3014989	-	807220	Adjustable Torque Arm, 22" Center-to-Center, Type 2 Joints	1
	R3014978	-	805214	Rigid Torque Arm, 21 1/2" Center-to-Center, Type 2 Joints	1
	R3014990	-	805216	Rigid Torque Arm, 21 3/4" Center-to-Center, Type 2 Joints	1
	R3014991	-	805220	Rigid Torque Arm, 22" Center-to-Center, Type 2 Joints	1
8	R307773	-	K880231	Hardware Kit, Type 1 Joint	4
	R307774	-	K880460	Hardware Kit, Type 2 Joint	4
9	M85301	-	800670	Shock Absorber, High Mount	4
	M85305	-	800781	Shock Absorber, Low Mount	4
	M85060	-	665174	Shock Absorber, Standard Mount	4
10	R3014994	-	HDW372	Bolt, Shock Absorber 3/4"-10 x 5 1/2" Long	4
	R304345	-	HDW375	Bolt, Shock Absorber 3/4"-10 x 3 1/2" Long	4
11	R304347	-	HDW 018	Lock Nut, 3/4"-10 Thread	4
12	R302545	-	HDW 031	Washer, 3/4" Hardened	4
13	R307765	-	700313	Wear Plate	As Required

For the complete suspension and components offering, visit MeritorPartsXpress.com or check out the PB9968 series of the Suspension catalog on Meritor.com/LOD.



Truck, Drive Axle, Bolster Spring/Rubber Pad & Leaf Spring, Tandem, V-Rods



TufTrac is a bolster spring suspension with two bolster springs, four torque rods, two V-rods and eight insulator pads. This suspension is offered in a 40K and 46K versions for vocational applications.

Exploded View

SCAN FOR VISUAL SEARCH ON MERITORPARTSEXPRESS.COM

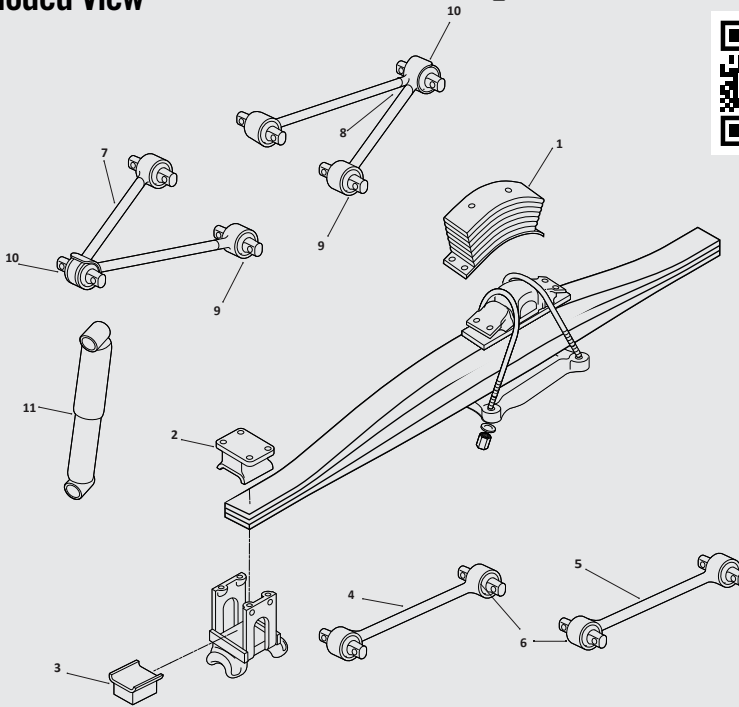

WEAR ITEMS

Torque arms and insulator caps/pads.



KEY NO.	MERITOR PART NO.	MACH PART NO.	OEM REFERENCE	DESCRIPTION	QTY PER TANDEM
1	-	G-16060	16-15010-000	Bolster Spring	2
2	-	G-16053	11-22805-000	Upper Insulator cap, 40K	4
	-	G-16051	11-19581-000	Upper Insulator cap, 46K	4
3	-	G-15588	11-20807-000	Lower Insulator Pad	4
4	R3016058	-	16-15002-000	Torque Rod, Front w/ 54" Axle Spacing	2
	R3016055	-	16-14998-000	Torque Rod, Front w/ 56" Axle Spacing	2
5	R3016059	-	16-15002-001	Torque Rod, Rear w/ 54" Axle Spacing	2
	R3016054	-	16-14998-001	Torque Rod, Rear w/ 56" Axle Spacing	2
6	R3016064	-	-	Torque Rod Bushing Kit, Includes (2) Bushings and (2) Snap Rings	4
7	R3016056	-	16-15001-000	V-Rod, Front 40K, 54" Axle Spacing	1
	R3016061	-	16-15069-000	V-Rod, Front 46-52K, 56" Axle Spacing	1
8	R3016057	-	16-15001-001	V-Rod, Rear 40K, 54" Axle Spacing	1
	R3016062	-	16-15069-001	V-Rod, Rear 46-52K, 56" Axle Spacing	1
9	R3016066	G-16066	-	V-Rod Bushing Kit, Outer Bushings, Includes (2) Bushings and (2) Snap Rings for all V-rods	4
10	R3016069	G-16069	-	V-rod center Bushing Kit, Includes (1) Bushing and (1) Snap Ring for V-Rods R3016056 & R3016057	2
	R3016070	-	-	V-rod center Bushing Kit, Includes (1) Bushing and (1) Snap Ring for V-Rods R3016061 & R3016062	2
11	M85956	-	16-15770-000	Shock Absorber	2

For the complete suspension and components offering, visit MeritorPartsXpress.com or check out the PB9968 series of the Suspension catalog on Meritor.com/L0D.





Truck, Drive Axle, Bolster Spring/Rubber Pad, Tandem, Transverse Torque Arm



The HAULMAAX is the latest Hendrickson bolster spring suspension that features eight bolster springs, four per side, connected to a walking beam. Like the HN it removes the need for a center bushing for the beam to pivot on. In addition to the bolster springs the HAULMAAX is fitted with a progressive load spring designed to improve ride quality. This is a very popular vocational suspension especially on refuse and dump applications and also features the standard Hendrickson four end beam bushings.

Exploded View

SCAN FOR VISUAL SEARCH ON MERITORPARTSXPRESS.COM

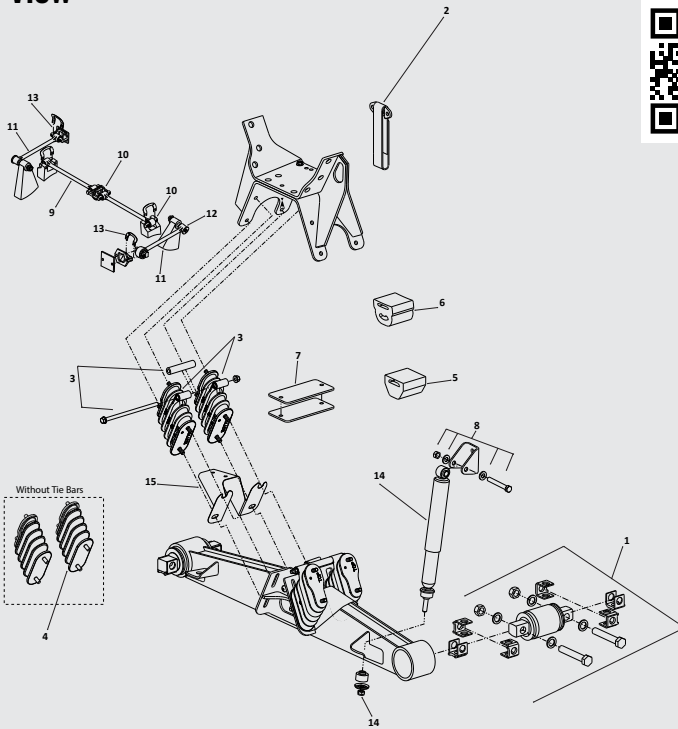

WEAR ITEMS

Bolster spring, aux load spring, end beam bushings.



TECH TIP

The HAULMAXX suspension must be equipped with at least one load spring shim on each side, failure to do so can cause premature component wear, equalizing beam misalignment.

KEY NO.	MERITOR PART NO.	OEM REFERENCE	DESCRIPTION	QTY. PER TANDEM
1	R309326	34013-088	Bar Pin Bushing Kit, Shim Type	4
	R3014725	34013-188	Bar Pin Bushing Kit, Rotating Bushing, Shim Type	4
2	R3013986	57878-003	Rebound Strap	2
-	R3015168	64179-028	Rebound Strap Service Kit, Includes Hardware and Clip	As Required
3	R3014807	64179-048	Tie-Bar Bolster Spring Service Kit, Includes Wear Plate	4
4	R3016356	64179-049	Bolster Spring w/o Tie-Bar Service Kit, Includes Wear Plate	4
5	R3014047	60314-000	Auxiliary Load Spring For Vehicles Built Before 07/15/14	4
	R3014534	64179-004	Auxiliary Spring Service Kit For Vehicles Built Before 07/15/14, Includes Hardware	2
6	R3014896	67778-000	Progressive Load Spring For Vehicles Built After 07/15/14	4
	R3016357	60961-747	Progressive Load Spring Service Kit For Vehicles Built After 07/15/14, Includes Hardware	1
7	R3015155	60791-000	Auxiliary Spring Shim - 0.25"	6
8	R305277	49176-001	Bolt Assembly 5/8"-18 x 4 1/2" Long, Includes Bolt, Nut, Washers	4
9	See Torque Rod Section Page 88	Various	Ultra Rod Longitudinal Torque Rod Straddle/Straddle Assembly	2
10	R305275	47691-000	Ultra Rod Straddle Bushing	4
11	See Torque Rod Section Page 88	62350-000	Ultra Rod Transverse Torque Rod Straddle/Taper Assembly	2
12	R3010309	64697-000H	Ultra Rod Taper Bushing	2
13	R305281	49689-000	Torque Rod Shim	As Required
14	M83143	60680-004	Shock Absorber Assembly, 16 1/2" Saddle Ht.	4
	M83142	60680-005	Shock Absorber Assembly, 17 1/2" & 18 1/2" Saddle Ht.	4
15	R3014535	64890-000	Wear Plate, Also Included in Bolster Spring Service Kit, Key No. 3 and 4	2

For the complete suspension and components offering, visit MeritorPartsXpress.com or check out the PB9968 series of the Suspension catalog on Meritor.com/LOD.



Truck, Drive Axle, Bolster Spring/Rubber Pad, Tandem, Transverse Torque Arm



The HN is a bolster spring suspension with four bolster springs, two per side, connected to a walking beam. The design removes the need for a center bushing that a walking beam normally pivots on. This suspension is common on vocational vehicles that travel on and off the road. This uses the standard Hendrickson four end beam bushings.

Exploded View

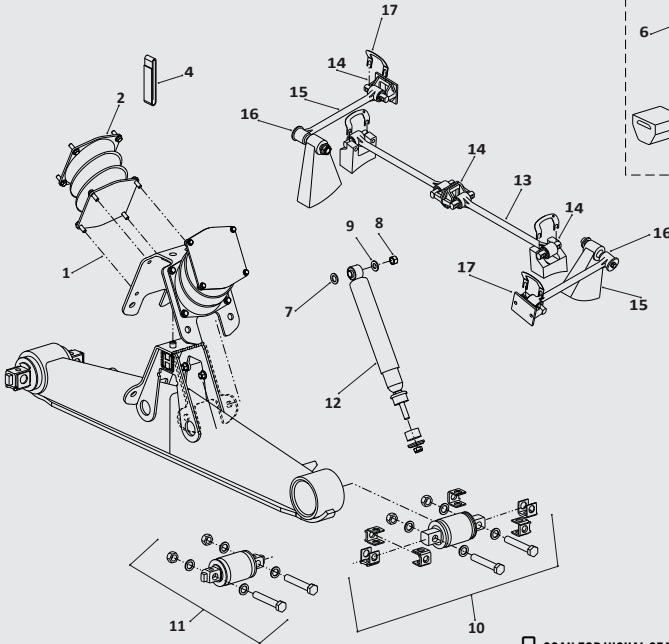

Auxiliary Load Spring
After 11/00

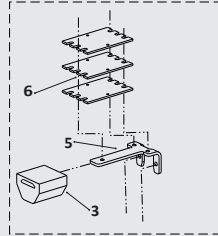

SCAN FOR VISUAL SEARCH ON MERITORPARTSEXPRESS.COM

WEAR ITEMS

Bolster spring, aux load spring, end beam bushings.



TECH TIP

If Bar Pin movement or looseness is noticed in the beam end, hub replace the bushings and connecting hardware immediately. Failure to do so can result in costly repairs down the road and an unsafe vehicle.

KEY NO.	MERITOR PART NO.	OEM REFERENCE	DESCRIPTION	QTY. PER TANDEM
1	R3016398	-	Bolster Spring Fastener Kit For One Bolster Spring, Includes Bolt, Nut and Washer	4
2	R3011496	60879-000	Bolster Spring Service Kit, 1 Pair for 1 Side (Must be replaced in pairs)	2
3	R3014047	60314-000	Auxiliary Load Spring, 3 3/8" High	-
4	R3013986	57878-003	Rebound Strap	2
5	R3015171	58948-001	Auxiliary Load Spring Mounting Plate - 1/4" thick	-
6	R3015173	58960-003	Auxiliary Spring Mounting Shim	-
7	R302545	22962-001	Washer, 3/4"	4
8	R301943	30585-000	Locknut, 5/8"-18	4
9	R302547	22962-004	Washer, 5/8"	4
10	R309326	34013-088	Bar Pin Bushing Service Kit, Shim Type (Includes mounting hrdw & shims)	4
11	R309325	34013-087	Bar Pin Bushing Service Kit, Non-Shim Type (Includes Mounting Hrdw)	4
12	M83112	60680-003	Shock Absorber	4
13	R3013989	60218-000	Torque Rod Kit, ULTRA ROD, Two Straddle Mount Bushing, 27" Max Length	2
14	R305275	47691-000	ULTRA ROD Straddle Bushing	2
15	R3013988	60215-000	Transverse Torque Rod Kit, ULTRA ROD, Staddle and Tapered Bushings	2
16	R3010309	64697-000	ULTRA ROD Tapered Bushing	-
17	R305281	49689-000	Torque Rod Shim	As Required

For the complete suspension and components offering, visit MeritorPartsXpress.com or check out the PB9968 series of the Suspension catalog on Meritor.com/LOD.



Truck, Drive Axle, Leaf Spring, Tandem, Transverse Torque Arm for High Capacities



The RT is a steel spring suspension that features a walking beam with a center bushing used as a pivot point. This suspension has been in service for over 90 years and is known for its reliability. This system is used on vocational applications, requires transverse torque rods for high capacity applications. This system also features the standard Hendrickson four end beam bushings. Older walking beams are cast and newer versions are fabricated.

Exploded View

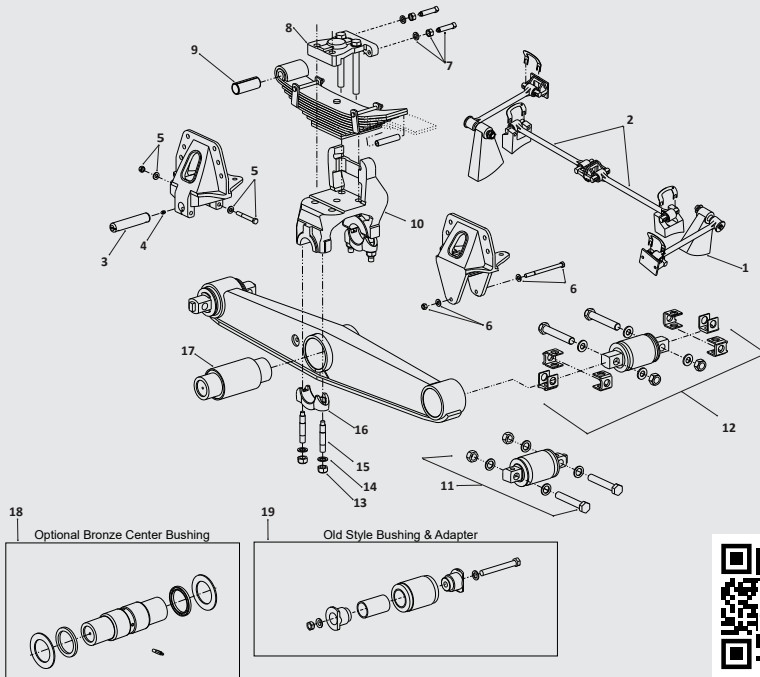

SCAN FOR VISUAL SEARCH ON MERITORPARTSXPRESS.COM

WEAR ITEMS

Center and end beam bushings.



TECH TIP

Look for loose or damaged fasteners on the entire suspension. Ensure that all fasteners are torqued to correct specifications. If loose fastener discovered inspect all mating parts closely. It is also recommended the replacement of springs be done in pairs to keep equal spring deflection on both sides.

KEY NO.	MERITOR PART NO.	OEM REFERENCE	DESCRIPTION	QTY. PER TANDEM				
				RT/RT 340	RT/RT 400	RT/RT 460	RT/RT 480	RT/RT 520
1	R3013988	60215-000	Two-Piece Transverse Torque Rod Kit, Includes Straddle Bushings	2	2	2	2	2
2	See Torque Rod Section Page 88	Various	Longitudinal Torque Rod Assembly	2	2	2	2	2
3	R301818	32277-000	Spring Pin, Single Lock Pin/Groove	2	2	-	-	-
	R303761	43146-000	Spring Pin, Double Lock Pin/Groove	2	2	2	2	2
4	R301307	33117-000	Lube Fitting	2	2	2	2	2
5	R309427	29828-035	Lock Bolt Kit	2	2	2	2	2
6	R309428	29828-023	Rebound Bolt & Spacer Assembly	2	2	2	2	2
7	R309429	35370-002	Set Screw Kit	4	4	4	4	4
8	R301869	35064-000	Top Pad	2	2	2	2	2
9	R301877	30057-008	Spring Eye Bushing 1 3/8" I.D.	2	2	2	2	2
10	R301853	31017-022	Saddle Assembly, 6" Height	2	2	-	-	-
	R301854	31017-096	Saddle Assembly, 6" Height	-	-	2	-	-
	R307531	31017-053	Saddle Assembly, 6" Height	-	-	-	2	2
11	R309325	34013-087	Bar Pin Bushing Kit, Non-Shim Type	4	4	4	4	4
12	R309326	34013-088	Bar Pin Bushing Kit, Shim Type	4	4	4	4	4
	R3014725	34013-188	Bar Pin Bushing Kit, Free Rotating Bushing, Shim Type	4	4	4	4	4
13	R301835	04842-000	Nut, Saddle Cap Stud	8	8	8	8	8
14	R301834	22962-002	7/8" Hardened Washer	8	8	8	8	8
15	R301830	06696-000	7/8"-14 Saddle Cap Stud	-	8	8	8	8
	R301829	07002-000	7/8"-14 Saddle Cap Stud	8	-	-	-	-
16	R301833A	58795-000	Saddle Cap	-	4	4	4	4
	R3016464	06662-000	Saddle Cap	4	-	-	-	-
17	R301338	06664-000	Rubber Center Bushing with Welded End Plug	2	-	-	-	-
	R301594	22279-000	Rubber Center Bushing with Loose End Plug	2	-	-	-	-
	R306979	49400-000	Rubber Center Bushing with Welded End Plug	2	2	-	-	-
	R306980	49600-000	Rubber Center Bushing with Loose End Plug	2	2	-	-	-
	R309359	29483-005	Rubber Center Bushing with Welded End Plug	-	-	2	2	2
	R3016416	34013-097	Rubber Center Bushing with Loose End Plug	-	-	2	2	2
18	R301546	30437-000	Kit, Bronze Center Bushings, Includes Thrust Washer, Seal, Sleeve, and Bronze Bushing	1	1	1	1	1
19	R305309	34013-049	End Beam Bushing Kit, Old Style, Includes Bushing and Adapter	4	4	-	-	-
	R309576	34013-073	End Beam Bushing Kit, Old Style, Includes Bushing and Adapter	-	-	4	-	-
	R309577	34013-050	End Beam Bushing Kit, Old Style, 5 3/4" Long Bushing, Includes Bushing and Adapter	-	-	-	4	4

For the complete suspension and components offering, visit MeritorPartsXpress.com or check out the PB9968 series of the Suspension catalog on Meritor.com/LOD.



MACK: SS44 SERIES, CAMELBACK

Truck, Drive Axle, Single Point Leaf Spring, Tandem Axles



Mack Camelback is a single point spring suspension that pivots on a trunnion bushing. The suspension has a unique hump in the spring stack that lends to its name. It is easily identifiable and comes in a variety of capacities. The most common version is the SS44 series that uses 4" wide springs and a trunnion bushing with a 3 1/2" ID. This suspension has been around for decades and has a proven track record for reliability. It is commonly found on vocational trucks and especially on dump trucks.

Exploded View

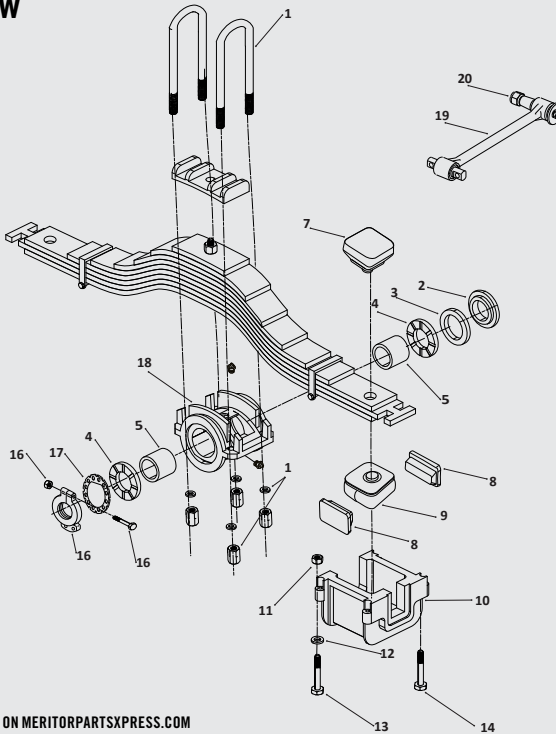

SCAN FOR VISUAL SEARCH ON MERITORPARTSEXPRESS.COM

WEAR ITEMS

Rubber insulator pads and trunnion bushings.



KEY NO.	MERITOR PART NO.	MACH PART NO.	OEM REFERENCE	DESCRIPTION	QTY PER TANDEM
1	R30U8394-144	-	-	U-Bolt Assembly, Semi Rd. Bend, 1 1/4"-12 x 4" Wide x 14-1/2" Long	4
	R30U8394-162S	-	-	U-Bolt Assembly, Semi Rd. Bend, 1 1/4"-12 x 4" Wide x 16-1/4" Long	4
	R30U8394-18	-	-	U-Bolt Assembly, Semi Rd. Bend, 1 1/4"-12 x 4" Wide x 18" Long	4
2	R303187	-	88AX244; 88AX446	Trunnion Seal, 5 1/2" OD x 4 3/8" ID x 9/16" Thick	2
3	R303699	-	43QK117	Steel Washer, 5 3/8" OD x 4 3/8" ID x 3/8" Thick	2
4	R303698	-	35AX688; 43QK116	Bronze Thrust Washer, 5 5/16" OD x 3 1/2" ID x 1/4" Thick	2
5	R302925	-	10QK157; 80AX300	Bronze Trunnion Bushing, 3 3/4" OD x 3 1/2" ID x 3 7/16" Long	4
6	R303916	G-3916	-	Trunnion Rebuild Kit, Includes Key No. 2, 3, 4, 5, 17, 18. Axle Set	1
7	R302918	-	10QK33A	Upper Insulator Pad, Rubber, 6" Long x 4 1/2" Wide x 3" Thick, 1 1/4" Dia. Pin	4
	R307642	-	-	Upper Insulator Pad, Poly, 6" Long x 4 1/2" Wide x 3" Thick, 1 1/4" Dia. Pin	4
	R302919	-	10QK370	Upper Insulator Pad, Rubber, 6" Long x 4 1/2" Wide x 3" Thick, 1 3/4" Dia. Pin	4
	R308667	-	-	Upper Insulator Pad, Poly, 6" Long x 4 1/2" Wide x 3" Thick, 1 3/4" Dia. Pin	4
8	R303689	-	13QK246	Insulator Spacer Block	8
9	R302920	-	10QK36B	Lower Insulator Pad, Rubber, 6" Long x 6" Wide x 3 3/4" Thick, 1 3/4" Dia. Pin	4
	R307480	-	-	Lower Insulator Pad, Poly, 6" Long x 6" Wide x 3 3/4" Thick, 1 3/4" Dia. Pin	4
10	R303688	-	52QK418BP4	Insulator Box, 6 3/4" Deep	2
	-	G-16782	52QK418BP5	Insulator Box, 6 3/8" Deep	2
11	R301835	-	21AX480	Lock Nut, 7/8"-14	8
12	R302546	-	37AX1310	Washer, 7/8" ID	8
13	R303690	-	1AX425	Insulator Box Bolt, 7/8"-14 x 5" Long	8
	R303691	-	1AX475	Insulator Box Bolt, 7/8"-14 x 5 1/4" Long	8
	R303692	-	1AX427; 3AX987	Insulator Box Bolt, 7/8"-14 x 6" Long	8
	R303693	-	3AX1344	Insulator Box Bolt, 7/8"-14 x 6 1/2" Long	8
	R305439	-	3AX1050	Insulator Box Bolt, 7/8 "-14 x 7 1/2 " Long	8
	R305428	-	3AX1348	Insulator Box Bolt, 7/8 "-14 x 8 " Long	8
14	R303696	-	4AX320; 6AX837	Insulator Box Stud, 7/8"-9 x 4 1/2" Long	8
	R305427	-	6AX1160	Insulator Box Stud, 7/8"-9 x 6" Long	8
15	R303697	G-3697	97QL399P2	Trunnion Grease Cap, 5/16" Dia. Bolt Holes, 7" Bolt Circle	2
16	-	G-16787	-	Trunnion Nut & Hardware, Includes Trunnion Nut	2
17	R303915	-	23QJ112B	Star Lock Washer, 4 7/8" OD x 1/4" Thick	2
18	R303687	-	39QK27E; 39QK27F; 39QK326	Trunnion and Bushing Assembly	2
19	R303988	-	-	Transverse Torque Arm Kit, Full Ball Design	1
20	R302815	-	46735	Torque Arm Bushing, Tapered Stud	2

For the complete suspension and components offering, visit MeritorPartsXpress.com or check out the PB9968 series of the Suspension catalog on Meritor.com/LOD.





REFUSE TRUCKS



**FREIGHTLINER:
TUFTRAC®**



**HENDRICKSON:
HAULMAAX®**



**HENDRICKSON:
HN®**



**MACK: SS44 SERIES,
CAMELBACK**



Truck, Drive Axle, Bolster Spring/Rubber Pad & Leaf Spring, Tandem, V-Rods



TufTrac is a bolster spring suspension with two bolster springs, four torque rods, two V-rods and eight insulator pads. This suspension is offered in a 40K and 46K versions for vocational applications.

Exploded View

SCAN FOR VISUAL SEARCH ON MERITORPARTSEXPRESS.COM

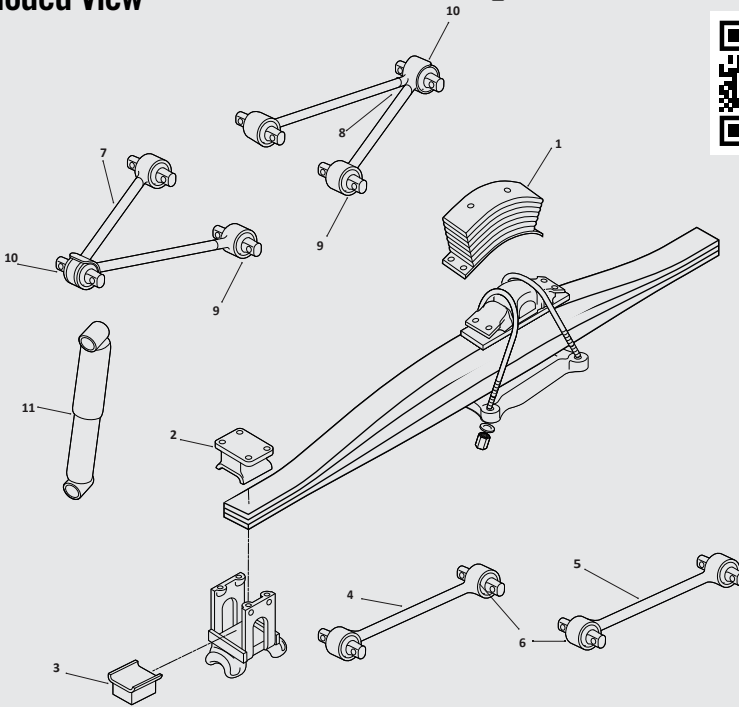

WEAR ITEMS

Torque arms and insulator caps/pads.



KEY NO.	MERITOR PART NO.	MACH PART NO.	OEM REFERENCE	DESCRIPTION	QTY PER TANDEM
1	-	G-16060	16-15010-000	Bolster Spring	2
2	-	G-16053	11-22805-000	Upper Insulator cap, 40K	4
	-	G-16051	11-19581-000	Upper Insulator cap, 46K	4
3	-	G-15588	11-20807-000	Lower Insulator Pad	4
4	R3016058	-	16-15002-000	Torque Rod, Front w/ 54" Axle Spacing	2
	R3016055	-	16-14998-000	Torque Rod, Front w/ 56" Axle Spacing	2
5	R3016059	-	16-15002-001	Torque Rod, Rear w/ 54" Axle Spacing	2
	R3016054	-	16-14998-001	Torque Rod, Rear w/ 56" Axle Spacing	2
6	R3016064	-	-	Torque Rod Bushing Kit, Includes (2) Bushings and (2) Snap Rings	4
7	R3016056	-	16-15001-000	V-Rod, Front 40K, 54" Axle Spacing	1
	R3016061	-	16-15069-000	V-Rod, Front 46-52K, 56" Axle Spacing	1
8	R3016057	-	16-15001-001	V-Rod, Rear 40K, 54" Axle Spacing	1
	R3016062	-	16-15069-001	V-Rod, Rear 46-52K, 56" Axle Spacing	1
9	R3016066	G-16066	-	V-Rod Bushing Kit, Outer Bushings, Includes (2) Bushings and (2) Snap Rings for all V-rods	4
10	R3016069	G-16069	-	V-rod center Bushing Kit, Includes (1) Bushing and (1) Snap Ring for V-Rods R3016056 & R3016057	2
	R3016070	-	-	V-rod center Bushing Kit, Includes (1) Bushing and (1) Snap Ring for V-Rods R3016061 & R3016062	2
11	M85956	-	16-15770-000	Shock Absorber	2

For the complete suspension and components offering, visit MeritorPartsXpress.com or check out the PB9968 series of the Suspension catalog on Meritor.com/LOD.





Truck, Drive Axle, Bolster Spring/Rubber Pad, Tandem, Transverse Torque Arm



The HAULMAAX is the latest Hendrickson bolster spring suspension that features eight bolster springs, four per side, connected to a walking beam. Like the HN it removes the need for a center bushing for the beam to pivot on. In addition to the bolster springs the HAULMAAX is fitted with a progressive load spring designed to improve ride quality. This is a very popular vocational suspension especially on refuse and dump applications and also features the standard Hendrickson four end beam bushings.

Exploded View

SCAN FOR VISUAL SEARCH ON MERITORPARTSXPRESS.COM

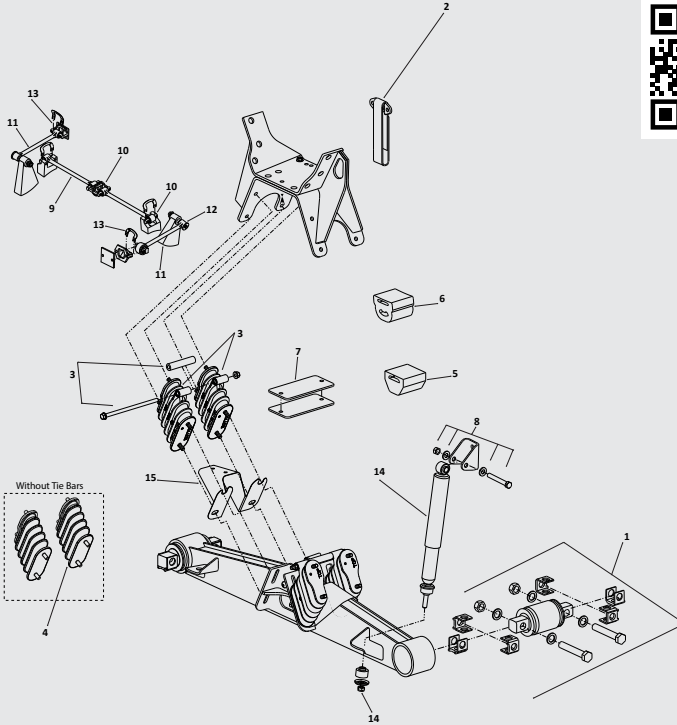

WEAR ITEMS

Bolster spring, aux load spring, end beam bushings.



TECH TIP

The HAULMAXX suspension must be equipped with at least one load spring shim on each side, failure to do so can cause premature component wear, equalizing beam misalignment.

KEY NO.	MERITOR PART NO.	DEM REFERENCE	DESCRIPTION	QTY. PER TANDEM
1	R309326	34013-088	Bar Pin Bushing Kit, Shim Type	4
	R3014725	34013-188	Bar Pin Bushing Kit, Rotating Bushing, Shim Type	4
2	R3013986	57878-003	Rebound Strap	2
-	R3015168	64179-028	Rebound Strap Service Kit, Includes Hardware and Clip	As Required
3	R3014807	64179-048	Tie-Bar Bolster Spring Service Kit, Includes Wear Plate	4
4	R3016356	64179-049	Bolster Spring w/o Tie-Bar Service Kit, Includes Wear Plate	4
5	R3014047	60314-000	Auxiliary Load Spring For Vehicles Built Before 07/15/14	4
	R3014534	64179-004	Auxiliary Spring Service Kit For Vehicles Built Before 07/15/14, Includes Hardware	2
6	R3014896	67778-000	Progressive Load Spring For Vehicles Built After 07/15/14	4
	R3016357	60961-747	Progressive Load Spring Service Kit For Vehicles Built After 07/15/14, Includes Hardware	1
7	R3015155	60791-000	Auxiliary Spring Shim - 0.25"	6
8	R305277	49176-001	Bolt Assembly 5/8"-18 x 4 1/2" Long, Includes Bolt, Nut, Washers	4
9	See Torque Rod Section Page 88	Various	Ultra Rod Longitudinal Torque Rod Straddle/Straddle Assembly	2
10	R305275	47691-000	Ultra Rod Straddle Bushing	4
11	See Torque Rod Section Page 88	62350-000	Ultra Rod Transverse Torque Rod Straddle/Taper Assembly	2
12	R3010309	64697-000H	Ultra Rod Taper Bushing	2
13	R305281	49689-000	Torque Rod Shim	As Required
14	M83143	60680-004	Shock Absorber Assembly, 16 1/2" Saddle Ht.	4
	M83142	60680-005	Shock Absorber Assembly, 17 1/2" & 18 1/2" Saddle Ht.	4
15	R3014535	64890-000	Wear Plate, Also Included in Bolster Spring Service Kit, Key No. 3 and 4	2

For the complete suspension and components offering, visit MeritorPartsXpress.com or check out the PB9968 series of the Suspension catalog on Meritor.com/LOD.



Truck, Drive Axle, Bolster Spring/Rubber Pad, Tandem, Requires Transverse Torque Arm



The HN is a bolster spring suspension with four bolster springs, two per side, connected to a walking beam. The design removes the need for a center bushing that a walking beam normally pivots on. This suspension is common on vocational vehicles that travel on and off the road. This uses the standard Hendrickson four end beam bushings.

Exploded View

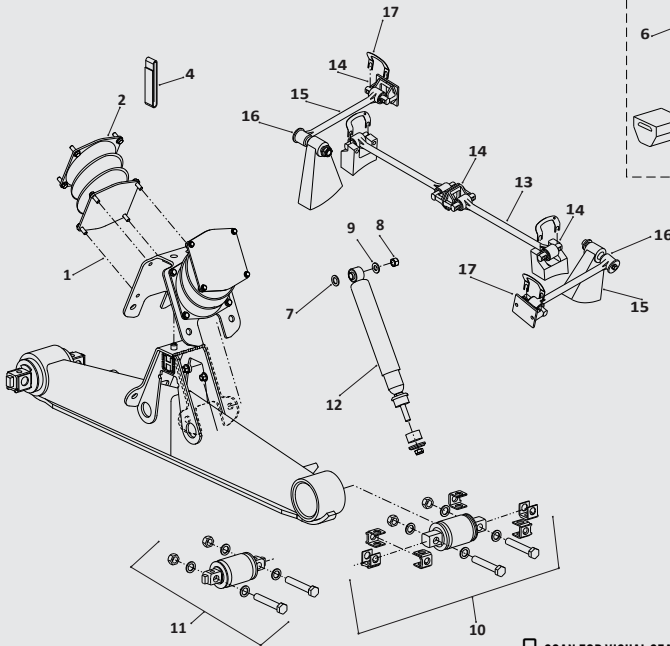

Auxiliary Load Spring
After 11/00

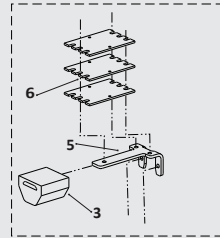

SCAN FOR VISUAL SEARCH ON MERITORPARTSEXPRESS.COM

WEAR ITEMS

Bolster spring, aux load spring, end beam bushings



TECH TIP

If Bar Pin movement or looseness is noticed in the beam end, hub replace the bushings and connecting hardware immediately. Failure to do so can result in costly repairs down the road and an unsafe vehicle.

KEY NO.	MERITOR PART NO.	OEM REFERENCE	DESCRIPTION	QTY. PER TANDEM
1	R3016398	-	Bolster Spring Fastener Kit For One Bolster Spring, Includes Bolt, Nut and Washer	4
2	R3011496	60879-000	Bolster Spring Service Kit, 1 Pair for 1 Side (Must be replaced in pairs)	2
3	R3014047	60314-000	Auxiliary Load Spring, 3 3/8" High	-
4	R3013986	57878-003	Rebound Strap	2
5	R3015171	58948-001	Auxiliary Load Spring Mounting Plate - 1/4" thick	-
6	R3015173	58960-003	Auxiliary Spring Mounting Shim	-
7	R302545	22962-001	Washer, 3/4"	4
8	R301943	30585-000	Locknut, 5/8"-18	4
9	R302547	22962-004	Washer, 5/8"	4
10	R309326	34013-088	Bar Pin Bushing Service Kit, Shim Type (Includes mounting hrdw & shims)	4
11	R309325	34013-087	Bar Pin Bushing Service Kit, Non-Shim Type (Includes Mounting Hrdw)	4
12	M83112	60680-003	Shock Absorber	4
13	R3013989	60218-000	Torque Rod Kit, ULTRA ROD, Two Straddle Mount Bushing, 27" Max Length	2
14	R305275	47691-000	ULTRA ROD Straddle Bushing	2
15	R3013988	60215-000	Transverse Torque Rod Kit, ULTRA ROD, Staddle and Tapered Bushings	2
16	R3010309	64697-000	ULTRA ROD Tapered Bushing	-
17	R305281	49689-000	Torque Rod Shim	As Required

For the complete suspension and components offering, visit MeritorPartsXpress.com or check out the PB9968 series of the Suspension catalog on Meritor.com/LOD.



MACK: SS44 SERIES, CAMELBACK

Truck, Drive Axle, Single Point Leaf Spring, Tandem Axles



Mack Camelback is a single point spring suspension that pivots on a trunnion bushing. The suspension has a unique hump in the spring stack that lends to its name. It is easily identifiable and comes in a variety of capacities. The most common version is the SS44 series that uses 4" wide springs and a trunnion bushing with a 3 1/2" ID. This suspension has been around for decades and has a proven track record for reliability. It is commonly found on vocational trucks and especially on dump trucks.

Exploded View

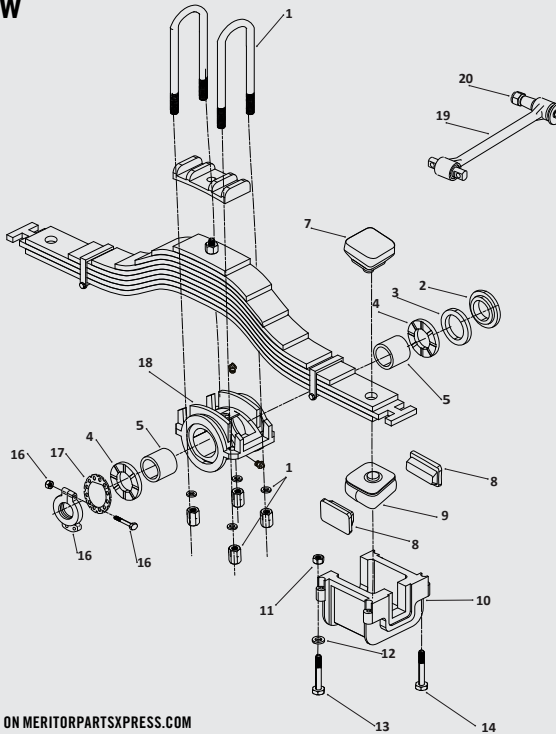

SCAN FOR VISUAL SEARCH ON MERITORPARTSEXPRESS.COM

WEAR ITEMS

Rubber insulator pads and trunnion bushings.



KEY NO.	MERITOR PART NO.	MACH PART NO.	OEM REFERENCE	DESCRIPTION	QTY PER TANDEM
1	R30U8394-144	-	-	U-Bolt Assembly, Semi Rd. Bend, 1 1/4" -12 x 4" Wide x 14 1/2" Long	4
	R30U8394-162S	-	-	U-Bolt Assembly, Semi Rd. Bend, 1 1/4" -12 x 4" Wide x 16 1/4" Long	4
	R30U8394-18	-	-	U-Bolt Assembly, Semi Rd. Bend, 1 1/4" -12 x 4" Wide x 18" Long	4
2	R303187	-	88AX244; 88AX446	Trunnion Seal, 5 1/2" OD x 4 3/8" ID x 9/16" Thick	2
3	R303699	-	43QK117	Steel Washer, 5 3/8" OD x 4 3/8" ID x 3/8" Thick	2
4	R303698	-	35AX688; 43QK116	Bronze Thrust Washer, 5 5/16" OD x 3 1/2" ID x 1/4" Thick	2
5	R302925	-	10QK157; 80AX300	Bronze Trunnion Bushing, 3 3/4" OD x 3 1/2" ID x 3 7/16" Long	4
6	R303916	G-3916	-	Trunnion Rebuild Kit, Includes Key No. 2, 3, 4, 5, 17, 18. Axle Set	1
7	R302918	-	10QK33A	Upper Insulator Pad, Rubber, 6" Long x 4 1/2" Wide x 3" Thick, 1 1/4" Dia. Pin	4
	R307642	-	-	Upper Insulator Pad, Poly, 6" Long x 4 1/2" Wide x 3" Thick, 1 1/4" Dia. Pin	4
	R302919	-	10QK370	Upper Insulator Pad, Rubber, 6" Long x 4 1/2" Wide x 3" Thick, 1 3/4" Dia. Pin	4
	R308667	-	-	Upper Insulator Pad, Poly, 6" Long x 4 1/2" Wide x 3" Thick, 1 3/4" Dia. Pin	4
8	R303689	-	13QK246	Insulator Spacer Block	8
9	R302920	-	10QK36B	Lower Insulator Pad, Rubber, 6" Long x 6" Wide x 3 3/4" Thick, 1 3/4" Dia. Pin	4
	R307480	-	-	Lower Insulator Pad, Poly, 6" Long x 6" Wide x 3 3/4" Thick, 1 3/4" Dia. Pin	4
10	R303688	-	52QK418BP4	Insulator Box, 6 3/4" Deep	2
	-	G-16782	52QK418BP5	Insulator Box, 6 3/8" Deep	2
11	R301835	-	21AX480	Lock Nut, 7/8"-14	8
12	R302546	-	37AX1310	Washer, 7/8" ID	8
13	R303690	-	1AX425	Insulator Box Bolt, 7/8"-14 x 5" Long	8
	R303691	-	1AX475	Insulator Box Bolt, 7/8"-14 x 5 1/4" Long	8
	R303692	-	1AX427; 3AX987	Insulator Box Bolt, 7/8"-14 x 6" Long	8
	R303693	-	3AX1344	Insulator Box Bolt, 7/8"-14 x 6 1/2" Long	8
	R305439	-	3AX1050	Insulator Box Bolt, 7/8"-14 x 7 1/2" Long	8
	R305428	-	3AX1348	Insulator Box Bolt, 7/8"-14 x 8" Long	8
14	R303696	-	4AX320; 6AX837	Insulator Box Stud, 7/8"-9 x 4 1/2" Long	8
	R305427	-	6AX1160	Insulator Box Stud, 7/8"-9 x 6" Long	8
15	R303697	G-3697	97QL399P2	Trunnion Grease Cap, 5/16" Dia. Bolt Holes, 7" Bolt Circle	2
16	-	G-16787	-	Trunnion Nut & Hardware, Includes Trunnion Nut	2
17	R303915	-	23QJ112B	Star Lock Washer, 4 7/8" OD x 1/4" Thick	2
18	R303687	-	39QK27E; 39QK27F; 39QK326	Trunnion and Bushing Assembly	2
19	R303988	-	-	Transverse Torque Arm Kit, Full Ball Design	1
20	R302815	-	46735	Torque Arm Bushing, Tapered Stud	2

For the complete suspension and components offering, visit MeritorPartsXpress.com or check out the PB9968 series of the Suspension catalog on Meritor.com/LOD.





CONCRETE TRUCKS



**CHALMERS:
800 SERIES**



**HENDRICKSON:
PRIMAAX®**



**HENDRICKSON:
RS®**



**SAF HOLLAND:
AD-123 (NEWAY)**



CHALMERS: 800 SERIES

Truck, Drive Axle, Tandem, Bolster Spring/Rubber Pad



Chalmers 800 Series is a bolster spring suspension with walking beams, two load springs and eight torque arms. The suspension is known for being a reliable on road and off road system with high articulation. It is common to find the Chalmers 800 on dump trucks, cement trucks and other vocational vehicles.

Exploded View

SCAN FOR VISUAL SEARCH ON MERITORPARTSEXPRESS.COM

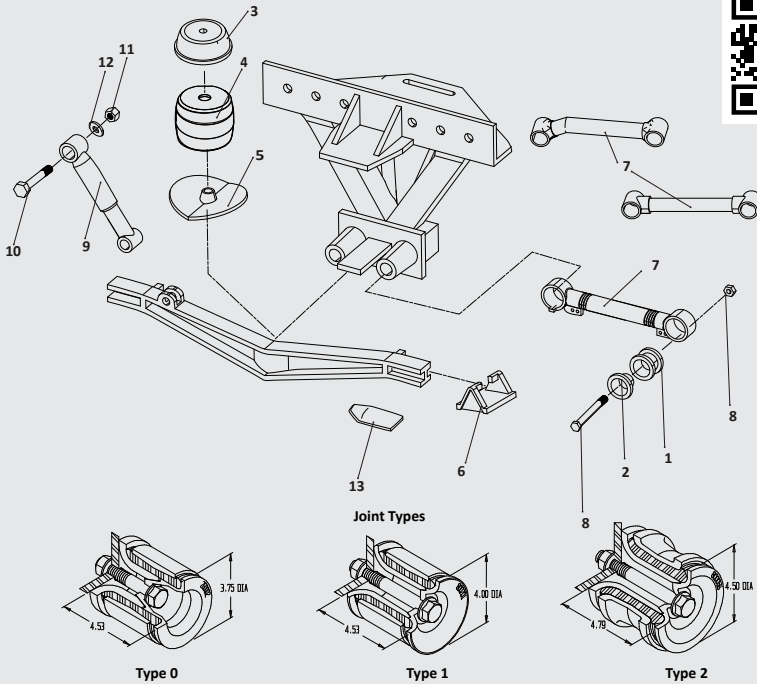

WEAR ITEMS

Torque rod/arm bushings and caps, load cushions.



TECH TIP

Change one rod at a time! Otherwise, axles will slide and make re-installation of rods very difficult.

KEY NO.	MERITOR PART NO.	MACH PART NO.	OEM REFERENCE	DESCRIPTION	QTY. PER TANDEM
1	R304677A	G-4677A	22128	Torque Arm Bushing, Rubber, Type 0 & 1 Joints	16
	R307766	G-7766	800010	Torque Arm Bushing, Rubber, Type 2 Joints	16
	R304678A	G-4678A	22129	Torque Arm Bushing, Rubber, Oversized, Type 0 & 1 Joints	As Required
	R308702	-	22129	Torque Arm Bushing, Rubber, Oversized Version, OE Equivalent	As Required
	R307767	G-7767	800009	Torque Arm Bushing, Rubber, Oversized, Type 2 Joints	As Required
2	R309571	G-9571	800201	Spigot Cap, Type 1 Joint	16
	R307768	G-7768	800055	Spigot Cap, Type 2 Joint	16
3	R304688A	-	373028, 373020	Restrictor Can #28, Replaces Restrictor Can #20, 4 7/16" High X 12 5/8" Diameter	2
	R307758	-	373029	Restrictor Can #29, 5 1/8" High X 11 1/2" Diameter, High Center of Gravity	2
4	R304685	G-4685	15002	Load Spring #20, 9 1/2" Diameter	2
5	R307769	-	800117, 800689	Spring Plate, 46-58K Low Mount For 54" Axle Spread	2
	R307770	-	800125, 800691	Spring Plate, 40-58K High Mount For 60" Axle Spread,	2
	R3014982	-	800685800119	46-58K Low Mount For 72" Axle Spread	2
6	R307756	-	222083	Saddle, Most Axles	4
7	R3014985	-	223157	Rigid Torque Arm, Upper, 15 7/8" Center-to-Center, Type 0 & 1 Joints	4
	R3014986	-	800049	Rigid Torque Arm, Upper, Curved Design 46-50K, Type 2 Joints	4
	R3014773	-	807250	Adjustable Torque Arm, 46K 21 3/4" Center-to-Center, Type 2 Joints	1
	R3014774	-	807216	Adjustable Torque Arm, 46K 25" Center-to-Center, Type 2 Joints	1
	R3014987	-	807214	Adjustable Torque Arm, 21 1/2" Center-to-Center, Type 2 Joints	1
	R3014976	-	807240	Adjustable Torque Arm, 24" Center-to-Center, Type 2 Joints	1
	R3014989	-	807220	Adjustable Torque Arm, 22" Center-to-Center, Type 2 Joints	1
	R3014978	-	805214	Rigid Torque Arm, 21 1/2" Center-to-Center, Type 2 Joints	1
	R3014990	-	805216	Rigid Torque Arm, 21 3/4" Center-to-Center, Type 2 Joints	1
	R3014991	-	805220	Rigid Torque Arm, 22" Center-to-Center, Type 2 Joints	1
8	R307773	-	K880231	Hardware Kit, Type 1 Joint	4
	R307774	-	K880460	Hardware Kit, Type 2 Joint	4
9	M85301	-	800670	Shock Absorber, High Mount	4
	M85305	-	800781	Shock Absorber, Low Mount	4
	M85060	-	665174	Shock Absorber, Standard Mount	4
10	R3014994	-	HDW372	Bolt, Shock Absorber 3/4"-10 x 5 1/2" Long	4
	R304345	-	HDW375	Bolt, Shock Absorber 3/4"-10 x 3 1/2" Long	4
11	R304347	-	HDW 018	Lock Nut, 3/4"-10 Thread	4
12	R302545	-	HDW 031	Washer, 3/4" Hardened	4
13	R307765	-	700313	Wear Plate	As Required

For the complete suspension and components offering, visit MeritorPartsXpress.com or check out the PB9968 series of the Suspension catalog on Meritor.com/LOD.



Truck, Drive Axle, Air Ride, Single or Multiple Axles, Transverse Torque Arm



The PRIMAAX is an air spring suspension designed for severe duty applications. This suspension features two front pivot bushings and two torque rods. The PRIMAAX suspension is commonly found on cement trucks, flatbed trucks and other specialty vocational applications. Each axle is independently supported allowing these suspensions to be stacked up for tandem or tridem applications.

Exploded View

SCAN FOR VISUAL SEARCH ON MERITORPARTSPRESS.COM

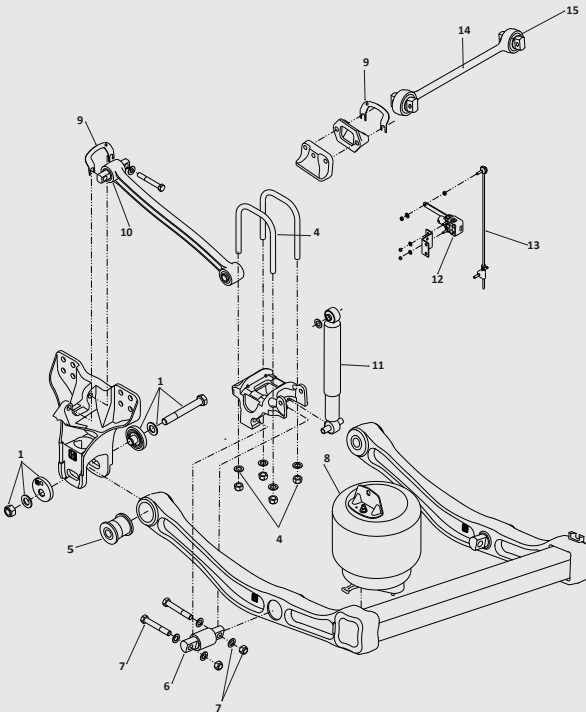

QUIK-ALIGN™ Pivot Bushing Kit
8 1/2" - 10" Ride Height

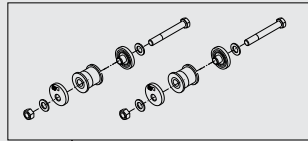

Hanger With One Torque Mounting Bolt
Primaax 230T/460T/690T &
Firemaxx 240T/480T

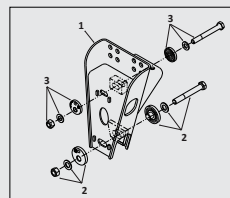



KEY NO.	MERITOR PART NO.	OEM REFERENCE	DESCRIPTION	QTY PER AXLE	
				PRIMAAX® EX 23K/26K S/46K/52K S/69K/78K S, FIREMAX EX 24K/27K S 48K/54K	PRIMAAX® EX 26K/52K/78K, FIREMAX EX 27K/31K/54K/62K
1	R3014673A	60632-019	Quik-Align Collar Service Kit, Not For Pierce Vehicles, One Wheel End	2	2
		60632-006			
2	R3014025	60632-020	Quik-Align Pivot Bushing Service Kit, Except For 12 1/2" or Larger Ride Heights With Disc Brakes, Includes Hardware and Bushing	1	1
	R3014033	60632-022 60632-009	Quik-Align Collar, Pivot Bushing & Single Bolt Torque Rod Service Kit, 12 1/2" Ride Height and Larger With Disc Brakes, Axle Set, Includes Hardware and Pivot Bushing	-	1
3	R3016262	58821-011	Torque Rod Fastener & Alignment Kit, One Wheel End	-	2
4	R30U8257-087	-	U-Bolt Assembly, Sq. Bend, 3/4"-16 Thd. x 6 3/8" Wide x 8 7/8" Long	4	
	R30U8257-11	-	U-Bolt Assembly, Sq. Bend, 3/4"-16 Thd. x 6 3/8" Wide x 11" Long	4	4
	R30U8257-12	-	U-Bolt Assembly, Sq. Bend, 3/4"-16 Thd. x 6 3/8" Wide x 12" Long	-	4
5	R3013992	58648-000	Pivot Bushing	2	2
6	R3014026	60383-000	"D" Pin Bushing Use with 3/4" Bolts	2	-
7	R3016351	21867-036	Bolt Kit 3/4"-16 x 5" Long, Includes Bolt and Hardware	1	-
	R3016123	21777-026	Bolt Kit 3/4"-16 x 5 1/2" Long, Includes Bolt and Hardware	4	-
8	See Chart	Various	Air Spring Assembly See Selection Guide	2	2
9	R305281	49689-000	Shim; 1/16" Thick, 4 3/8" Center to Center	As Required	-
10	R3010322	69210-000	Torque Rod Bushing; 4 3/8" Center-to-Center x 3/4" Bolts	-	-
	R305276	47692-000	Torque Rod Bushing, Through Holes, 7/8" ID x 2 1/32" OD x 3" Long	-	-
11	M85072	60657-003; 60657- 004; 60657-005; 60657-007	Shock Absorber, PRIMAAX EX	2	-
	M85965	60665-013	Shock Absorber, PRIMAAX EX, w/Drum Brakes	-	2
	M85966	60665-015	Shock Absorber, PRIMAAX EX, w/Air Disc Brakes	-	2
	M85967	60665-011	Shock Absorber, Oshkosh	2	-
12	R3011870	57977-000	Height Control Valve with Dump	1	1
13	R309625	-	Linkage Assembly; Universal Adjustable 3 5/8"-19 5/8" Range	1	1
14	Various	Various	Transverse Torque Rod, See Ultra Rod Section in Catalog	1	1
15	R3013961	64400-002	Torque Rod Bushing, Straddle Mount w/ 5/8" Bolt Holes, Use on Rods with 2 Straddle Mt Bushings	2	2
	R305275	47691-000	Torque Rod Bushing, Straddle Mount w/ 5/8" Bolt Holes, Use on Rods With 1 Tapered Bushing	1	As Required
	R3010308	64809-000	Torque Rod Bushing, Tapered	1	As Required

For the complete suspension and components offering, visit MeritorPartsXpress.com or check out the PB9968 series of the Suspension catalog on Meritor.com/LOD.



Truck, Drive Axle, Bolster Spring/Rubber Pad, Tandem, Transverse Torque Arm for High Capacities



The RS is a bolster spring suspension that features a maximum of six springs (four standard springs and two optional overload springs), two or three per side, and a walking beam with a central bushing that acts as a pivot point. This suspension is common for severe duty applications. This system also features the standard Hendrickson four end beam bushings.

Exploded View

SCAN FOR VISUAL SEARCH ON MERITORPARTSPRESS.COM

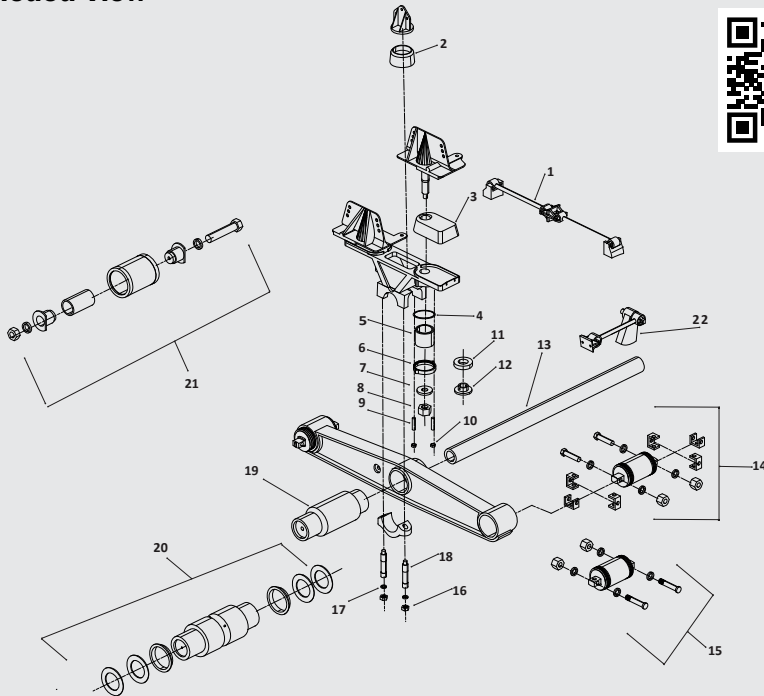

WEAR ITEMS

Bolster spring, center and end beam bushings.



TECH TIP

Load cushions that are cut or damaged should be replaced. The free height of new cushions is 3.94". Used cushions that measure less than 3.68" when measured on a flat surface have taken a permanent set and should be replaced.

KEY NO.	MERITOR PART NO.	OEM REFERENCE	DESCRIPTION	QTY. PER TANDEM
1	See Torque Rod Section Page 88	Various	Torque Rod Assembly, See Torque Rod Section	2
2	R302232	24209-000	Heavy-Duty Load Cushion RS-340/400/460/480/520	2
3	R301598A	48973-000	Load Cushion, 60 Durometer, Discontinued used R301960	4
	R301960	26953-000	Load Cushion, 70 Durometer	4
4	R309418	50780-000	Saddle Bushing Ring	4
5	R301940	19279-000	Bushing	4
6	R301941	05917-000	Cap	4
7	R301945	08536-000	Washer	4
8	R301946	25151-000	Nut, 1 1/2"-12	4
9	R301942	19111-001	5/8"-18, 5/8"-11 Bushing Cap Stud	8
10	R301943	19114-000	Nut, 5/8"-18	8
11	R302233	30208-000	Rebound Bumper	As Required
12	R307620	30251-000	Stop Nut	As Required
13	R301842	44643-009	Cross Tube, 44 7/8"	1
	R309426	07622-003	Cross Tube, 46"	1
14	R309325	34013-087	Bar Pin Bushing Kit, Non-Shim Type	4
15	R309326	34013-088	Bar Pin Bushing Kit, Shim Type	4
16	R301835	04842-000	7/8"-14 Saddle Cap Locknut	8
17	R301834	22962-002	7/8" Hardened Washer	8
18	R301947	09030-000	7/8"-14, 7/8"-9 Saddle Cap Stud	8
19	R301338	6664-000	Rubber Center Bushing Welded End Plug, RS340	2
	R301594	22279-000	Rubber Center Bushing Loose End Plug, RS340	2
	R306979	49400-000	Rubber Center Bushing Welded End Plug, RS400/460	2
	R306980	49600-000	Rubber Center Bushing Loose End Plug, RS400/460	2
	R309359	29483-005	Rubber Center Bushing Welded End Plug, RS460/480/520 Extreme Duty, Transverse Rods Required	2
20	R301545	30436-000	Bronze Center Bushing Kit, RS340	2
	R301546	30437-000	Bronze Center Bushing Kit, RS400/460/480/520	2
21	R305308	34013-048	End Beam Bushing Kit, RS340, Includes Bushing, Adapter & Hardware	4
	R305309	34013-049	End Beam Bushing Kit, RS400, Includes Bushing, Adapter & Hardware	4
	R309576	34013-073	End Beam Bushing Kit, RS460, Includes Bushing, Adapter & Hardware	4
	R309577	34013-050	End Beam Bushing Kit, RS480/520, Includes Bushing, Adapter & Hardware	4
22	R3013988	60215-000	Two-Piece Transverse Torque Rod Kit, Includes Bushings	2

For the complete suspension and components offering, visit MeritorPartsXpress.com or check out the PB9968 series of the Suspension catalog on Meritor.com/L0D.



SAF HOLLAND: AD-123 (NEWAY)

Truck, Drive Axle, Air Ride, Single or Multiple Axles, Transverse Torque Arm



The AD Series suspensions are air ride suspensions that come in three different versions. The AD-123 (23,000 lbs), AD-126 (26,000 lbs), and AD-130 (30,000 lbs). This suspension is commonly used on vocational trucks such as liquid hauler trucks, cement trucks and other specialty applications. Each axle is independently supported allowing these suspensions to be stacked up for tandem or tridem applications.

Exploded View

SCAN FOR VISUAL SEARCH ON MERITORPARTSPRESS.COM

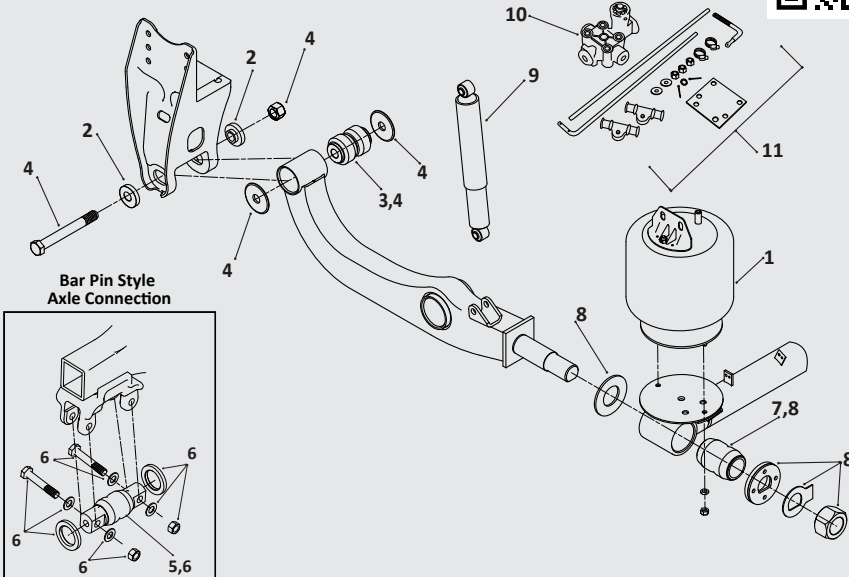



KEY NO.	MERITOR PART NO.	MACH PART NO.	OEM REF.	DESCRIPTION	QTY. PER TANDEM
1	FS9471	-	90557146	Firestone Air Spring, Includes Mounting Bracket, 10" Ride Height	2
	MAF9471	-	90557146	Meritor Air Spring, Includes Mounting Bracket, 10" Ride Height	2
	FS9472	-	90557147	Firestone Air Spring, Includes Mounting Bracket, 6.75" & 8.75" Ride Height	2
2	R304267	-	90008120	Alignment Block, AD123 & AD126 Only	2
3	R309292	G-9292	90008252	Beam Bushing, Pivot, Rubber, AD123 & AD126 Only	2
	R3016567	-	90008256	Bushing, Front Pivot, Rubber, AD130 Only	2
4	R309300A	-	48100260/SRK-200	Pivot Connection Kit, Includes Bushing & Hardware, AD123 & AD126 Only	1
	R3016589	-	48100429/SRK-565	Connection Kit, Front Pivot, Heavy Duty, Includes Bushing & Hardware, AD130 Only	1
5	R3010678	-	90008175	Bushing, Axle Connection, Bar Pin Style, Rubber, AD123 Only	2
	R3016636	-	90508012	Bushing, Axle Connection, Bar Pin Style, Rubber, AD126 Only	2
6	R3015340	-	48100315/SRK-452	Connection Kit, Axle, Bar Pin Style, Includes Hardware & Bushing, AD123 Only	1
	R3016638	-	48100313/SRK-450	Connection Kit, Axle Bar Pin, Includes Hardware & Bushing, AD126 Only	1
7	R304252	G-4252	90008219	Bushing, Transverse Beam, Rubber, AD123 & AD126 Only	2
	R309293	G-9293	90008135	Bushing, Transverse Beam, Rubber, AD130 Only	2
8	R3016624	-	48100276/SRK-214	Transverse Beam Connection Kit, Includes Bushing, Nut & Spacer Assembly, AD123 Only	1
	R3016577	-	48100335/SRK-472	Transverse Beam Connection Kit, Includes Bushing, Nut & Spacer Assembly, AD126 Only	1
	R3016608	-	48100364/SRK-500	Transverse Beam Connection Kit, Includes Bushing, Nut & Spacer Assembly, AD130 Only	1
9	M85906	-	90045099	Shock Absorber	2
	M85909	-	90045132	Shock Absorber (Optional, 24 1/4" Extended Length)	2
10	R3013922	-	90554241	Height Control Valve	1
11	R3016623	-	48100267/SRK-205	Linkage, Height Control Valve	1

For the complete suspension and components offering, visit MeritorPartsXpress.com or check out the PB9968 series of the Suspension catalog on Meritor.com/LOD.







VOCATIONAL TRAILERS



HUTCH:
H900



MERITOR®:
MTA



REYCO:
21B



Trailer, Single Point Leaf Spring



H900 is a spring suspension that is a single point trunnion style. The system features leaf springs that pivot on a trunnion and extend out to the spring end caps. The spring end caps have rubber pads around the springs to reduce wear and increase ride performance. This system is commonly used on dump trailers. There are many trunnion and axle mounting options for these suspensions which require careful review.

Exploded View

SCAN FOR VISUAL SEARCH ON MERITORPARTSEXPRESS.COM

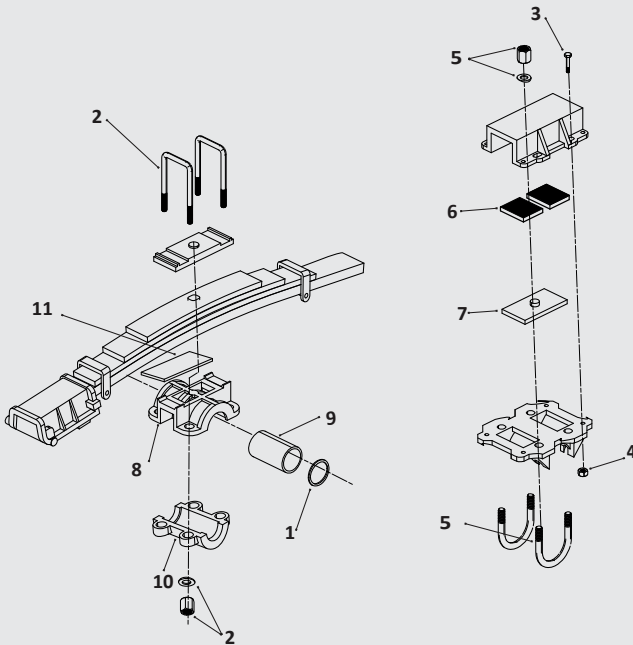

WEAR ITEMS

Trunnion bushing, spring end pads.



KEY NO.	MERITOR PART NO.	MACH PART NO.	OEM REF.	DESCRIPTION	QTY. PER TANDEM
1	R305219	-	895-00	Trunnion Washer, 4" ID x 5 3/4" OD x 3/16" Thick	2
2	R30U8286-134	-	9639-01, 9639-02	U-Bolt Assembly, Sq. Bend, 1 1/8"-12 Thd. X 5 1/8" Wide x 13 1/2" Long	4
	R30U8286-154	-	9639-03, 9639-04, 9639-05	U-Bolt Assembly, Sq. Bend, 1 1/8"-12 Thd. x 5 1/8" Wide x 15 1/2" Long	4
3	R304348	-	-	Hex Bolt 5/8"-11 x 2" Long	16
4	R302988	-	-	Hex Locknut 5/8"-11	16
5	R30U8155-073	-	10060-01	U-Bolt Assembly, Rd. Bend, 3/4"-16 Thd. x 5" Wide x 7 3/8" Long	8
	R30U8156-08	-	10061-01	U-Bolt Assembly, Rd. Bend, 3/4"-16 Thd. x 5 3/4" Wide x 8" Long	8
	R30U8157-08	-	10062-01	U-Bolt Assembly, Rd. Bend, 3/4"-16 Thd. x 6" Wide x 8" Long	8
	R30U8175-104	-	10064-01, 10064-02	U-Bolt Assembly, Rd. Bend, 1"-14 Thd. x 5" Wide x 10 1/2" Long	8
	R30U8177-114	-	10065-01	U-Bolt Assembly, Rd. Bend, 1"-14 Thd. x 5 3/4" Wide x 11 1/2" Long	8
	R30U8176-114	-	10066-01	U-Bolt Assembly, Rd. Bend, 1"-14 Thd. x 6" Wide x 11 1/2" Long	8
	R30U8256-077	-	10063-02	U-Bolt Assembly, Sq. Bend, 3/4"-16 Thd. x 5" Wide x 7 7/8" Long	8
	R30U8271-104	-	10067-02	U-Bolt Assembly, Sq. Bend, 1"-14 Thd. x 5" Wide x 10 1/2" Long	8
	R30U8271-111	-	10067-03	U-Bolt Assembly, Sq. Bend, 1"-14 Thd. x 5" Wide x 11 1/8" Long	8
6	R305227	G-5227	814-00	Spring End Pad, Rubber	8
	R308665	-	-	Spring End Pad, Poly	8
7	R305228	G-5228	10608-00	Alignment Adjustment Plate 3/8" Thick	4
	R3015463	-	19059-01	Alignment Adjustment Plate 5/8" Thick	4
8	R305210	G-5210	891-00	Upper Trunnion Hub	2
9	R305216	G-5216	890-00	Trunnion Bushing, Rubber	2
	R307455	-	-	Trunnion Bushing, Poly	2
	R3016397	-	23276-01	Free Oscillating Trunnion Bushing	2
10	R305211	G-5211	898-00	Lower Trunnion Hub, Overstung	2
	R305212	-	892-00	Lower Trunnion Hub, Underslung Trunnion	2
11	R3025197	-	12919-01	Spring Liner Pad, 4 3/4" Wide x 10" Long	2

For the complete suspension and components offering, visit MeritorPartsXpress.com or check out the PB9968 series of the Suspension catalog on Meritor.com/L0D.



Trailer, Air Ride, Single Axle



The MTA suspension is a trailing arm air suspension. It comes in five versions, three top-mount models ranging from 23,000- to 30,000-pound capacities and two recently introduced low-mount models in 25,000- and 30,000-pound per axle capacities. The MTA suspension features a distinctive groove or channel in the outer alignment collar.

Exploded View

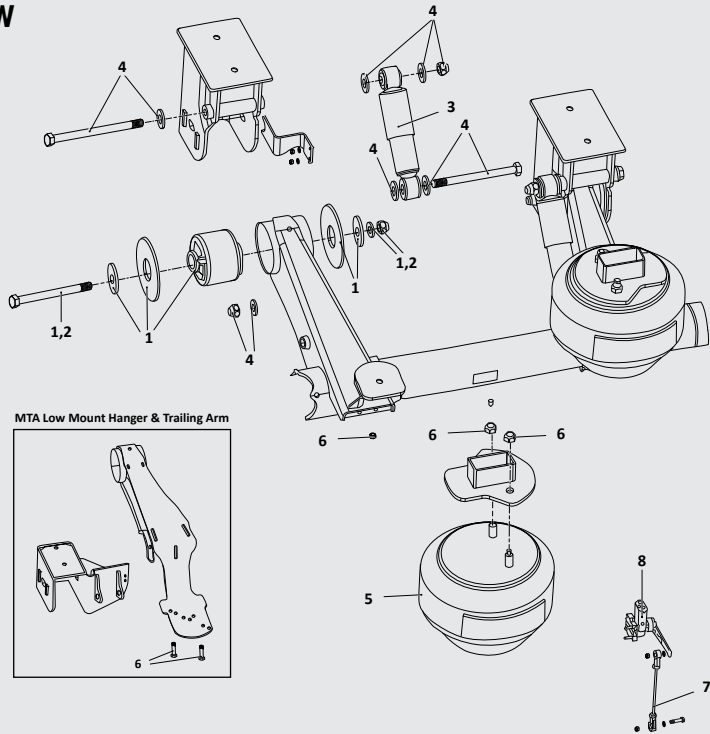

SCAN FOR VISUAL SEARCH ON MERITORPARTSPRESS.COM



TECH TIP

Loose fasteners that are allowed to operate for any period of time will result in irreversible damage. Retightening a worn fastener will not correct a situation created by loose operation. It is imperative that fastener and other affected parts including bushings be replaced.

KEY NO.	MERITOR PART NO.	OEM REF.	DESCRIPTION	QTY. PER TANDEM
1	KIT 11350	KIT 11350	Pivot Bolt and Bushing Kit, MTA23T Only, Includes Bushing, Alignment Collars, & Hardware	2
	KIT 11351	KIT 11351	Pivot Bolt and Bushing Kit, All MTA25 & 30 Models, Includes Bushing, Alignment Collars, & Hardware	2
2	KIT 11352	KIT 11352	Pivot Bolt Kit, MTA23T Only, Includes Bolt, Washers & Nut	2
	KIT 11353	KIT 11353	Pivot Bolt Kit, All MTA25 & 30 Models, Includes Bolt, Washers & Nut	2
3	A-7805-F-1020	A-7805-F-1020	Shock Absorber, All Top Mount Models	2
	A-7805-S-1163	A-7805-S-1163	Shock Absorber, All Low Mount Models	2
4	KIT 11356	KIT 11356	Shock Absorber Hardware Kit, All Top Mount Models, Includes Bolts, Washers & Nuts	2
	KIT 11432	KIT 11432	Shock Absorber Hardware Kit, All Low Mount Models, Includes Bolts, Washers & Nuts	2
5	A-2258-H-1568	A-2258-H-1568	Air Spring, MTA23T Only	2
	A-2258-P-1576	A-2258-P-1576	Air Spring, MTA25T Only	2
	A-2258-Q-1577	A-2258-Q-1577	Air Spring, MTA30T Only	2
	A-2258-S-1605	A-2258-S-1605	Air Spring, MTA25L & 30L, 6.5"-8" Ride Height	2
	A-2258-J-1726	A-2258-J-1726	Air Spring, MTA25L & 30L, 9"-11" Ride Height	2
	A-2258-T-1606	A-2258-T-1606	Air Spring, MTA25L & 30L, 12"-19" Ride Height	2
6	KIT 11203	KIT 11203	Air Spring Hardware Kit, Top Mount Only, Includes Upper and Lower Nuts	2
	KIT 11455	KIT 11455	Air Spring Hardware Kit, Low Mount Only, Includes Upper Nuts and Lower Bolts	2
7	203159-5	203159-5	Linkage Assembly	1
8	A-7806-M-1053	A-7806-M-1053	Height Control Valve, Remove Air to Dump, All Top Mount Models	1
	A-7806-L-1052	A-7806-L-1052	Height Control Valve, No Dump, All Top Mount Models	1
	A-7806-Y-1065	A-7806-Y-1065	Height Control Valve, Remove Air to Dump, All Low Mount Models	1
	A-7806-X-1064	A-7806-X-1064	Height Control Valve, No Dump, All Low Mount Models	1

For the complete suspension and components offering, visit MeritorPartsXpress.com or check out the PB9968 series of the Suspension catalog on Meritor.com/L0D.



Trailer, Leaf Spring, Tandem or More Axles



Reyco 21B is a leaf spring suspension that comes in multiple axle spacing configurations, 44" to 60". The suspension comes in two major variants the cast and fabricated version. The hangers and equalizers for each version are not interchangeable. The Reyco 21B is popular with vocational trailers.

Exploded View

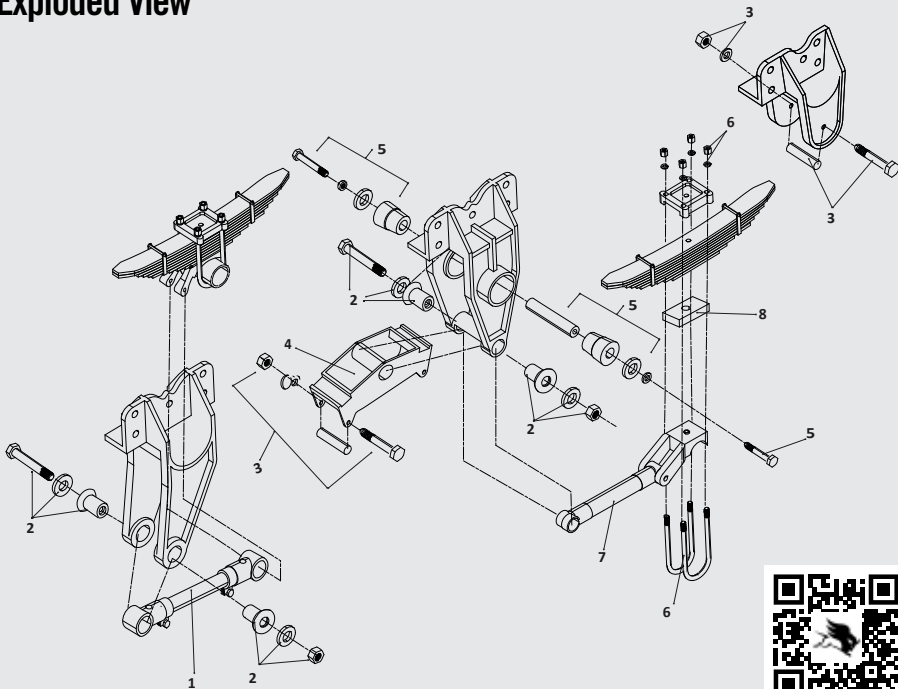

SCAN FOR VISUAL SEARCH ON [MERITORPARTSEXPRESS.COM](https://www.meritorpartsexpress.com)

WEAR ITEMS

Equalizers and bushing, torque arms and bushings.



KEY NO.	MERITOR PART NO.	MACH PART NO.	OEM REF.	DESCRIPTION	QTY. PER TANDEM
1	R303283A	G3283A	15172-01	Adjustable Torque Arm without Bushings, Rear 42"–44" Axle Spacing, Front 49"–109" Axle Spacing	1
	R303284A	G3284A	15173-01	Adjustable Torque Arm without Bushings, Rear 49"–109" Axle Spacing	1
	R305255A	-	15176-01	Adjustable Torque Arm, Rear 60" Axle Spacing, 25" Center-to-Center	1
2	R301312A	-	TK18997	Torque Arm Bushing Kit Includes Rubber Bushing and Hardware	8
	R309545	-	-	Torque Arm Bushing Kit Includes Poly Bushing and Hardware	8
3	R301975	G1975	TK19011	Spring Roller Assembly Includes Roller and Hardware	6
4	R302846A	-	21725-01	ADI Equalizer without Bushing, 49" Axle Spacing	2
	R3010768A	G10768A	25222-01	ADI Equalizer without Bushing, 42"–44" Axle Spacing	2
	R3016477	-	T-5427	Equalizer, Steel 49"	2
5	R303976	-	TK18998	Equalizer Bushing Assembly Includes Rubber Bushing and Hardware	2
	R309555	-	-	Equalizer Bushing Assembly Includes Poly Bushing and Hardware	2
6	R30U5165-14	-	Various	U-Bolt Assembly, Rd. Bend, 7/8"-14 Thd. x 5" Wide x 14" Long	8
	R30U5165-18	-	Various	U-Bolt Assembly, Rd. Bend, 7/8"-14 Thd. x 5" Wide x 18" Long	8
	R30U5161-14	-	Various	U-Bolt Assembly, Rd. Bend, 7/8"-14 Thd. x 3" Wide x 14" Long	8
	R30U5161-18	-	Various	U-Bolt Assembly, Rd. Bend, 7/8"-14 Thd. x 3" Wide x 18" Long	8
7	R302855	-	15178-01, T-7635	Torque Arm, Rigid, without Bushings, Rear 44" Axle Spacing, Front 49"–109" Axle Spacing	1
	R302856	-	15179-01, T-2293	Torque Arm, Rigid, without Bushings, Rear 49" Axle Spacing	1
	R302855	-	T-7635	Torque Arm, Rigid, Rear 44", Front 50"–109" Axle Spacing, 16 1/4" Center-to-Center	1
8	R309562	-	T-7555	Spacer, 1/2"	As Req.
	R309563	G9563	T-7716	Spacer, 1"	As Req.
	R309564	-	T-7654	Spacer, 1 1/2"	As Req.
	R302878	-	T-7655	Spacer, 2"	As Req.
-	R309559	-	11851-01	Equalizer Stiffener Plate , Steel Equalizer Only	As Req.
	R309560	-	11852-01	Equalizer Wear Pad, Steel Equalizer Only	As Req.
	R309561	G9561	15630-01	Hanger Weld-On Wear Plate, Front & Rear	As Req.

For the complete suspension and components offering, visit MeritorPartsXpress.com or check out the PB9968 series of the Suspension catalog on Meritor.com/LOD.



APPENDIX

HOW TO IDENTIFY YOUR REAR TRUCK AND TRAILER SUSPENSION

REAR TRUCK AIR SUSPENSION



FREIGHTLINER: FAS II AIRLINER®

Identifiable by the long thin solid hanger. The genuine hanger has “AirLiner” cast into the part. (PG 6–7)



HENDRICKSON: PRIMAAAX®

The PRIMAAAX features a square transverse beam connecting the two pivot beams connected the hangers. The hangers feature the Hendrickson logo and an alignment collar that features the Hendrickson logo. (PG 64–65)



KENWORTH: AIRGLIDE 100

Identifiable by larger center hanger with two torsion bars connected at the bottom. This style of hanger is very unique to this suspension. (PG 8–9)



KENWORTH: AIRGLIDE 200®–400®

Newer version of the Kenworth 100. Identifiable by larger center hanger with two torsion bars connected at the bottom. The 200–400 series has a “V” cut out of the top of the hanger. (PG 10–11)



MACK/VOLVO: CORPORATE AIR

Identifiable by the unique hanger with a lower appendage that sits forward of the main body of the hanger. The genuine hanger typically has “Mack” or “Volvo” cast into the part. (PG 12–13)

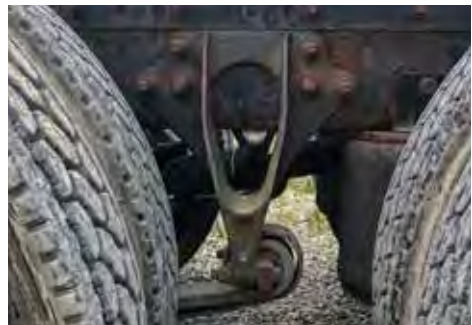

NAVISTAR/INTERNATIONAL®: CORPORATE AIR

Identifiable by the long thin hanger with a hole cut out of the center. (PG 14–15)

REAR TRUCK AIR SUSPENSION



PETERBILT: AIR LEAF

Identifiable by the unique mounting method for the spring. There are two bolts that connect the spring to the hanger. The bolts are located below the spring on the Air Leaf and there is no torque arm connecting the hanger to the axle. (PG 16–17)



PETERBILT: AIR TRAC

The leaf spring is not attached to the hanger as it slides within the hanger on a wear pad. The torque arm mounts to the hanger immediately below the spring connecting to the axle. (PG 18–19)



PETERBILT: AIRGLIDE 210

Identifiable by the shorter hanger with the spring eye bushing mounted to the rear of the hanger. The genuine hanger typically has “Paccar” cast into the part. (PG 20–21)



PETERBILT: FLEX AIR

Identifiable by the unique curved flex spring visible between the wheels. (PG 22–23)



SAF HOLLAND: AD-123 (NEWAY)

Identifiable by the long curved equalizer beam assembly. This beam is connected to the opposing equalizer beam by a transverse beam assembly that supports the air springs. (PG 68–69)

TRAILER FOUR SPRING TANDEM AXLE SUSPENSION



HUTCH: H7700/9700

Identifiable by the shape of the equalizer and the diameter of the center bolt, 1 1/8". The Reyco 88 uses a similar style equalizer but has a 1" bolt. (PG 28–29)



REYCO: 21B

Identifiable by the large washer located on the center hanger. (PG 76–77)



SAF HOLLAND: DURALITE (BINKLEY)

Identifiable by the straight bottom on the center hanger and the two holes located on either end of the equalizer. (PG 34–35)

SINGLE POINT OR TWO SPRING TANDEM AXLE SUSPENSION



FREIGHTLINER: TUFTRAC®

Identifiable by the large bolster spring mounted above the leaf springs. (PG 40–41, 52–53)



HENDRICKSON: RT®

Identifiable by the walking beam connected to the bottom of the leaf spring stack. (PG 46–47)



HUTCH: H900

Identifiable by trunnion housing located below the leaf spring and the lack of torque rods. Can be easily mistaken for Neway and Watson & Chalin trunnion suspension that are very similar. (PG 72–73)



MACK: SS44 SERIES, CAMELBACK

Identifiable by the large hump in the leaf spring stack, lending to the suspension's name. (PG 48–49, 58–59)

TRAILER TRAILING ARM AIR SUSPENSIONS



HENDRICKSON: INTRAAX®

Identifiable by the Hendrickson logo found on the outer alignment washer. The width of the bottom of the hanger for the wide bushing versions is 7.25", for the narrow bushing versions it is 4.12". The ULTRAA-K version is easily identifiable by the unique shape of the hanger, this suspension uses the narrow bushing. (PG 26–27)



MERITOR®: MTA

Identifiable by the unique groove or channel in the outer alignment washer. (PG 74–75)



SAF HOLLAND: CBX23/25

Identifiable by the rounded bottom of the hanger and the adjustment mechanism mounted to the front of the hanger. (PG 32–33)

TRUCK BOLSTER SPRING SUSPENSIONS



CHALMERS: 800 SERIES

Identifiable by the single bolster spring located directly on top of the walking beam, this suspension also features two torque arms below the walking beam. (PG 38–39, 62–63)



HENDRICKSON: HAULMAAX®

Identifiable by four ribbed bolster springs, the HAULMAAX model has four bolster springs per side. (PG 42–43, 54–55)



HENDRICKSON: HN®

Identifiable by two large ribbed bolster springs, the HN model only features two bolster springs per side. (PG 44–45, 56–57)



HENDRICKSON: RS®

Identifiable by the bolster springs sitting directly below the frame, this suspension can have 2–3 bolster springs per side. (PG 66–67)



APPENDIX

HENDRICKSON COMPONENTS

ULTRA ROD® (TRUCK SUSPENSION ONLY)

ULTRA ROD OPTION CONFIGURATIONS

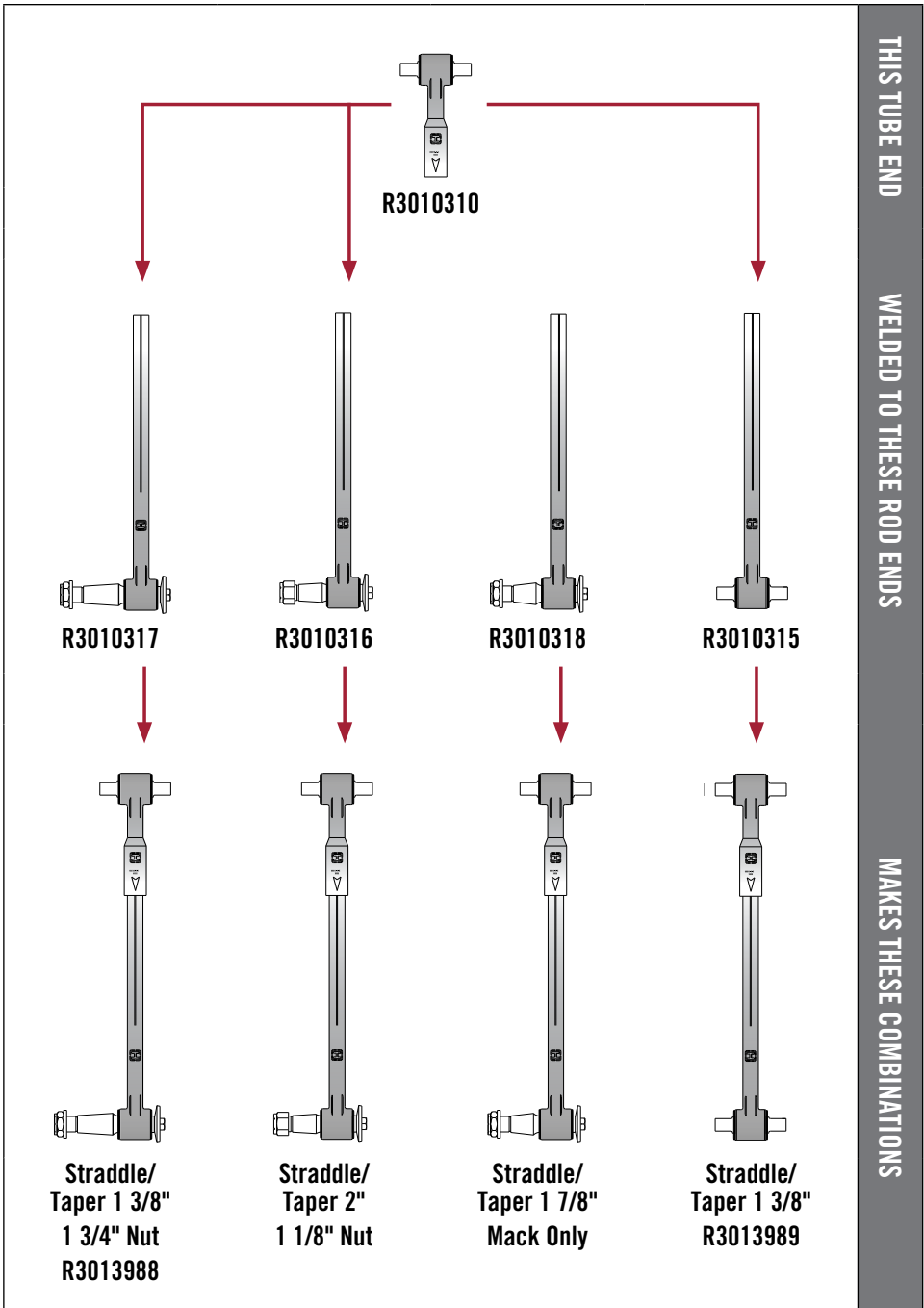

ULTRA ROD® (TRUCK SUSPENSION ONLY)

ULTRA ROD OPTION CONFIGURATIONS



R3010314

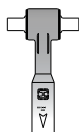

R3010310*

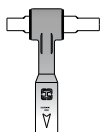

R3010313*

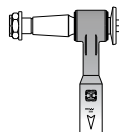

R3010312

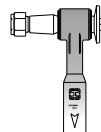

R3010311

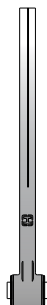

R3010319

* R3010310 & R3010313 are not interchangeable

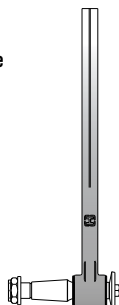

R3010317
For NAVISTAR (IHC) Only

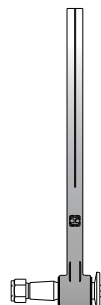

R3010316

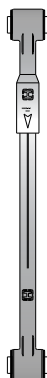

Hollow Sleeve/
Hollow Sleeve

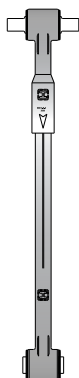

Std. Straddle/
Hollow Sleeve

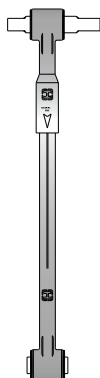

Offset Straddle/
Hollow Sleeve

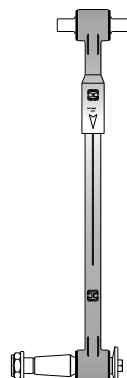

Straddle/
Taper 3"
1 1/4" Nut

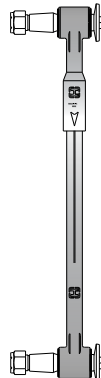

Straddle/
Taper 2"
1 1/8" Nut

THIS TUBE END

WELDED TO THESE ROD ENDS

MAKES THESE COMBINATIONS

UNI-ROD® KITS: INDIVIDUAL COMPONENTS

Uni-Rod Kits Require Two Ends and a Connector Tube

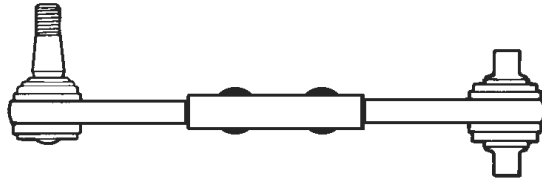

UNI-ROD BALL STUD

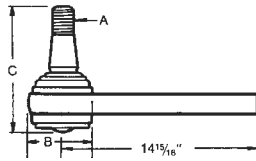

Thread	Meritor Nut
1 1/8"-12	= R302079
1 1/4"-12	= R302017

Nut Not Furnished

MERITOR NO.	OEM REF.	A THREAD	B	C
R303165	O&S BU 235	1 1/8"-12	3 3/8"	6 9/64"
R303166	O&S MU 239	1 1/4"-12	3 3/8"	6 11/64"
R303167	O&S BU 347	1 1/4"-12	3 3/4"	7 43/64"
R303168	O&S MU 318	1 1/4"-12	3 3/4"	6 39/64"

UNI-ROD HOLLOW BALL

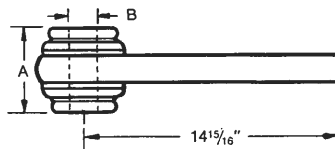

MERITOR NO.	OEM REF.	A	B
R303169	O&S HU 351	3 1/4"	1 1/8"

NOTE: Nuts and Washers Furnished with Kits Only.

UNI-ROD STRADDLE ARM



MERITOR NO.	OEM REF.	HOLE DIA.	A	B	C
R303170	O&S SU 236	21/32"	3 3/8"	3 3/8"	4 3/8"
R303171	O&S SU 348	21/32"	3 3/4"	3 3/8"	4 3/8"
R303987	O&S BU 372	29/32"	3 3/4"	3 3/4"	4 3/8"

UNI-ROD OFFSET STRADDLE BALL

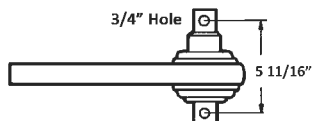

MERITOR NO.	OEM REF.
R303185	O&S SU 359

UNI-DAPTOR (CONNECTOR TUBE)

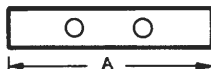

MERITOR NO.	OEM REF.	A
R303172	O&S 8151-1	8"
R303173	O&S 8607-1	18"

INTRAAX® SERIES AIR SPRING SELECTION GUIDE

INTRAAX SERIES SUSPENSION AIR SPRING SELECTION GUIDE			
MODEL	MERITOR NO.	OEM REF.	NOTES AND COMMENTS
AAEDL	S.O.S.	S-24445	9" Ride Height
	S.O.S.	S-24446	12"-19" Ride Height
AAEDT 30K	S.O.S.	S-25319	All
AAL 23K/25K/30K	FS9626 / MAF9626	S-23720	23K - 6 1/2"-7 1/2" Ride Height
	FS9621	S-23613	23K - 8"-9" Ride Height
	FS9619	S-23614	23K - 12"-19" Ride Height
	FS9644 / MAF9644	S-23721	25K - 6 1/2"-7 1/2" Ride Height
	FS9646 / MAF9646	S-23611	25K - 8"-9" Ride Height
	FS9645 / MAF9645	S-23612	25K - 12"-19" Ride Height
	S.O.S.	S-25871	30K - 8"-9" Ride Height
	S.O.S.	S-25872	30K - 12"-19" Ride Height
AANL 23K	FS9626 / MAF9626	S-23720	6 1/2"-7 1/2" Ride Height Standard Pressure
	FS9621	S-23613	8"-9" Ride Height Standard Pressure
	FS9619	S-23614	12"-17" Ride Height Standard Pressure
	FS9644 / MAF9644	S-23721	6 1/2"-7 1/2" Ride Height Low Pressure
	FS9646 / MAF9646	S-23611	8" Ride Height Low Pressure
	FS9645 / MAF9645	S-23612	12"-17" Ride Height Low Pressure
AANLS 20K	FS9644 / MAF9644	S-23721	All
AANT 23K	FS8614	S-26773	12"-13" Ride Height
	FS8709 / MAF8709	S-21800	13 1/2"-19" Ride Height Standard Pressure
	FS8091 / MAF8091	S-20901	13 1/2"-19" Ride Height Low Pressure
AAT	FS8709 / MAF8709	S-21800	23K Models
	FS8091 / MAF8091	S-20901	25K Models
	FS8774 / MAF8774	S-25873	30K Models
AAZL 23/46K	FS9626 / MAF9626	S-23720	6 1/2"-7 1/2" Ride Height Standard Pressure
	FS9621	S-23613	8"-9" Ride Height Standard Pressure
	FS9619	S-23614	12" Ride Height Standard Pressure
	FS9644 / MAF9644	S-23721	6 1/2"-7 1/2" Ride Height Low Pressure
	FS9646 / MAF9646	S-23611	8"-9" Ride Height Low Pressure
	FS9645 / MAF9645	S-23612	12" Ride Height Low Pressure

INTRAAX® SERIES AIR SPRING SELECTION GUIDE

INTRAAX SERIES SUSPENSION AIR SPRING SELECTION GUIDE (CONT'D)			
MODEL	MERITOR NO.	OEM REF.	NOTES AND COMMENTS
AAZL 23/46K	FS9626 / MAF9626	S-23720	6 1/2"-7 1/2" Ride Height Standard Pressure
	FS9621	S-23613	8"-9" Ride Height Standard Pressure
	FS9619	S-23614	12" Ride Height Standard Pressure
	FS9644 / MAF9644	S-23721	6 1/2"-7 1/2" Ride Height Low Pressure
	FS9646 / MAF9646	S-23611	8"-9" Ride Height Low Pressure
	FS9645 / MAF9645	S-23612	12" Ride Height Low Pressure
AAZNT 23K	FS8709 / MAF8709	S-21800	13 1/2"-17" Ride Height Standard Pressure
	FS8091 / MAF8091	S-20901	13 1/2"-17" Ride Height Low Pressure
HKANT 40K	FS8713 / MAF8713	S-22948	Before Jan 2008
	FS9977	S-28929	After Jan 2008
HKANT69K23	FS8709 / MAF8709	S-21800	15" Ride Height
	FS8708 / MAF8708	C-21966	16" & 18" Ride Height
HKANT/HKAT 46K/HKA200	FS8709 / MAF8709	S-21800	Less Than 16" Ride Height
	FS8713 / MAF8713	S-22948	16" & Larger Ride Height
HKAT 50K/HKA250	FS8091 / MAF8091	S-20901	14"-15" Ride Height
	FS8093	S-23748	16"-19" Ride Height
HKAT 69K25	FS8093	S-23748	All
ULTRAA-K UTKNT 40K	S.O.S. - ZMD	S-34733	All
Vantraax HKAL 46K	FS9621	S-23613	9, 10, and 11" Ride Height
Vantraax HKARL 46K Slider	FS9619	S-23614	12" Ride Height
	FS9621	S-23613	All

Note: Part Numbers Beginning with FS are Genuine Firestone Air Springs. Part Numbers Beginning with MAF are Meritor Air Springs.

INTRAAX SERIES SUSPENSION SHOCK ABSORBER SELECTION GUIDE

MODEL	MERITOR NO.	OEM REF.	DESCRIPTION	NOTES AND COMMENTS
AAEDL	M85939	S-24579	Standard Duty Shock	Front; 9" Ride Height
	M85738	S-24023	Standard Duty Shock	Front; 12" Ride Height
	M85382	S-23316	Standard Duty Shock	Front; 14"-19" Ride Height
	M85916	S-25436	Standard Duty Shock	Rear; 9"-12" Ride Height
	M85337	S-25437	Standard Duty Shock	Rear; 14"-17" Ride Height
AAEDT 30K	M85382	S-23316	Standard Duty Shock	Front; 14" Ride Height; Extended Service & High Damping
	M85338	S-25515	Standard Duty Shock	Front; 15" & 17" Ride Height; Extd Service & High Damping
	M85916	S-25436	Standard Duty Shock	Rear; 14" & 15" Ride Height; Extended Service
	S.O.S.	S-25512	Standard Duty Shock	Rear; 16" & 17" Ride Height; Extended Service
AAL 23K/25K/30K	M85045	S-23651	Standard Duty Shock	Front Standard; 6 1/2"-9" Ride Height
	M85000	S-23566	Standard Duty Shock	Front Standard; 12" Ride Height
	M85029	S-2212	Standard Duty Shock	Front Standard; 14"-19" Ride Height
	S.O.S.	S-20345	Standard Duty Shock	Rear; 6 1/2"-7 1/2"; Ride Height
	M85939	S-24579	Standard Duty Shock	Rear; 6 1/2"-9" Ride Height; Extended Service
	M85916	S-25436	Standard Duty Shock	Rear; 9"-12" Ride Height
	M89430		Premium Adjustable Shock Absorber	
	M85738	S-24023	Standard Duty Shock	Rear; 12" Ride Height; Extended Service
	M85382	S-23316	Standard Duty Shock	Rear; 14"-19" Ride Height; Extended Service
	M85337	S-25437	Standard Duty Shock	Rear; 14"-17 1/2" Ride Height
AANL 23K	M85045	S-23651	Standard Duty Shock	6 1/2"-9" Ride Height; Standard
	M85939	S-24579	Standard Duty Shock	6 1/2"-9" Ride Height; Extended Service
	M85338	S-25515	Standard Duty Shock	12"-17" Ride Height; Extended Service
AANLS 20K	M85045	S-23651	Standard Duty Shock	Front Standard; 6 1/4"-9" Ride Height
	M85000	S-23566	Standard Duty Shock	Front Standard; 12" Ride Height
	M85338	S-25515	Standard Duty Shock	Rear; 6 1/4"-7" Ride Height
	M85382	S-23316	Standard Duty Shock	Rear; 9" Ride Height
	M85939	S-24579	Standard Duty Shock	6 1/4"-9" Ride Height; Extended Service & High Damping
	M85738	S-24023	Standard Duty Shock	12" Ride Height; Extended Service & High Damping

INTRAAX SERIES SUSPENSION SHOCK ABSORBER SELECTION GUIDE (CONT'D)

MODEL	MERITOR NO.	OEM REF.	DESCRIPTION	NOTES AND COMMENTS
AANT 23K	M85938	S-23743	Standard Duty Shock	Front; 12" Ride Height; Extended Service and High Damping
	M85939	S-24579	Standard Duty Shock	Front; 13" Ride Height; Extended Service
	M85045	S-23651	Standard Duty Shock	Front; 13" Ride Height; Standard
	M85911	S-23361	Standard Duty Shock	13 1/2"–17" Ride Height; Standard / 13 1/2"–19" Ride Height Limited Rebound
	M85000	S-23566	Standard Duty Shock	13 1/2"–19" Ride Height; Standard
	M85738	S-24023	Standard Duty Shock	13 1/2"–19" Ride Height; Extended Service with High Damping
AAT	M85738	S-24023	Standard Duty Shock	All 30K & some 23 & 25K with High Damping
	M85000	S-23566	Standard Duty Shock	Standard Duty all 23 & 25K
	M85911	S-23361	Standard Duty Shock	Limited rebound all 23 & 25K
AAZL 23/46K	M85045	S-23651	Standard Duty Shock	6 1/2"–9" Ride Height; Standard
	M85000	S-23566	Standard Duty Shock	12" Ride Height; Standard
	M85939	S-24579	Standard Duty Shock	6 1/2"–9" Ride Height; Extended Service
	M85738	S-24023	Standard Duty Shock	12" Ride Height; Extended Service
AAZNT 23K	M85000	S-23566	Standard Duty Shock	12"–17" Ride Height; Standard Travel
	M85738	S-24023	Standard Duty Shock	12"–17" Ride Height
HKANT 40K	M83128	S-24088	Standard Duty Shock	All
HKANT46K	M85000	S-23566	Standard Duty Shock	All
HKANT69K	M85000	S-23566	Standard Duty Shock	All
HKAT 46K/HKA200	M85000	S-23566	Standard Duty Shock	All
HKAT 50K/HKA250	M85738	S-24023	Standard Duty Shock	All
HKAT 69K25	M85738	S-24023	Standard Duty Shock	All
"ULTRAA-K UTKNT 40K"	ZMD Air Spring/Shock Absorber	Various	Shock Absorber	All
Vantraax HKAL 46K	M85000	S-23566	Standard Duty Shock	All
Vantraax HKARL 46K Slider	M85000	S-23566	Standard Duty Shock	With Drum Brakes
	M85916	S-25436	Standard Duty Shock	With Air Disk Brakes



APPENDIX

HEIGHT CONTROL VALVES

HEIGHT CONTROL VALVE SELECTION PROCESS

Height Control Valve Selection Process

Three steps are required to determine the proper valve:

Step 1: Determine if a dump valve is required,

Step 2: Select the valve manufacturer and model and

Step 3: Choose the proper arm length, mounting style and brackets.

STEP 1 – DETERMINE THE TYPE OF VALVE THAT IS REQUIRED. DOES THE HCV ALSO NEED TO DUMP AIR TO THE AIR SPRINGS WHEN EITHER:

- A. An actuation button is pushed on the dash or in some other location.
- B. The air is removed from the brake system thereby locking the spring brakes.

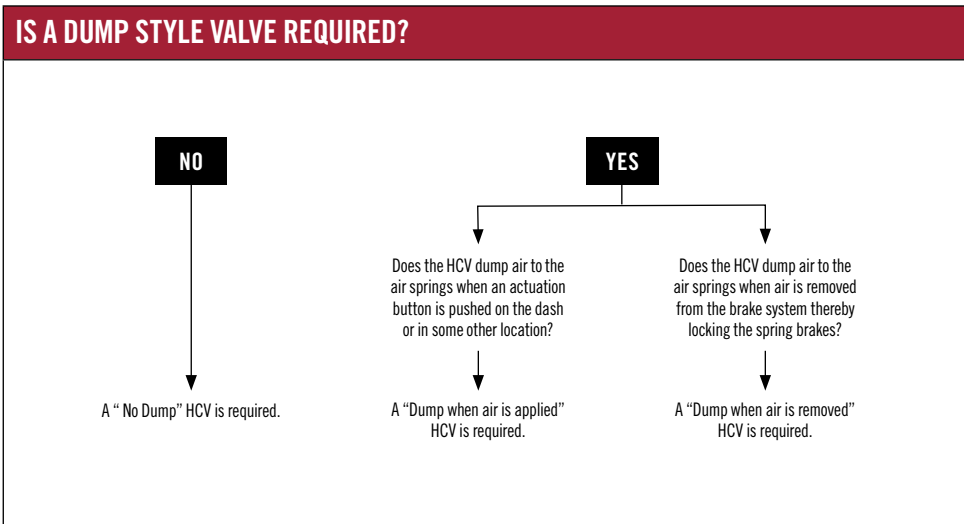

HEIGHT CONTROL VALVE SELECTION PROCESS

There are three primary valve manufacturers in North America:

- A. Barksdale
- B. Hadley
- C. Haldex

All three companies make valves that operate in a similar manner so if an exact replacement is desired, it MIGHT be available from your local dealer or distributor. Some “exact replacement” valves are only available from the specific vehicle OEM’s & their dealers. If an exact replacement is not available, several “universal” valves will work in most applications and are shown below. Many of these universal valves also include brackets and arms. The brackets allow the universal valve to be mounted in various manners and the arms will allow for a number of different offsets and arm lengths/mounting to the linkage. Visit MeritorPartsXpress.com or the PB9968 series of suspension catalogs for the complete height control valve offerings.

STEP 3 – OTHER CONSIDERATIONS:

- 1. Arm Length + Offset:** Match the Arm Length and Offset of the OEM Valve for optional performance.
 - While a valve will operate with an arm length that is different than the OEM specification, it will not perform in the optimal manner.
 - The offset may be determined by the bracket and arms which may be flat or bent with an “offset”
 - Some valves have arms that can be removed and replaced. Barksdale valves have arms that are permanently attached and can not be remove or replaced.
- 2. Brackets/mountings:** Are available to allow for the proper mounting of the valve onto the vehicle. In many cases the brackets can be reused.

UNIVERSAL HEIGHT CONTROL VALVES		
Meritor Offers Several Universal Height Control Valves Which Can Be Used In Most Applications		
APPLICATION	MERITOR PART NO.	HADLEY MODEL
No Dump	R3014729	Next Gen
Applied Air To Dump	R3014731	Next Gen
Remove Air To Dump	R3014730	Next Gen

Height control valve definitions

ARM LENGTH

For a valve to function in the optimum manner the arm length must match that of the OE application. Several valves have multiple holes in the arm for attaching the linkage which provides more flexibility and opportunities to match the OE design.

- While a valve will operate with an arm length that is different than the OEM specification, it will not perform in the optimal manner.
- Some valves have arms that can be removed and replaced. Barksdale valves have arms that should not be removed or replaced since this will alter the performance of the valve.

DUMP FEATURE

Dump valves can operate in one of two manners:

- Dump valve opens when pressure is applied to the dump port. In this case the air line to the dump port is typically connected to a button located on the dash board. When activated by the driver, this provides the air pressure necessary to actuate the dump feature in the HCV and dump air to the air springs.
- Dump valve opens when pressure is removed from the dump port. The dump port is on these valves is connected to the air brake system so when the brake pressure is dumped and the spring brakes are set, the dump feature in the HCV is actuated and it dumps air to the air springs.

FITTING TYPES

A number of fitting types are available to provide the connection to the air tubing. 1/4" NPT compression fittings and the newer Push to Connect (PTC) options are the most common. Not every HCV will be available with every fitting type so adapters can be used when necessary to provide the desired connection.

LINKAGE

All HCVs have some type of linkage that attaches the valve arm to the axle. Depending upon the application, the linkage can be a simple straight steel or aluminum shaft with ends which attach to the valve and axle or may be a more complicated design which may be required to avoid interference with nearby components. If the linkage is not damaged and a "like for like" HCV is available, then the linkage can often be reused.

INDEX

- CHALMERS: 800 SERIES** (38–39, 62–63, 85)
- FREIGHTLINER: FAS II AIRLINER®** (6–7, 80)
- FREIGHTLINER: TUFTRAC®** (40–41, 52–53, 83)
- HENDRICKSON: HAULMAAX®** (42–43, 54–55, 85)
- HENDRICKSON: HN®** (44–45, 56–57, 85)
- HENDRICKSON: INTRAAX®** (26–27, 84)
- HENDRICKSON: PRIMAAX®** (64–65, 80)
- HENDRICKSON: RS®** (66–67, 85)
- HENDRICKSON: RT®** (46–47, 83)
- HUTCH: H900** (72–73, 83)
- HUTCH: H7700/9700** (28–29, 82)
- KENWORTH: AIRGLIDE 100** (8–9, 80)
- KENWORTH: AIRGLIDE 200®–400®** (10–11, 80)
- MACK®/VOLVO: CORPORATE AIR** (12–13, 80)
- MACK: SS44 SERIES, CAMELBACK** (48–49, 58–59, 83)
- MERITOR®: MTA** (74–75, 84)
- MERITOR®: RHP/MPA RIDESENTRY** (30–31)
- NAVISTAR/INTERNATIONAL®: CORPORATE AIR** (14–15, 80)
- PETERBILT: AIRGLIDE 210** (20–21, 81)
- PETERBILT: AIR LEAF** (16–17, 81)
- PETERBILT: AIR TRAC** (18–19, 81)
- PETERBILT: FLEX AIR** (22–23, 81)
- REYCO: 21B** (76–77, 82)
- SAF HOLLAND: AD-123 (NEWAY)** (68–69, 81)
- SAF HOLLAND: CBX23/25** (32–33, 84)
- SAF HOLLAND: DURALITE (BINKLEY)** (34–35, 82)

FOR THE COMPLETE SUSPENSION AND COMPONENTS OFFERING,
VISIT MERITORPARTSXPRESS.COM







MERITOR
RUN WITH THE BULL



Vehicle models, trademarks, brands, and names depicted herein are the property of their respective owners, and may not be associated with Meritor, Inc. or its affiliates.



Meritor Heavy Vehicle Systems, LLC
7975 Dixie Highway
Florence, Kentucky 41042 USA
U.S. 888-725-9355
Canada 800-387-3889
MeritorPartsXpress.com
meritor.com

©2020 Meritor, Inc.
Litho in USA, SP-2036
Issued 03-20 (82099)