



**MERITOR®**

an *ArvinMeritor* brand

PB-90199

Revised 11-94

# T-215 and T-2111 Series Transfer Cases

---

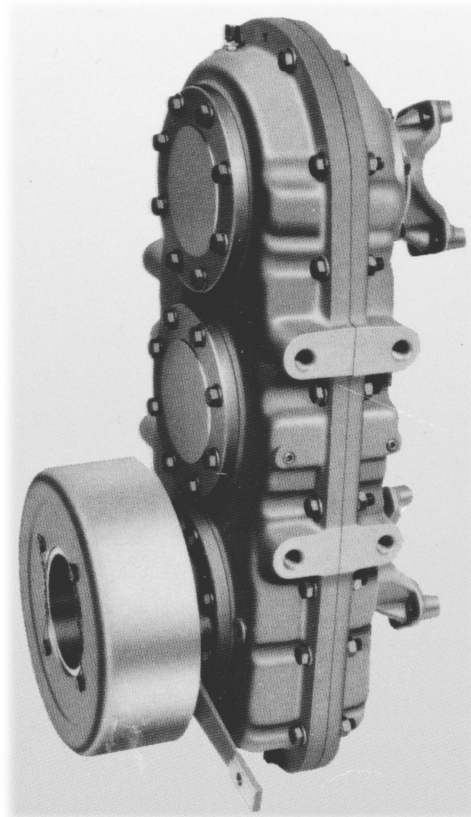

**MERITOR PARTS. RIGHT FROM THE START.**

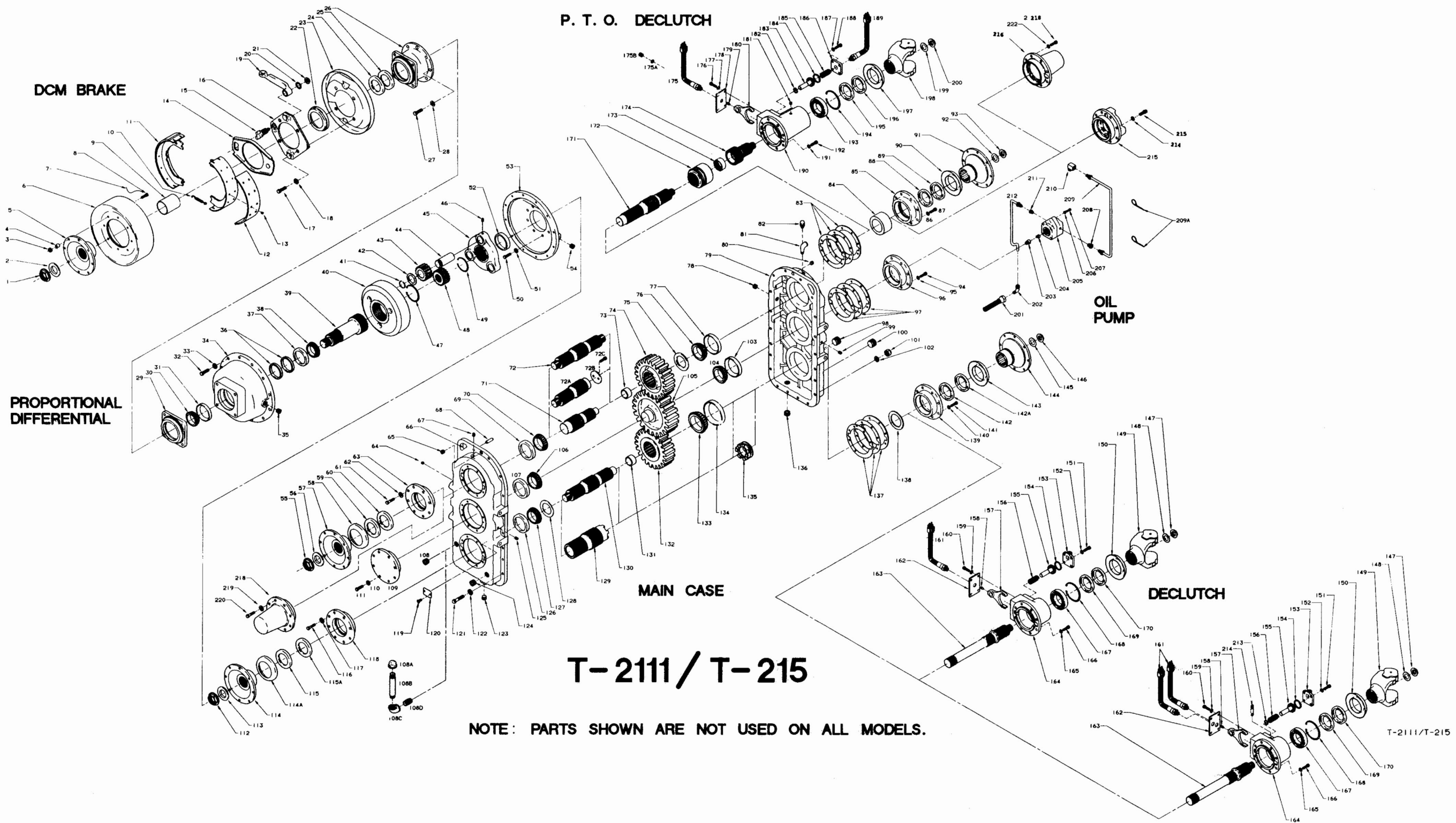

P. T. O. DECLUTCH

DCM BRAKE

PROPORTIONAL DIFFERENTIAL

OIL PUMP

MAIN CASE

DECLUTCH

T-211 / T-215

NOTE: PARTS SHOWN ARE NOT USED ON ALL MODELS.

T-211/T-215

# TABLE OF CONTENTS

	Page
<b>1. T-215/ T-2111 Series Supersessions</b> .....	2
<b>2. T-215/ T-2111 Series Options</b> .....	4
<b>3. T-215/ T-2111 Series Yoke/ Flange and Shaft Reference</b> .....	6
<b>4. T-215/ T-2111 Series Service Kit Reference</b> .....	7
<b>5. T-215 Series Service Kits</b>	
DCM 10" x 3" Non-Asbestos Brake Kit.....	9
DCM 12" x 5" Non-Asbestos Brake Kit.....	9
Main Case Fasteners.....	9
Main Case Shims.....	9
Declutch Miscellaneous Parts.....	10
<b>6. T-2111 Series Service Kits</b>	
DCM 12" x 3" Non-Asbestos Brake Kit.....	11
Proportional Diff. Miscellaneous Parts.....	11
Main Case Fasteners.....	11
Main Case Shims/Bearings.....	11
Declutch & P.T.O. Declutch Fasteners.....	12
<b>7. T-215 Series Transfer Case</b>	
DCM Brake.....	13
Main Case.....	15
5450 lb-ft Declutch/ P.T.O.....	27
<b>8. T-2111 Series Transfer Case</b>	
DCM Brake.....	29
Proportional Differential.....	31
Main Case.....	33
5450 lb-ft Declutch/ P.T.O.....	48
11,000 lb-ft Declutch/ P.T.O.....	52
Oil Pump.....	56
<b>9. Numerical Parts Listing</b> .....	58

# T-215 SERIES SUPERSESSIONS

MODEL	RELEASE DATE	STATUS*	REPLACED BY	REPLACES
T-215-A	May-87	FSO		
T-215-A1	Jul-90	ACT	T-215-T100	
T-215-A2	Jan-90	FSO		
T-215-A5	Jul-93	ACT		
T-215-A6	Jan-93	ACT		
T-215-B	Feb-85	FSO	T-215-B13	
T-215-B1	May-85	FSO	T-215-B11	
T-215-B2	Jul-87	FSO	T215-101	
T-215-B3	Dec-87	FSO	T-215-B12	
T-215-B4	Apr-88	FSO		
T-215-B5	Jun-88	FSO	T-215-B11	
T-215-B6	May-89	FSO	T-215-B9	
T-215-B7	Aug-89	FSO	T-215-B10	
T-215-B8	Oct-89	FSO		
T-215-B9	Oct-89	FSO	T-215-102	T-215-B6
T-215-B10	Oct-89	FSO		T-215-B7
T-215-B11	Nov-89	FSO	T-215-B14	T-215-B1 T-215-B5
T-215-B12	Jan-90	FSO	T-215-100	T-215-B3
T-215-B14	Jan-92	ACT	T-215-B15	T-215-B11
T-215-B15	Jul-92	ACT		
T-215-B16	Nov-92	FSO	T-215-B11	
T-215-101	May-91	ACT		T-215-B2
T-215-102	Jun-91	ACT		T-215-B9
T-215-103	Jul-92	ACT		
T-215-T101	Aug-93	ACT		
T-215-T102	Nov-93	ACT		

\*ACT= Active, bill is completely ready to be sold as is.

FSO= For service only, bill is not to be sold without engineering approval, but all items are serviceable.

# T-2111 SERIES SUPERSESSIONS

MODEL	RELEASE DATE	STATUS*	REPLACED BY	REPLACES
T-2111-D100	Nov-88	FSO	T-2111-D104	
T-2111-D101	Mar-90	OBS	T-2111-D103	
T-2111-D102	May-90	FSO	T-2111-D105	
T-2111-D103	Apr-90	ACT		T-2111-D101
T-2111-D105	Mar-91	ACT		T-2111-D102
T-2111-D106	Mar-91	ACT		
T-2111-D107	Dec-91	ACT		
T-2111-D108	May-91	ACT		
T-2111-D109	Sep-91	ACT		
T-2111-D110	Feb-92	ACT		
T-2111-D111	Jan-94	ACT		
T-2111-D112	Sep-93	ACT		
T-2111-D113	Jun-93	ACT		
T-2111-D116	Jun-94	ACT		
T-2111-D117	Aug-94	ACT		
T-2111-HP100	Feb-94	ACT		
T-2111-PD100	Oct-87	FSO		
T-2111-PD101	Dec-88	FSO	T-2111-PD104	
T-2111-PD102	Sep-89	FSO	T-2111-PD103	
T-2111-PD103	Feb-91	ACT		T-2111-PD102
T-2111-PD104	Feb-91	ACT		T-2111-PD101
T-2111-PD106	Jan-94	ACT		
T-2111-T100	Feb-90	FSO		
T-2111-T101	Feb-90	FSO	T-2111-T-102	
T-2111-T102	Apr-91	ACT		T-2111-T-101
T-2111-T103	Dec-91	ACT		
T-2111-T104	Jan-92	ACT		
T-2111-T105	Jan-93	ACT		
T-2111-T106	Jun-94	ACT		
T-2111-T107	Aug-93	ACT		
T-2111-T108	Dec-93	ACT		

\*ACT= Active, bill is completely ready to be sold as is.

FSO= For service only, bill is not to be sold without engineering approval, but all items are servicable.

OBS= Obsolete, bill is not to be sold for new orders. Check with Meritor's service department for availability of service parts.

# T-215 SERIES OPTIONS

MODEL	DECLUTCH/ P.T.O.	DCM** BRAKE	THRU SHAFT	OIL PUMP	FLANGE/YOKE			
					FRONT INPUT	REAR INPUT	FRONT OUTPUT	REAR OUTPUT
T-215-A	X		X		X	X	X	
T-215-A1	X*				X	X	X	
T-215-A2			X		X		X	X
T-215-A3	X				X		X	X
T-215-A5	X				X		X	
T-215-A6	X				X		X	
T-215-B		10" X 3"			X		X	
T-215-B1		12" X 5"			X		X	
T-215-B2					X		X	
T-215-B3								
T-215-B4					X		X	
T-215-B5		12" X 5"			X		X	
T-215-B6					X		X	
T-215-B7							X	
T-215-B8		12" X 5"			X		X	
T-215-B9					X		X	
T-215-B10							X	
T-215-B11		12" X 5"			X		X	
T-215-B12								
T-215-B14		12" X 5"			X		X	
T-215-B15		12" X 5"			X		X	
T-215-B16		12" X 5"			X		X	
T-215-101					X		X	
T-215-102					X		X	
T-215-103					X		X	
T-215-T101	X				X		X	
T-215-T102					X		X	

\*T-215-A1 has two declutches.

\*\*Brake may be used as input/output attachment.

# T-2111 SERIES OPTIONS

MODEL	DECLUTCH/ P.T.O.	DCM** BRAKE	THRU SHAFT	PROP. DIFF. W/ LOCKUP	OIL PUMP	FLANGE/YOKE			
						FRONT INPUT	REAR INPUT	FRONT OUTPUT	REAR OUTPUT
T-2111-D100	X						X	X	X
T-2111-D101	X*					X	X	X	
T-2111-D102	X					X		X	X
T-2111-D103	X*				X	X	X	X	
T-2111-D105	X					X		X	X
T-2111-D106	X					X		X	X
T-2111-D107	X***				X	X		X	X
T-2111-D108	X***				X	X		X	X
T-2111-D109	X					X		X	X
T-2111-D110	X*				X	X		X	X
T-2111-D111	X					X		X	X
T-2111-D112	X					X		X	
T-2111-D113	X					X			X
T-2111-D116	X					X		X	
T-2111-D117	X					X			X
T-2111-HP100	X				X	X		X	
T-2111-PD100		12" X 3"		X			X	X	X
T-2111-PD101				X			X	X	X
T-2111-PD102				X		X		X	X
T-2111-PD103				X		X		X	X
T-2111-PD104				X			X		X
T-2111-PD106	X					X		X	
T-2111-T100	X		X			X	X	X	
T-2111-T101	X		X			X	X	X	
T-2111-T105	X					X		X	
T-2111-T106	X		X		X	X		X	
T-2111-T107	X					X		X	
T-2111-T108					X	X		X	

\*T-2111-D101, T-2111-D103 and D110 have two P.T.O. declutches.

\*\*Brake may be used as input/output attachment.

\*\*\*T-2111-D107 and T-2111-D108 have three declutch/PTO assy.

# T-215 & T-2111 SERIES

## YOKE/FLANGE AND SHAFT REFERENCE

INSTRUCTIONS FOR USE- To match available Yoke/Flanges with a known shaft, find the shaft in the shaft spline guide in the upper left hand corner of this sheet. Note the yoke spline group and then use the yoke identification chart. If you already have the information then use the yoke identification chart.

### SHAFT SPLINE GUIDE

SHAFT PART NUMBER	SPLINE CODE
3297-N-1002	A
3297-P-1004	A, B, C
3297-U-1035	D
A-3297-W-1037	D
3297-B-1042	D
3297-F-1046	D
3297-J-1050	D
3297-K-1051	D
3297-Z-1144	D
3297-K-1155	F
A-3297-R-1162	E
3297-W-1167	E
3297-A-1171	D
A-3297-B-1172	D
3297-F-1202	E
3297-J-1206	D
3297-K-1207	C

### YOKE IDENTIFICATION

SPLINE SIZE DIA-TEETH (GROUP)	SPLINE LENGTH	SERIES	PRODUCTION PART NUMBER	SERVICE PART NUMBER
1.75"- 10 SPLINE <b>(A)</b>	2.25"	148NYS	A-3280-U-2205	148NYS28A
		155NYS	A-3280-J-2454	--
2.00"-10 SPLINE <b>(B)</b>	2.25"	3WCS	3280-Y-8267	3WCS22-79 (1)
2.00"- 10 SPLINE <b>(C)</b>	3.00"	SPECIAL	3260-X-1038	--
		5WCS	3897-N-1990	5WCS32-50
		155TYS	A-3260-Z-1378	155TYS32-23A
		17 NYS	A-3260-Y-1039	17NYS32-63A
2.13"- 41 SPLINE <b>(D)</b>	2.13"	85WB	A-3260-A-79	85WBY34-4
		5WCS	3260-R-1344	5WCS34-8
		5WCS	3280-U-7535	5WCS34-7
		17 NYS	A-3260-T-1294	17NYS34-20A
		17 TYS	A-3260-C-1407	17TYS34-38A
		18 TYS	A-3260-D-1408	18TYS34-4A
		18 NYS	A-3260-S-1449	18NYS34-4A
		155TYS	A-3260-X-1454	155TYS34-6A
		148TYS	3260-G-1515	148TYS34-3
		5WCS	3260-B-1458	5WCS33-3
		5WCS	3260-C-1511	5WCS34-9
17 NYS	A-3260-D-1460	17NYS34-29A		
155TYS	3260-B-1510	155TYS34-7		
18 NYS	A-3260-D-1512	18NYS34-5A		
2.29"- 44 SPLINE <b>(F)</b>	2.80"	17 TYS	A-3260-P-1420	17TYS36-59A
		18 TYS	A-3260-Q-1421	18TYS36-17A
		72N	A-3260-U-1425	72NYS36-97A
		82N	A-3260-V-1426	82NYS36-124A

(1) MUST USE 1244-S-1761 SPACER



## T-215 SERIES SERVICE KIT REFERENCE

MODEL	KIT T215-1	KIT T215-2	KIT T215-3	KIT T215-4	KIT T215-5
T-215-A			X	X	X
T-215-A1			X	X	X#1
T-215-A2			X	X	
T-215-A3			X	X	X
T-215-A5			X	X	X
T-215-A6			X	X	X
T-215-B	10" X 3"		X	X	
T-215-B1		12" X 5"	X	X	
T-215-B2			X	X	
T-215-B3			X	X	
T-215-B4			X	X	
T-215-B5		12" X 5"	X	X	
T-215-B6			X	X	
T-215-B7			X	X	
T-215-B8		12" X 5"	X	X	
T-215-B9			X	X	
T-215-B9			X	X	
T-215-B10			X	X	
T-215-B11		12" X 5"	X	X	
T-215-B12			X	X	
T-215-B14		12" X 5"	X	X	
T-215-B15					
T-215-B16		12" X 5"	X	X	
T-215-101			X	X	
T-215-102			X	X	
T-215-103			X	X	
T-215-T101			X	X	X
T-215-T102			X	X	

#1 Kit T-215-5 services one (1) declutch. Model T-215-A1 has two (2) declutches.

## T-2111 SERIES SERVICE KIT REFERENCE

MODEL	KIT T2111-1	KIT T-2111-2	KIT T-2111-3	KIT T-2111-4	KIT T-2111-5
T-2111-D100			X	X	X
T-2111-D101			X	X	X#1
T-2111-D102			X	X	X
T-2111-D103			X	X	X#1
T-2111-D105			X	X	X
T-2111-D106			X	X	X
T-2111-D107			X	X	X#2
T-2111-D108			X	X	X#2
T-2111-D109			X	X	X
T-2111-D110			X	X	X#1
T-2111-D111			X	X	X
T-2111-D112			X	X	X
T-2111-D113			X	X	X
T-2111-D116			X	X	X
T-2111-D117			X	X	X
T-2111-PD100	12" X 3"	X	X	X	X
T-2111-PD101		X	X	X	X
T-2111-PD102		X	X	X	X
T-2111-PD103		X	X	X	X
T-2111-PD104		X	X	X	X
T-2111-PD106			X	X	X
T-2111-T100			X	X	X
T-2111-T101			X	X	X
T-2111-T105			X	X	X
T-2111-T106			X	X	X
T-2111-T107			X	X	X
T-2111-T108			X	X	

#1 Kit T-2111-5 services one (1) P.T.O. declutch. Model T-2111-D101, D103 and D110 each have two (2) P.T.O. declutches.

#2 Kit T-2111-5 services one (1) P.T.O. declutch. Model T-2111-D107 and D108 each have three (3) P.T.O. declutches.

# T-215 SERIES SERVICE KITS

## KIT T-215-1

## DCM 10" X 3" NON-ASBESTOS BRAKE KIT

PART NAME	PART NUMBER	QTY	ITEM NUMBER ON EXPLODED VIEW
Brake Shoe and Lining Assy.*	A2-3722-G-501	2	11
Spring-brake shoe return	2758-A-53	4	10
Lockwire-brake drum to hub	LW-168	2	7
Capscrew-brake drum to hub	S-166-D1	4	8
Capscrew-brake to brg. cage	3X-374	4	17
Oil Seal-brake brg. cage	A-1805-P-536	1	24
Capscrew-brake brg. cage	S-2710-2	8	27
Washer-brake brg. cage capscrew	1229-E-1513	8	28

\* Lining and rivets available separately in Kit 2000-J-1362.

## KIT T-215-2

## DCM 12" X 5" NON-ASBESTOS BRAKE KIT

PART NAME	PART NUMBER	QTY	ITEM NUMBER ON EXPLODED VIEW
Brake Shoe and Lining Assy.*	A2-3722-F-422	2	11
Spring-brake shoe return	2758-A-53	4	10
Nut-brake drum to flange	N-16-1	8	3
Washer-brake drum to flange	1229-K-1597	8	4
Bolt-brake drum to flange	10X-507	8	8
Capscrew-brake brg. cage	S-21012-2	4	17
Oil Seal-brake brg. cage	A-1205-S-2281	1	24
Capscrew-brake brg. cage	S-2710-2	8	27
Washer-brake brg. cage capscrew	1229-E-1513	8	28

\* Lining and rivets available separately in Kit 2000-A-1457.

## KIT T-215-3

## MAIN CASE FASTENERS

PART NAME	PART NUMBER	QTY	ITEM NUMBER ON EXPLODED VIEW
Capscrew-rear input shaft brg. cage, front input shaft brg. cage, front idler gear brg. cage, rear idler gear brg. cage, rear output shaft brg. cage.	S-2710-2	48	61, 87, 94, 111, 116, 141
Washer-rear input shaft brg. cage, front input shaft brg. cage, front idler gear brg. cage, rear idler gear brg. cage, rear output shaft brg. cage, transfer case capscrew	1229-E-1513	88	62, 86, 95, 102, 110, 117, 122, 140
Nut-transfer case capscrew lock	NL-27-1	20	101
Capscrew-transfer case	S-2718-1	20	121
Dowel-transfer case	1846-Z-312	2	68

## KIT T-215-4

## MAIN CASE SHIMS

PART NAME	PART NUMBER	QTY	ITEM NUMBER ON EXPLODED VIEW
Shim-input shaft, idler shaft and output shaft (0.003")	2203-F-8872	9	83, 97, 137
Shim-input shaft, idler shaft and output shaft (0.005")	2203-E-8871	9	83, 97, 137
Shim-input shaft, idler shaft and output shaft (0.010")	2203-D-8870	21	83, 97, 137

# T-215 SERIES SERVICE KITS

## KIT T-215-5\*

## DECLUTCH MISCELLANEOUS PARTS

<b>PART NAME</b>	<b>PART NUMBER</b>	<b>QTY</b>	<b>ITEM NUMBER ON EXPLODED VIEW</b>
Capscrew-declutch shift cover	S-268-2	4	151
Capscrew-declutch plate	S-269-1	4	160
Washer-declutch shift cover, declutch plate	1229-K-1597	8	152, 159
Capscrew-declutch brg. cage	S-2710-2	8	166
Washer-declutch cage capscrew	1229-E-1513	8	165
Bearing-declutch shaft ball	1228-V-204	1	167
Oil Seal Assy.-declutch cage	A-1205-U-1529	1	169
Oil Seal Assy.-declutch cage	A-1205-A-2107	2	170

\* Kit T-215-5 services one (1) declutch. Some models have two (2) declutches.

# T-2111 SERIES SERVICE KITS

## KIT T-2111-1

## DCM 12" X 3" NON-ASBESTOS BRAKE KIT

PART NAME	PART NUMBER	QTY	ITEM NUMBER ON EXPLODED VIEW
Brake Shoe and Lining Assy.*	A2-3722-D-420	2	11
Spring-brake shoe return	2758-A-53	4	10
Nut-brake drum to flange	N-16-1	8	3
Spacer-brake drum to flange	1844-U-411	8	4
Bolt-brake drum to hub	10X-507	8	8
Capscrew-cover adapter to cage	10X-1438	4	17

\* Lining and rivets available separately in Kit 2000-P-1446.

## KIT T-2111-2

## PROPORTIONAL DIFF. MISC. PARTS

PART NAME	PART NUMBER	QTY	ITEM NUMBER ON EXPLODED VIEW
Cone-proportional diff. cage shaft	390	2	30, 38
Cup-proportional diff. cage shaft	394A	2	31, 37
Capscrew-diff. cage to gear case cover	S-2710-2	20	32, 50
Washer-diff. cage to gear case cover	1229-E-1513	20	33, 51
Shim-proportional diff. cage brg. spacer (0.478")	2203-W-9851	2	36
Shim-proportional diff. cage brg. spacer (0.482")	2203-X-9852	2	36
Shim-proportional diff. cage brg. spacer (0.490")	2203-Y-9853	2	36
Shim-proportional diff. cage brg. spacer (0.498")	2203-Z-9854	2	36
Shim-proportional diff. cage brg. spacer (0.506")	2203-A-9855	2	36
Shim-proportional diff. cage brg. spacer (0.510")	2203-B-9856	2	36
Snap Ring-planet. pinion shaft	1854-Z-182	3	41
Washer-planet. pinion thrust	1229-F-2814	3	42
Setscrew-planet. pinion shaft	26X-237	3	46
Snap Ring-outer rear output shaft	1854-S-149	2	47, 49

## KIT T-2111-3

## MAIN CASE FASTENERS

PART NAME	PART NUMBER	QTY	ITEM NUMBER ON EXPLODED VIEW
Capscrew-rear input shaft brg. cage, front input shaft brg. cage, rear idler gear brg. cage, front output shaft brg. cage.	S-2710-2	32	61, 87, 94, 111
Washer-brg. cage, transfer case capscrew	1229-E-1513	72	62, 86, 95, 102, 110, 122
Nut-transfer case capscrew lock	NL-27-1	20	101
Capscrew-transfer case	S-2718-1	20	121
Dowel-transfer case	1846-Z-312	2	68

## KIT T-2111-4

## MAIN CASE SHIMS/BEARINGS

PART NAME	PART NUMBER	QTY	ITEM NUMBER ON EXPLODED VIEW
Shim-input shaft, idler shaft, output shaft (0.010")	2203-D-8870	21	83, 97, 137
Shim-input shaft, idler shaft, output shaft (0.005")	2203-E-8871	9	83, 97, 137
Shim-input shaft, idler shaft, output shaft (0.003")	2203-F-8872	9	83, 97, 137
Cup-front idler gear brg., rear idler gear brg.	45220	4	69, 77, 103, 107
Cone-front idler gear brg., rear idler gear brg.	45290	4	70, 76, 104, 106
Cone-output shaft front brg.	45687	1	127
Cup-output shaft front brg.	42620	1	126

# T-2111 SERIES SERVICE KITS

## KIT T-2111-5\*

## DECLUTCH/ P.T.O. DECLUTCH FASTENERS

<b>PART NAME</b>	<b>PART NUMBER</b>	<b>QTY</b>	<b>ITEM NUMBER ON EXPLODED VIEW</b>
Capscrew-declutch shift cover	S-268-2	4	151
Washer-shift cover capscrew, declutch plate capscrew	1229-K-1597	8	152, 159
Capscrew-declutch brg. cage	S-2710-2	8	166
Washer-declutch cage capscrew	1229-E-1513	8	165
Capscrew-declutch plate	S-265-1	4	160
Capscrew-declutch plate	S-266-1	4	176

\* Kit T-2111-5 services one (1) declutch. Some models have two (2) or three (3) declutches.

## T-215 SERIES DCM BRAKES

ITEM	PART NAME	MODEL	QTY	PART NUMBER	DESCRIPTION
1	Locknut-brake	B, B1, B5, B8, B11	1	1227-Z-936	1.25"- 18, 0.63" high, 1.63" across flats.
2	Washer-brake	B, B1, B5, B8, B11	1	1229-K-2143	2.56" O.D., 1.28" I.D., 0.19" thick.
3	Nut-brake drum to flange	B1, B5, B8, B11	8	N-16-1	0.38"- 24, 0.56" across flats, grade 8.
4	Washer-brake drum to flange	B1, B5, B8, B11	8	1229-K-1597	0.75" O.D., 0.41" I.D., 0.09" thick.
5	Flange-brake drum	B	1	3280-Y-8267	3 WCS flange, 3897-Q-3007 forging, 10T internal spline with 1.82" minor diameter, 4 holes 0.38"- 24 on 5.75" bolt circle diameter, 4.34" end hub to flange mounting face.
		B1, B5, B8, B11	1	3280-X-1038	Flange, 3260-Q-1291 forging, 10T internal spline with 1.82" minor diameter, 8 holes 0.38" diameter on 7.25" bolt circle diameter, 6.13" end hub to flange mounting face.
6	Drum-brake	B	1	3819-E-525	3719-S-227 stamping, 10.0" I.D., 4.75" pilot diameter, 4 mounting holes 0.39" diameter on 5.75" bolt circle diameter.
		B1, B5, B8, B11	1	3219-K-4743	3819-P-510 casting, 14.0" O.D., 5.81" wide, 1.44" long squealer band, 8 mounting holes on 7.25" bolt circle diameter.
7	Lockwire-brake drum to hub capscrew	B	2	LW-168	16 gage, 8.0" long.
8	Capscrew-brake drum to hub	B	4	S-166-D1	0.38"- 24, 0.75" long, 1 hole drilled in head, 0.56" across flats, grade 8.
	Bolt-brake drum to flange	B1, B5, B8, B11	8	10X-507C	0.38"- 24, 1.75" long, 27 serrations on bolt body, 0.56" across flats.
9	Spacer-brake hub	B	1	1244-S-1761	2.31" O.D., 2.07" I.D., 0.75" long.
10	Spring-brake shoe return	B, B1, B5, B8, B11	4	2758-A-53	11 coils, 0.75" in diameter, 2.75" long.
11	Brake Shoe and Lining Assy.	B	2	A2-3722-G-501	10" x 3", non-asbestos, replaces A1-3772-G-501, asbestos, includes items 12 (J-1362) and 13 (RV-875).
		B1, B5, B8, B11	2	A2-3722-F-422	12" x 5", non-asbestos, replaces A1-3772-F-422, asbestos, includes items 12 (N-5162) and 13 (RV-876).
12	Lining-brake	B	2	2000-J-1362	Included in item 11, lining and rivets (RV-875) available as kit only.
		B1, B5, B8, B11	2	2240-N-5162	Included in item 11, lining and rivets (RV-876) sold separately or in Kit 2000-A-1457.
13	Rivet-lining to shoe	B	28	RV-875	Included in item 11, lining and rivets sold separately or in Kit 2000-J-1362.
		B1, B5, B8, B11	26	RV-876	Included in item 11, lining and rivets sold separately or in Kit 2000-A-1457.
14	Strut Assy.	B	1	A-3787-Q-17	9.13" long, 4.88" diameter bore.
		B1, B5, B8, B11	1	A-3787-N-14	10.75" long, 5.4" diameter bore.

## T-215 SERIES DCM BRAKES

ITEM	PART NAME	MODEL	QTY	PART NUMBER	DESCRIPTION
15	Camshaft	B, B1, B5, B8, B11, B14	1	2710-U-151	2710-X-154 forging, 3.17" long, 32 serrations 1 end, 0.56"-12 thread 1 end.
16	Backing Plate Assy.	B	1	A-3736-D-472	4.19" I.D., pilot, 4 holes 0.54" diameter, includes anchor pin 1759-G-59 (2 pieces).
		B1, B5, B8, B11, B14		A-3736-K-375	5.50" I.D. pilot, 4 holes 0.67" diameter, includes anchor pin 1759-G-59 (2 pieces).
17	Capscrew-brake to bearing cage	B	4	S-289A-1	0.50"-13, 1.13" long with loctite patch.
		B1, B5, B8, B11, B14, B15, B16	4	S-21012-2	0.63"-11, 1.50" long. 0.93" across flats, grade 8, replaces 10X-803, (0.63"-18. 2.00" long).
18	Washer-brake to bearing cage	-	4	1229-U-1503	Not used on T-215 models in this book.
19	Lever-brake	B	1	372-X-206	372-W-205 cast, 5.25" dimension from 0.44" diameter cable hole to 1.00" bore.
		B1, B5, B11, B14	1	372-E-213	372-D-212 cast, 7.13" center bore to 0.56" diameter cable hole.
		B8	1	2247-M-1157	372-D-212 cast, 6.25" from center of 1.00" bore to 0.50" diameter cable hole, had 32 serrations on bore I.D.
20	Washer-brake	B, B1, B5, B8, B11, B14	1	WA-39	1.19" O.D., 0.59" I.D., 0.09" thick.
21	Nut-lock	B, B1, B5, B8, B11, B14	4	1779-Z-260	0.56"-12, 1.00" across flats.
22	Deflector-brake adapter	-	1	2297-C-627	Not used on T-215 models in this book.
23	Dust shield	-	1	3264-V-100	Not used on T-215 models in this book.
24	Oil Seal-brake bearing cage	B	1	A-1805-P-536	3.50" O.D., 2.63" shaft, 0.50" wide, double lip, double case with spring.
		B1, B5, B8, B11, B14, B15, B16	1	A-1205-S-2281	3.55" O.D., 2.75" shaft, 0.47" wide, double lip, double case with spring, replaces A-1805-D-212, (double lip, single case with spring).
25	Oil Seal-brake bearing cage	-	1	A-1205-A-2107	Not used on T-215 models in this book.
26	Cage Assy.-brake bearing	B	1	A-3226-F-1046	3226-E-1045 casting, 4 holes 0.50"-13 on 5.13" bolt circle diameter, 8 holes 0.47" diameter on 6.00" bolt circle diameter, 4.13" overall length, includes item 69 (3720).
		B1, B5	1	3226-H-1048	3226-G-1047 casting, 5.02" overall length, 3.67" bore, 8 holes 0.47" diameter on 6.00" bolt circle diameter, 4 holes 0.63"-11 on 6.69" bolt circle diameter, with brake adapter, includes item 69 (3720).
		B8, B11, B14, B16	1	A-3226-E-1201	Same as H-1048 except 4.12" bearing bore includes item 69 (45220).
27	Capscrew-brake bearing cage	B, B1, B5, B8, B11, B14, B16	8	S-2710-2	0.44"-14, 1.25" long, 0.62" across flats, grade 8.
28	Washer-brake bearing cage capscrew	B, B1, B5, B8, B11, B14, B15, B16	8	1229-E-1513	0.81" O.D., 0.47" I.D., 0.09" thick.

\*\*Note: T-215 has no proportional differential.



## T-215 SERIES MAIN CASE

ITEM	PART NAME	MODEL	QTY	PART NUMBER	DESCRIPTION
55	Nut-input shaft	A, A1, A3, B16, 101, 102	1	1227-K-1051	1.25"-12, 0.63" high, 1.63" across flats.
		A2, B, B2, B3, B4, B6, B7, B9, B10, 12	1	1227-Z-936	1.25"-18, 0.63" high, 1.63" across flats.
56	Washer-input shaft	A, A1, A3, 101, 102	1	1229-T-1450	2.56" O.D., 1.28" I.D., 0.23" thick.
		A2, B, B2, B3, B4, B6, B7, B9, B10, B12	1	1229-K-2143	2.56" O.D., 1.28" I.D., 0.19" thick.
57	Flange/Yoke-input shaft	A, 101	1	17NYS34-20	17 NYS yoke, 2.13"-41T internal spline, 5.16" end hub to center cross assy.
		A1, 102 T101	1	A-3260-X-1454	155TYS yoke, 2.13"-41T spline, 4 holes 0.38" diameter in ears, 4.50" end hub to center cross assy, includes items 58 (K-6303).
		A3	1	3260-X-1454	155TYS, 2.13"-41T spline, 4 holes 0.38" diameter in ears, 4.50" end hub to center cross assy.
		B	1	A-3280-U-2205	148TYS yoke, 1.75"-10T spline, 4.31" long end hub to center cross assy, has 4 holes 0.46" diameter in ears, includes item 58 (C-627).
		A2, B2, B16	1	A-3260-Y-1039	17NYS yoke, 1.75"-10T spline, 4.81" end hub to center cross assy, includes item 58 (Z-312).
		B4	1	A2-3280-J-2454	148TYS yoke, 1.75"-10T spline, 4 holes 0.46" diameter in ears, 4.31" long end hub to center cross assy, includes item 58 (C-367).
		B6, B9	1	A-3260-Z-1378	155TYS yoke, 2.00"-10T spline, 4 holes 0.38" diameter in ears, includes item 58 (Z-312).
		A6	1	A-3260-U-1633	16TYS yoke, 2.13"-41T spline, 4 holes 0.38" diameter in ears, 2.94" end hub to center cross assy.
		T102	1	A-3260-A-79	85 WBYS yoke, 2.30"-41T spline, 4 holes 0.50" in ears, 2.90" end hub to center cross assy.
		58	Deflector-input shaft	A1	1
B	1			2297-C-627	5.13" O.D., 0.69" wide, included in item 57 (U-2205).
B2, B6, B9 B16	1			2847-Z-312	4.81" O.D., 0.81" wide, included in item 57 (Y-1039 and Z-1378).
B4	1			2847-C-367	4.75" O.D., 0.81" wide, included in item 57 (J-2454).
59	Oil Seal-input shaft brg. cage	A, A1, A2, A3, A5, A6, B2, B3, B6, B9, B16, 101, 102, 103, T101, T102	1	A-1205-U-1529	4.00" O.D., 2.94" shaft, 0.45" wide, double lip, double case with spring, replaces A-1805-A-261, 2.75" I.D.

(Continued)

## T-215 SERIES MAIN CASE

ITEM	PART NAME	MODEL	QTY	PART NUMBER	DESCRIPTION
59	Oil Seal-input shaft brg. cage	B, B4	1	A-1805-A-261	4.00" O.D., 2.75" shaft, 0.45" wide, double lip, double case with spring.
		B7, B10, B12	1	A-1205-S-2281	3.55" O.D., 2.75" shaft. 0.47" wide, double lip, double case with spring, replaces A-1805-D-212, (double lip, single case with spring).
60	Oil Seal-input shaft brg. cage	A3, A5, A6, 101, 102, 103, T101, T102	1	A-1205-A-2107	4.00" O.D., 3.00" shaft, 0.25" side, single lip, full case.
61	Capscrew-input shaft brg. cage	All	8	S-2710-2	0.44"-14, 1.25" long, 0.62" across flats, grade 8.
62	Washer-input shaft brg. cage	All	8	1229-E-1513	0.81" O.D., 0.47" I.D., 0.09" thick.
63	Cage Assy.-input shaft bearing	A	1	A-3226-X-1142	3226-P-1238 casting, 8 holes 0.47" diameter on 6.00" bolt circle, 4.12" bore, 1.79" overall length, includes item 69 (45220).
		B, B1, B2, B3, B4, B5, B6, B7	1	A-3226-K-1051	3226-J-1050 casting, 1.73" overall length, 8 holes 0.47" diameter on 6.00" bolt circle 3.67" bore, includes item 69 (3720).
		A2, A5, A6, B8, B9, B10, B11, B12, B16, 103, 103, T101, T102	1	A-3226-F-1280	3266-U-1139 casting, 8 holes 0.47" diameter on 6.00" bolt circle, 4.12" bore, 1.73" overall length, includes item 69 (45220).
		A3, A5, B15, B16, 101, 102, 103, T102	1	A-3226-G-1255	3226-P-1238 casting. 2.12" overall length, 8 holes 0.47" diameter on 6.00" bolt circle, includes item 69 (45220).
64	Plug-transfer case	All	1	P-42	Hex socket-female, 0.13"-27 N.P.T.F. thread, 0.27" long, non-magnetic.
65	Plug-transfer case	102, 103	1	P-26	Square socket, 0.38"-16 P.T.F. thread 0.41" long, non-magnetic.
66	Case-transfer	All	1	3290-M-1001	26.50" long x 11.40" wide.
67	Plug-transfer case	All	1	P-42	Hex socket-female, 0.13"-27 N.P.T.F. thread, 0.27" long, non-magnetic.
68	Dowel-transfer case	All	2	1846-Z-312	0.38" diameter, 1.00" long.
69	Cup-input shaft bearing	A, A2, A3, A5, A6, B8, B9, B10, B11, B12, B14, B15, B16, 101, 102, T101, T102	1	45220	4.13" O.D., included in item 63 (X-1142, F-1280, and G-1255) and item 26 (E-1201).
		A1, A5	1	42620	5.00" O.D.
		B, B1, B2, B3, B4, B5, B6, B7	1	3720	3.67" O.D., included in item 63 (K-1051).
70	Cone-input shaft bearing	A, A3, A5, 101, 102, T101, T102	1	45290	2.25" bore.
		A1, A5	1	42687	3.00" bore.
		B, B1, B2, B3, B4, B5, B6, B7	1	3780	2.00" bore.
		A2, B8, B9, B10, B11, B12, B14, B16	1	45285	2.00"bore.

## T-215 SERIES MAIN CASE

ITEM	PART NAME	MODEL	QTY	PART NUMBER	DESCRIPTION
71	Shaft-input	A1, A5, A6	1	A-3297-B-1172	8.86" long, 1 spline 2.13"-41T, 1 spline 3.37"-26, 6T dog clutch one end, 1.25"-12 thread one end, includes item 73.
		B, B4	1	3297-N-1002	7.88" long, 1 spline 1.75"-10T, 1 spline 2.50"-10T, 1.25"-18 thread 1 end.
		A2, B1, B2, B3, B5, B6, B7, B8, B9, B10, B11	1	3297-Z-1144	8.50" long, 1 spline 2.00"-10T, 1 spline 2.51"-10T, 1.25"-18 thread 1 end only.
		A3, A5, A6, 101, 102, T102	1	3297-J-1206	8.15" long, 1 spline 2.13"-41T, 2.38" long, 1 spline 2.65"-52T, 2.24" long and 1.25"-12 thread one end.
		B14	1	3297-K-1207	8.75" long, 1 spline 2.00"-10T, 3.00" long, 1 spline 2.65"-52T, 2.24" long and 1.25"-12 thread one end.
		B15	1	3297-K-1285	8.60" long, 1 spline 2.00" -10T, 1 spline 2.65"-52T, 2 holes 0.38"-16 on 1.06" on bolt circle.
		B16	1	3297-L-1286	8.35" long, 1 spline 2.00" -10T, 1 spline 2.50"-10T, 2 holes 0.38"-16 on 1.06" bolt circle.
72	Shaft-input	A, T101, T102	1	3297-B-1042	11.56" long, 2 splines 2.13"-41T, 1 spline 2.65"-52T, and 1.25"-12 thread on both sides.
72A	Shaft-input	103	1	3297-G-1281	8.00" long, 2 splines, 1 spline 2.13"-41T, 1 spline 2.65"-52T, and 1.25"-12 thread one end.
72B	Washer-shaft input	B16, 103	1	1229-F-4582	2.62" O.D., 1.06" I.D., 2 holes 0.41" thru diameter, 0.16" thick.
72C	Capscrew-shaft input	B16, 103	2	S-268-1	0.38"-16, 1.00" long, 0.56" across flats, grade 8.
73	Bearing-input	A2, A5, A6, B1, B2, B3, B5, B6, B7, B8, B9, B10, B11	1	1228-A-53	Needle roller bearing, 1.88" O.D., 1.25" wide included in item 71, (B-1172).
74	Gear-input shaft	A, A3, A5, A6, B14, B15, 101, 102, 103, T101, T102	1	3892-C-4995	3892-A-4837 forging, 31T, R.H. helical, 7.18" O.D., 2.56" major diameter- 52T spline.
		A1	1	3892-B-4994	3892-A-4837 forging, 31T, R.H. helical, 7.18" O.D., 3.13" major diameter- 26T, spline.
		All others	1	3892-B-4838	3892-A-4837 forging, 31T, R.H. helical, 7.18" O.D., 2.50" major diameter- 10T, spline.
75	Spacer-input shaft	-	1	1244-U-1789	Not used on T-215 models in this book.
76	Cone-input shaft bearing	A, A1, A3, A5, A6, 101, 102, 103, T101, T102	1	45290	2.25" bore.
		B, B1, B2, B3, B4, B5, B6, B7	1	3780	2.00" bore.

(Continued)

## T-215 SERIES MAIN CASE

ITEM	PART NAME	MODEL	QTY	PART NUMBER	DESCRIPTION
76	Cone-input shaft bearing	A2, B8, B9, B10, B11, B12 B14, B15, B16	1	45285	2.00" bore.
77	Cup-input shaft bearing	A, A1, A2, A3, A5, A6, B8, B9, B10, B11, B12, B14, B15, B16, 101, 102, T101, T102	1	45220	4.13" O.D., included in item 85 (X-1142, F-1280, E-1201, and H-1230).
		B, B1, B2, B3, B4, B5, B6, B7	1	3720	3.67" O.D., included in item 85 (Z-1040 and H-1048).
78	Plug-transfer case	All	1	P-42	Hex socket-female, 0.13"-27 N.P.T.F. thread, 0.27" long, non-magnetic.
79	Case-transfer	All	1	3290-M-1001	26.5" long x 11.40" wide.
80	Plug-transfer case	102, 103	1	P-26	Square socket, 0.38"-16 P.T.F. thread, 0.41" long, non-magnetic.
81	Elbow-oil breather	A1	1	1898-H-216	Male end 1.00" long, female end 0.69" long, 0.13"-27 N.P.T.F. both ends.
82	Breather-transfer case	All	1	A-1199-C-1043	1.06" long with 0.13"-27 N.P.S.F., replaces A-1199-J-166 (1.00" long).
83	Shim-input shaft	All	3	2203-F-8872	0.003", use as required, 7.00" O.D., 5.06" I.D., 8 holes 0.47" diameter on 6.00" bolt diameter, 2 notches 0.80" wide on I.D., equal spaced.
			3	2203-E-8871	Same as F-8872 except thickness 0.005" use as required.
			7	2203-D-8870	Same as F-8872 except thickness 0.010" use as required.
84	Spacer-input shaft	A1, A5, A6	1	1244-N-2042	4.00" O.D., 2.31" I.D., 0.19" thick.
		B, B4	1	1244-R-1760	2.31" O.D., 1.81" I.D., 0.13" thick.
85	Cage Assy.-input shaft bearing	A, A2, B9	1	A-3226-X-1142	3226-P-1238 casting, 8 holes 0.47" diameter on 6.00" bolt circle, 4.12" bore, 1.79" overall length, includes item 77 (45220).
		A1, A5, A6	1	A-3226-H-1230	Same as X-1142 except 2.12" overall length, includes item 77 (45220).
		B, B2, B3, B4, B6	1	A-3266-Z-1040	3266-Y-1039 casting, 8 holes 0.47" diameter on 6.00" bolt circle, 3.67" bore, without brake adapter, 1.73" overall length, includes item 77 (3720).
		B1, B5, B7	1	A-3226-H-1048	3226-G-1047 casting, 5.02" overall diameter on 6.00" bolt circle, 3.67" bore, 8 holes 0.47" diameter on 6.00" bolt circle diameter, 4 holes 0.63"-11 on 6.69" bolt circle diameter, 3.67" bore with brake adapter, includes item 77 (3720).
		B8, B10, B11	1	A-3226-E-1201	Same as H-1048 except 4.12" bore, includes item 77 (45220).
		A3, B14, B16, 101, 102	1	A-3226-F-1280	3266-U-1139 casting, 8 holes 0.47" diameter on 6.00" bolt circle, 4.12" bore 1.73" overall length, includes item 77 (45220).

## T-215 SERIES MAIN CASE

ITEM	PART NAME	MODEL	QTY	PART NUMBER	DESCRIPTION
86	Washer-input shaft bearing cage	A, A1, A2, A3, A5, A6, B, B2, B3, B4, B6, B7, B9, B10, B12, B14, B15, B16, 101, 102, 103, T101, T102	8	1229-E-1513	0.81" O.D., 0.47" I.D., 0.09" thick.
87	Capscrew-input shaft bearing cage	A, A1, A2, A3, A5, A6, B, B2, B3, B4, B6, B7, B9, B10, B12, B14, B15, B16, 101, 102, 103, T101, T102	8	S-2710-2	0.44"-14, 1.25" long, 0.62" across flats, grade 8.
88	Oil Seal-input shaft bearing cage	A, A1, A2, A5, A6, B2, B3, B6, B9, 103, T101, T102	1	A-1205-U-1529	4.00" O.D., 2.94" shaft, 0.45" wide, double lip, double case with spring, replaces A-1805-A-261 (2.75" I.D.).
		B7, B10, B12 B15	1	A-1205-S-2281	3.55" O.D., 2.75" shaft, 0.47" wide, double lip, double case with spring, replaces A-1805-D-212, (double lip, single case with spring).
89	Oil Seal-input shaft bearing cage	A1, A5, A6, B15, B16, 103, T101, T102	1	A-1205-A-2107	4.00" O.D., 3.00" I.D., 0.25" wide, single lip seal, full case.
90	Deflector-input flange/yoke	A1	1	2297-K-6303	5.09" O.D., 2.95" I.D., 0.50" wide, replaces 2297-C-627, (5.13" O.D.), included in item 91 (X-1454).
		B	1	2297-C-627	5.13" O.D., 0.69" wide, included in item 91 (U-2205).
		B2, B6, B9	1	2847-Z-312	4.81" O.D., 0.81" wide, included in item 91 (17NYS and 155TYS).
		B4	1	2847-C-367	4.75" O.D., 0.81" wide, included in item 91 (J-2454).
91	Flange/Yoke-input shaft	A, B15	1	3260-T-1294	17 NYS yoke, 2.13"-41T spline, 5.16" end hub to center cross assy.
		A1, 103	1	A-3260-X-1454	155 TYS, 2.13"-41T spline, 4 holes 0.38" diameter in ears, 4.50" end hub to center cross assy. includes item 90 (K-6303).
		B	1	3280-U-2205	148 TYS yoke, 1.75"-10T spline, 4.31" long end hub to center cross assy. has 4 holes 0.46" diameter in ears, includes item 90 (C-627).
		A2, B2	1	17NYS32-63A	17 NYS yoke, 2.00"-10T spline, 4.81" end hub to center cross assy. includes item 90 (Z-312).
		B4	1	A2-3280-J-2454	148 TYS yoke, 1.75"-10T spline, 4 holes 0.46" diameter in ears, 4.31" long end hub to center cross assy., includes item 90 (C-367).
		B6, B9	1	155TYS32-23A	155 TYS yoke, 2.00"-10T spline, 4 holes 0.38" diameter in ears, includes item 90 (Z-312).

## T-215 SERIES MAIN CASE

ITEM	PART NAME	MODEL	QTY	PART NUMBER	DESCRIPTION
92	Washer-input shaft	A, A1, B15, B16, 103	1	1229-T-1450	2.56" O.D., 1.28" I.D., 0.23" thick.
		A2, B, B2, B3, B4, B6, B7, B9, B10, B12	1	1229-K-2412	2.56" O.D., 1.28" I.D., 0.19" thick.
93	Nut-input shaft	A, A1, B15, 103	1	1227-K-1051	1.25"-12, 0.63" high, 1.63" across flats.
		A2, B, B2, B3, B4, B6, B7, B9, B10, B12	1	1227-Z-936	1.25"-18, 0.63" high, 1.63" across flats.
94	Capscrew-idler gear bearing cage	All	8	S-2710-2	0.44"-14, 1.25" long, 0.62" across flats, grade 8.
95	Washer-idler gear bearing cage	All	8	1229-E-1513	0.81" O.D., 0.47" I.D., 0.09" thick.
96	Cage Assy.-idler gear bearing	A, A1, A2, A3, A5, A6, B8, B9, B10, B11, B12, B14, B15, B16, 101, 102, 103, T102	1	A-3226-F-1280	3266-U-1139 casting, 8 holes 0.47" diameter on 6.00" bolt circle, 4.12" bore, 1.73" overall length, includes item 103 (45220).
		B, B1, B2, B3, B4, B5, B6, B7	1	A-3226-K-1051	3226-J-1050 casting, 1.73" overall length, 8 holes 0.47" diameter on 6.00" bolt circle 3.67" bore, includes item 103 (3720).
97	Shim-idler gear	All	3	2203-F-8872	0.003", use as required, 7.00" O.D., 5.06" I.D., 8 holes 0.47" diameter on 6.00" bolt circle, 2 notches 0.80" wide in I.D. equal spaced.
			3	2203-E-8871	Same as F-8872 except thickness 0.005", use as required.
			7	2203-D-8870	Same as F-8872 except thickness 0.010", use as required.
98	Plug-oil suction	-	1	P-212	Not used on T-215 models in this book.
99	Plug-transfer case	All	1	P-42	Hex socket-female, 0.13"-27 N.P.T.F. thread, 0.27" long, non-magnetic.
100	Plug-oil level	A, B16	1	1850-T-150	Female, square head, magnetic, 0.62" long, 0.75"-14 N.P.T.F.
	Plug-oil fill	All others	1	P-212	Female, square socket, non-magnetic, 0.75"-14 N.P.T.F., 0.55" long.
101	Locknut-transfer case capscrew	All	20	NL-27-1	0.44"-14, 0.38" high, 0.68" across flats, grade 8.
102	Washer-transfer case capscrew	All	20	1229-E-1513	0.81" O.D., 0.47" I.D., 0.09" thick.
103	Cup-idler gear bearing	A, A1, A2, A3, A5, A6, B8, B9, B10, B11, B12, B14, B15, B16, 101, 102, 103, T102	1	45220	4.13" O.D., included in item 96 (V-1140).
		B, B1, B2, B3, B4, B5, B6, B7	1	3720	3.67" O.D., included in item 96 (K-1051).
104	Cone-idler gear bearing	A, A1, A2, A3, A5, A6, B8, B9, B10, B11, B12, B14, B15, B16, 101, 102, 103, T102	1	45285	2.00" bore.

(Continued)

## T-215 SERIES MAIN CASE

ITEM	PART NAME	MODEL	QTY	PART NUMBER	DESCRIPTION
104	Cone-idler gear bearing	B, B1, B2, B3, B4, B5, B6, B7	1	3780	2.00" bore.
105	Gear-idler	All	1	3892-D-4840	3892-C-4839 forging, 39T, L.H. helical, 8.89" O.D.
106	Cone-idler gear bearing	A, A1, A2, A3, A5, A6, B8, B9, B10, B11, B12, B14, B15, B16, 101, 102, 103, T102	1	45285	2.00" bore.
		B, B1, B2, B3, B4, B5, B6, B7	1	3780	2.00" bore.
107	Cup-idler gear bearing	A, A1, A2, A3, A5, A6, B8, B9, B10, B11, B12, B14, B15, B16, 101, 102, 103, T102	1	45220	4.13" O.D., included in item 109 (V-1140).
		B, B1, B2, B3, B4, B5, B6, B7	1	3720	3.67" O.D., included in item 109 (K-1051).
108	Plug-oil level	A	1	1850-T-150	Female, square head, magnetic, 0.75"-14 N.P.T.F., 0.62" long.
	Plug-oil fill	All others	1	P-212	Female, square socket, non-magnetic, 0.75"-14 N.P.T.F., 0.55" long.
109	Cage Assy.-idler gear bearing	A, A1, A2, A3, A5, A6, B8, B9, B10, B11, B12, B14, B15, B16, 101, 102, 103 T102	1	A-3226-F-1280	3266-U-1139 casting, 8 holes 0.47" diameter on 6.00" bolt circle, 4.12" bore 1.73" overall length, includes item 107 (45220).
		B, B1, B2, B3, B4, B5, B6, B7	1	A-3266-K-1051	3226-J-1050 casting, 1.73" overall length, 8 holes 0.47" diameter on 6.00" bolt circle 3.67" bore, includes item 107 (3720).
110	Washer-bearing cage capscrew	All	8	1229-E-1513	0.81" O.D., 1.28" I.D., 0.23" thick.
111	Capscrew-idler gear bearing cage	All	8	S-2710-2	0.44"-14, 1.25" long, 0.62" across flats, grade 8.
112	Nut-output shaft	A2, A3, B14, 101, 102	1	1227-K-1051	1.25"-12, 0.63" high, 1.63" across flats.
		B, B1, B2, B3, B4, B5, B6, B7, B8, B9, B10, B11, B12	1	1227-Z-936	1.25"-18, 0.63" high, 1.63" across flats.
113	Washer-output shaft	A2, A3, B14, 101, 102	1	1229-T-1450	2.56" O.D., 1.28" I.D., 0.23" thick.
		B, B1, B2, B3, B4, B5, B6, B7, B8, B9, B10, B11, B12	1	1229-K-2143	2.56" O.D., 1.28" I.D., 0.19" thick.
114	Flange/Yoke-output shaft	A2, 101	1	17NYS34-20	17 NYS yoke, 2.13"- 41T spline, 5.16" end hub to center cross assembly.
		B14, 102 103	1	A-3260-T-1294	Same as 3260-T-1294 except includes item 114A (K-6303).

(Continued)

## T-215 SERIES MAIN CASE

ITEM	PART NAME	MODEL	QTY	PART NUMBER	DESCRIPTION
114	Flange/Yoke-output shaft	A3	1	3260-G-1515	148TYS yoke, 1.75"-10T spline, 4.75" end hub to center cross assy.
		B	1	A-3280-U-2205	148TYS yoke, 1.75"-10T spline, 4.31" long end hub to center cross assy., has 4 holes 0.46" diameter in ears, includes item 114A (C-627).
		B1, B2, B5, B6, B7, B8, B9, B10, B11	1	A-3260-Y-1039	17NYS yoke, 2.00"-10T spline, 4.81" end hub to center cross assy., includes item 114A (Z-312).
		B4	1	A-3280-J-2454	148TYS yoke, 1.75"-10T spline, 4 holes 0.46" diameter in ears, 4.31" long end hub to center cross assy., includes item 114A (C-367).
		A6	1	A-3260-U-1633	16TYS yoke, 2.13"-41T spline, 4 holes 0.38" diameter in ears, 2.94" end hub to center cross assy.
		T102	1	A-3260-A-79	85WBYS yoke, 2.13"-41T internal spline, 4 holes 0.50" diameter in ears, 2.94" end hub to center cross assy.
114A	Deflector-output flange/yoke	B	1	2297-C-627	5.13" O.D., 0.69" wide, included in item 114 (U-2205).
		B1, B2, B5, B6, B7, B8, B9, B10, B11	1	2847-Z-312	4.81" O.D., 0.69" wide, included in item 114 (Y-1039).
		B4	1	2847-C-367	4.75" O.D., 0.69" wide, included in item 114 (J-2454).
		B14, 102	1	2297-K-6303	5.09" O.D., 2.95" I.D., 0.50" wide, replaces 2297-C-627, (5.13" O.D.), included in item 114 (Y-1294).
115	Oil Seal-output shaft	A2, A3, B1, B2, B3, B5, B6, B7, B8, B9, B10, B11, B14, 101, 102, T102	1	A-1205-U-1529	4.00" O.D., 2.94" shaft, 0.45" wide, double lip, double case with spring, replaces A-1805-A-261, 2.75" I.D.
		B, B4	1	A-1805-A-261	4.00" O.D., 2.75" shaft, 0.45" wide, double lip, double case with spring.
115A	Oil Seal-output shaft	A3, B14, 101, 102, T102	1	A-1205-A-2107	4.00" O.D., 3.00" shaft, 0.25" side, single lip. full case.
116	Capscrew-output shaft bearing cage	A2, A3, B, B1, B2, B3, B4, B5, B6, B7, B8, B9, B10, B11, B12, B14, 101, 102, T102	8	S-2710-2	0.44"- 14, 1.25" long, 0.62" across flats, grade 8.
117	Washer-bearing cage capscrew	A2, A3, B, B1, B2, B3, B4, B5, B6, B7, B8, B9, B10, B11, B12, B14, B16, 101, 102, T102	8	1229-E-1513	0.81" O.D., 0.47" I.D., 0.09" thick.



## T-215 SERIES MAIN CASE

ITEM	PART NAME	MODEL	QTY	PART NUMBER	DESCRIPTION
118	Cage Assy.-output shaft bearing	A, A1 T101	1	3266-L-1104	3266-K-1103 casting, no fitted bearing, 1.08" high, 8 holes 0.47" diameter on 6.00" bolt circle.
		A2	1	A-3226-X-1142	3226-P-1238 casting, 8 holes 0.47" diameter on 6.00" bolt circle, 4.12" bore, 1.79" overall length, includes item 126 (45220).
		A3	1	A-3226-H-1230	Same as X-1142 except 2.12" overall length, includes item 126 (45220).
		B	1	A-3226-Z-1040	3266-Y-1039 casting, 8 holes 0.47" diameter on 6.00" bolt circle, 3.67" bore without brake adapter, 1.73" overall length, includes item 126 (3720).
		B1, B2, B3, B4, B5, B6, B7	1	A-3226-K-1051	3226-J-1050 casting, 1.73" overall length, 8 holes 0.47" diameter on 6.00" bolt circle 3.67" bore, includes item 126 (3720).
		B8, B9, B10, B11, B12, B15, 103, T101	1	A-3226-F-1280	3266-U-1139 casting, 8 holes 0.47" diameter on 6.00" bolt circle, 4.12" bore, 1.73" overall length, includes item 126 (45220).
		A5, A6, B14, B15, 101, 102, 103, T101, T102	1	A-3226-G-1255	3226-P-1238 casting, 2.12" overall length, 8 holes 0.47" diameter on 6.00" bolt circle, includes item 126 (45220).
119	Screw-name plate	All	2	9X-16	1.25" long, 0.14" diameter.
120	Name plate	All	1	2297-Y-4835	3.00" long, 1.25" high, 2 holes 0.15" diameter.
121	Capscrew-transfer case	All	20	S-2718-1	0.44"-14, 2.25" long, 0.62" across flats, grade 8.
122	Washer-transfer case capscrew	All	20	1229-E-1513	0.81" O.D., 0.47" I.D., 0.09" thick.
123	Plug-oil drain	All	1	1850-T-150	Female, square head, magnetic, 0.62" long 0.75"-14 N.P.T.F.
124	Plug-oil suction	-	1	P-212	Not used on T-215 models in this book.
125	Plug-transfer case	All	1	P-42	Hex socket-female, 0.13"-27 N.P.T.F. thread, 0.27" long, non-magnetic.
126	Cup-output shaft bearing	A, A1, T101	1	42620	5.00" O.D.
		B, B1, B2, B3, B4, B5, B6, B7	1	3720	3.67" O.D., included in item 118 (K-1051).
		A2, B8, B9, B10, B11, B12 B14, B15, B16, 101, 102, 103, T101, T102	1	45220	4.13" O.D., included in item 118 (F-1280 and X-1142).
127	Cone-output shaft bearing	A, A1, T101	1	42687	2.13" bore.
		A2, A3, B14, 101, 102, 103	1	45290	2.25" bore.
		B, B1, B2, B3, B4, B5, B6, B7	1	3780	2.00" bore.
		B8, B9, B10, B11, B12, B16	1	45285	2.00" bore.
128	Bushing-output shaft	-	1	1244-V-1790	Not used on T-215 models in this book.

## T-215 SERIES MAIN CASE

ITEM	PART NAME	MODEL	QTY	PART NUMBER	DESCRIPTION
129	Shaft-output	A	1	A-3297-A-1041	5.31" long, 1 spline 3.37"-26T with 6T dog clutch one end, 1.69" bore 2.06" deep, includes item 131 (P-1160).
		A1	1	A-3297-Z-1170	Same as A-1041 except bore 1.88", includes item 138 (A-53).
		A3	1	A-3297-B-1172	8.86" long, 1 spline 2.13"-41T, 1 spline 3.37"-26T dog clutch one end, 1.25"-12 thread one end, includes item 131 (N-1242).
130	Shaft-output	B	1	3297-P-1004	11.68" long, 1 spline 1.75"-10T 1 spline 2.50"- 10T, 1 spline 1.00"- 10T, 1.25"-18 thread both ends.
		B1, B2, B3, B5, B6, B7, B8, B9, B10, B11, B12	1	3297-Z-1144	8.5" long, 1 spline 2.00"-10T, 1 spline 2.51"-10T, 1.25"-18 thread 1 end only.
		A2, T101, T102	1	3297-B-1042	11.56" long, 2 splines 2.10"-41T, 1 spline 2.65"-52T, 1.25"-12 thread both ends.
		B14, 101, 102	1	3297-J-1206	8.15" long, 1 spline 2.10"-41T, 2.38" long, 1 spline 2.65"-52T and 1.25"-12 thread both ends.
		B4	1	3297-N-1002	7.88" long, 1 spline 1.75"-10T, 1 spline 2.50"-10T and 1.25"-18 thread 1 end only.
131	Bushing-output	A	1	1225-P-1160	1.68" O.D., 1.50" I.D., 1.25" long with split, included in item 130 (A-1041).
	Bearing-output shaft	A1	1	1228-A-53	Needle roller bearing, 1.88" O.D., 1.25" wide included in item 130 (Z-1170).
132	Gear-output shaft	A, A1, A3, A5, A6, T101	1	3892-B-4994	31T, R.H. helical, 7.18" O.D., 3.13"- 26T spline.
		A2, B14, 101 102, 103	1	3892-C-4995	3892-A-4837 forging, 31T, R.H. helical, 7.18" O.D., 3.13" major diameter- 26T spline.
		All others	1	3892-B-4838	3892-A-4837 forging, 31T, R.H. helical, 7.18" O.D., 2.50" major diameter- 10T spline.
133	Cone-output shaft bearing	A, A1, A3, A6, T101	1	42687	2.13" bore.
		A2, A6, B14, 101, 102, 103	1	45290	2.25" bore.
		B, B1, B2, B3, B4, B5, B6, B7	1	3780	2.00" bore.
		B8, B9, B10, B11, B12, B16, T101	1	45285	2.00" bore.
134	Cup-output shaft bearing	A, A1, A3, A6, T101	1	42620	5.00" O.D.
		B, B1, B2, B3, B4, B5, B6, B7	1	3720	3.67" O.D., included in item 139 (Z-1040).
		A2, B8, B9, B10, B11, B12, B14, B15, B16, 101, 102, 103	1	45220	4.13" O.D., included in item 139 (X-1142).

## T-215 SERIES MAIN CASE

ITEM	PART NAME	MODEL	QTY	PART NUMBER	DESCRIPTION
135	Collar-output shaft	A, A3	1	3107-G-1099	6 jaw teeth, 3.25" O.D., 1.56" long with shift groove, 1.91"-39T spline.
		A1	2		
		A6, T101	1	3107-B-1120	6 jaw teeth, 3.25" O.D., 1.56" long with shift groove, 1.91"-39T spline.
136	Plug-oil drain	All	1	1850-T-150	Female, square head, magnetic, 0.62" long, 0.75"-14 N.P.T.F.
137	Shim-output shaft	All	3	2203-F-8872	0.003", use as required, 7.00" O.D., 5.06" I.D., 8 holes 0.47" diameter on 6.00" bolt circle 2 notches 0.80" wide on I.D. equal spaced.
			3	2203-E-8871	Same as F-8872 except thickness 0.005", use as required.
			7	2203-D-8870	Same as F-8872 except thickness 0.010", use as required.
138	Spacer-output shaft	B, B4	1	1244-R-1760	2.31" O.D., 1.81" I.D., 0.13" thick.
139	Cage Assy.-output shaft bearing	B, B1, B2, B3, B4, B5, B6, B7	1	A-3226-Z-1040	3266-Y-1039 casting, 8 holes 0.47" diameter on 6.00" bolt circle, 3.67" bore, without brake adapter, 1.73" overall length, includes item 134 (3720).
		A2, B8, B9, B10, B11, B12	1	A-3266-X-1142	3226-P-1238 casting, 8 holes 0.47" diameter on 6.00" bolt circle, 4.12" bore, 1.79" overall length, includes item 134 (45220).
		A, A1	1	3266-L-1104	3266-K-1103 casting, no fitted bearing, 1.08" high, 8 holes 0.47" diameter on 6.00" bolt circle.
		B14, 101, 102	1	A-3226-F-1280	3266-U-1139 casting, 8 holes 0.47" diameter on 6.00" bolt circle, 4.12" bore, 1.73" overall length, includes item 134 (45220).
		A6	1	3226-F-1280	3266-U-1139 casting, 8 holes 0.47" diameter on 6.00" bolt circle, 4.12" bore, 1.73" overall length,
140	Washer-bearing cage capscrew	A, A1, A2, A5, A6, B1, B2, B3, B4, B5, B6, B7, B8, B9, B10, B11, B12, B14, B15, 101,102, 103	8	1229-E-1513	0.81" O.D., 0.47" I.D., 0.09" thick.
141	Capscrew-output shaft bearing cage	A, A1, A2, A5, A6, B1, B2, B3, B4, B5, B6, B7, B8, B9, B10, B11, B12, B14, B15, 101, 102, 103	8	S-2710-2	0.44"-14, 1.25" long, 0.62" across flats, grade 8.
142	Oil Seal-output shaft	B, B4	1	A-1805-A-261	4.00" O.D., 2.75" shaft, 0.45" wide, double lip, double case with spring.
		A2, A5, B1, B2, B3, B5, B6, B7, B8, B9, B10, B11, 103	1	A-1205-U-1529	4.00" O.D., 2.94" shaft, 0.45" wide, double lip, double case with spring, replaces A-1805-A-261, (2.75 I.D.).

## T-215 SERIES MAIN CASE

ITEM	PART NAME	MODEL	QTY	PART NUMBER	DESCRIPTION
143	Deflector-output flange/yoke	B	1	2297-C-627	5.13" O.D., 0.69" wide, included in item 144 (U-2205).
		B1, B2, B5, B6, B7, B8, B9, B10, B11	1	2847-Z-312	4.81" O.D., 0.81" wide, included in item 144 (Y-1039).
		B4	1	2847-C-367	4.75" O.D., 0.69" wide, included in item 144 (J-2454).
144	Flange/Yoke-output shaft	A2	2	17NYS34-20	17 NYS yoke, 2.13"-41T spline, 5.16" end hub to center cross assembly.
		B	1	A-3280-U-2205	148 TYS yoke, 1.75"-10T spline, 4.31" long end hub to center cross assy., has 4 holes 0.46" diameter in ears, includes item 143 (C-627).
		B1, B2, B5, B6, B7, B8, B9, B10, B11	1	17NYS32-63A	17 NYS yoke, 2.00"-10T spline, 4.81" end hub to center cross assy., includes item 143 (Z-312).
		B4	1	A-3280-J-2454	148 TYS yoke, 1.75"-10T spline, 4 holes 0.46" diameter in ears, 4.31" long end hub to center cross assy., includes item 143 (C-367).
		T102	1	A-3260-A-79	85WBYS yoke, 2.13"-41T spline, 4 holes 0.50" diameter in ears, 2.90" end hub to center cross assy.
145	Washer-output shaft	A2	1	1229-T-1450	2.56" O.D., 1.28" I.D., 0.23" thick.
		B, B1, B2, B3, B4, B5, B6, B7, B8, B9, B10, B11, B12	1	1229-K-2143	2.56" O.D., 1.28" I.D., 0.19" thick.
146	Nut-output shaft	A2	2	1227-K-1051	1.25"-12, 0.63" high, 1.63" across flats.
		B, B1, B2, B3, B4, B5, B6, B7, B8, B9, B10, B11, B12	1	1227-Z-936	1.25"-18, 0.63" high, 1.63" across flats.
-	Silicone Gasket- 3 oz. tube	All	2	2297-Z-6656	Use as required.

## T-215 SERIES 5450 LB-FT DECLUTCH / P.T.O.

ITEM	PART NAME	MODEL	QTY	PART NUMBER	DESCRIPTION
147	Nut-declutch shaft	A	1	1227-K-1051	1.25"-12, 0.63" high, 1.63" across flats.
		A1, A5	2		
148	Washer-declutch shaft	A	1	1229-T-1450	2.56" O.D., 1.28" I.D., 0.23" thick.
		A, A5	2		
149	Flange/Yoke-declutch	A	1	3260-T-1294	17 NYS yoke, 2.13"-41T spline, 5.16" end hub to center cross assembly.
		A1	2	3260-X-1454	155 TYS, 2.13"-41T spline, 4 holes 0.38" diameter in ears, 4.50" end hub to center cross assy.
		A3	1	3260-G-1515	148TYS yoke, 2.13"-41T spline, 4.75" end hub to center cross assembly.
150	Deflector-output flange/yoke	-	1	2297-K-6303	Not used on T-215 models in this book.
151	Capscrew-declutch shift cover	A, A3, A5, A6, T101	4	S-268-2	0.38"- 16, 1.00" long, 0.56" across flats, grade 8.
		A1	8		
152	Washer-declutch shift cover capscrew	A, A3, A5, A6, T101	4	1229-K-1597	0.75" O.D., 0.41" I.D., 0.09" thick.
		A1	8		
153	Cover-declutch cage	A, A3, A5, A6, T101	1	3266-N-1106	3266-M-1105 casting, 2.57" long, 2.57" wide, 0.38" thick, 4 holes 0.41" diameter and one 0.44"-20 threaded hole.
		A1	2		
154	Quad ring-declutch piston	A, A3, A5, A6, T101	1	1205-N-924	1.76" O.D., 1.49" I.D., 0.14" thick.
		A1	2		
155	Piston-declutch	A, A3, A5, A6, T101	1	2230-W-1063	3.13" long, 0.78" main body diameter.
		A1	2		
156	Spring-declutch piston return	A, A3, A5, A6, T101	1	2258-R-1136	1.01" O.D., 0.81" I.D., 2.00" free length.
		A1	2		
156A	Quad ring-declutch	A6	1	5X-1137	1.00" O.D., 0.73" I.D., 0.14" thick.
157	Fork-declutch	A, A5, A6, T101	1	3296-P-1186	3296-Y-1143 casting, 2.56" between jaws, 0.75" diameter shaft hole, 0.38"-24 UNF, harden pads 2 places, total thickness 0.53".
		A1	2		
157A	Nipple-pipe	A6	1	1199-Y-3067	2.31" long, 0.25"-18 N.P.T.F. both ends.
158	Setscrew-declutch fork	A, A3, A5, A6, T101	1	26X-1008	0.38"-24, 0.72" long with 0.14" diameter nylon pellet, female shaft hole.
		A1	2		
159	Washer-declutch plate capscrew	A, A3, A5, A6, T101	4	1229-K-1597	0.75" O.D., 0.41" I.D., 0.09" thick.
		A1	8		
160	Capscrew-declutch plate	A, A3, A5, A6, T101	4	S-266-1	0.38"-16, 0.75" long, 0.56" across flats, grade 8, replaces S-265-1, 0.62" long.
		A1	8		
161	Switch Assy.-declutch	A, A3, A5, T101	1	A-3297-A-1041	0.56"-18 thread, 13.27" overall length.
		A1, A6	2		
162	Plate-declutch	A	1	2205-T-1008	Same as Y-1039 except less 1 hole 0.56"-18.
		A1, A5, T101	2	2205-Y-1039	4.25" long, 2.63" wide, 0.19" thick, 4 holes 0.41" diameter and 1 hole 0.56"-18.
		A3	1		

## T-215 SERIES 5450 LB-FT DECLUTCH / P.T.O.

ITEM	PART NAME	MODEL	QTY	PART NUMBER	DESCRIPTION
163	Shaft-declutch	A	1	3297-U-1035	8.44" long, 1 spline 2.00"-39T, 1 spline 2.13"- 41T, 1.25"-12 thread 1 end, 1.50" diameter other end, (use with bushing).
		A1, A5, A6, T101	2	3297-A-1171	8.44" long, 1 spline 2.13"-41T, 1 spline 2.00"-39T, 1.50" long, 1.25"-12 thread 1 end, 1.50" diameter other end, (use with bearing).
		A3	1		
164	Cage-declutch bearing	A, A3	1	3226-Z-1144	3266-Y-1143 casting, 8 holes 0.47" diameter on 6.00" bolt circle, 4.58" long, 4.12" I.D., 4 holes 0.38"-16, 1 hole 1.75" diameter, 1.00" deep.
		A1, A5, T101	2	3226-V-1218	3226-U-1217 cast, 8 holes 0.47" diameter on 6.00" bolt circle, 7.40" long, one hole 0.25"-14 N.F.S.F. 0.50" deep.
		A6	1		
165	Washer-declutch cage capscrew	A, A3, A5, T101	8	1229-E-1513	0.81" O.D., 0.47" I.D., 0.09" thick.
		A1	16		
166	Capscrew-declutch brg. cage	A, A3, A5, T101	8	S-2710-2	0.44"-14, 1.25" long, 0.62" across flats, grade 8.
		A1	16		
167	Bearing-declutch shaft ball	A, A3, A5, A6, T101	1	1228-V-204	Ball bearing, 3.94" O.D., 2.17" bore, 0.82" wide.
		A1	2		
168	Snap Ring-retaining	A, A3, A5, A6, T101	1	1854-C-315	Fits 4.06" diameter groove, 0.22" wide, 0.09" thick.
		A1	2		
169	Oil Seal Assy.-declutch cage	A, A3, A5, A6, T101	1	A-1205-U-1529	4.00" O.D., 2.94" shaft, 0.45" wide, double lip, double case with spring, replaces A-1805-A-261, (2.75" I.D.).
		A1	2		
170	Oil Seal Assy.-declutch cage	A3	1	A-1205-A-2107	4.00" O.D., 3.00" I.D., 0.25" wide, single lip, full case.
		A1, A5, A6, T101			
-	Silastic- 3 oz. tube	All	1	2297-Z-6656	Use as required.

## T-2111 SERIES DCM BRAKES

ITEM	PART NAME	MODEL	QTY	PART NUMBER	DESCRIPTION
1	Locknut-brake	PD100, PD101, PD102, PD103, PD104, PD106	1	1227-K-1051	1.25"- 12, 0.63" high, 1.63" across flats.
2	Washer-brake	PD100, PD101, PD102, PD103, PD104, PD106	1	1229-T-1450	2.58" O.D., 1.28" I.D., 0.23" thick.
3	Nut-brake drum to flange	PD100	8	N-16-1	0.38"-24, 0.56" across flats, grade 8.
4	Spacer-brake drum to flange	PD100	8	1844-U-411	Split spacer, 0.39" I.D., 0.50" long.
5	Flange/Yoke-brake drum	PD100, PD101, PD104	1	3280-U-7535	5 WCS flange, 2.13"- 41T spline, 8 holes 0.44" diameter on 7.25" bolt circle, 3.00" end hub to end flange mounting face.
		PD102	1	17NYS34-20	17 NYS yoke, 2.13"- 41T spline, 5.16" end hub to center cross assy.
		PD103	1	3260-D-1460	17 NYS yoke, 2.13"-41T spline, 2.50" spline length.
6	Drum-brake	PD100	1	3219-H-4064	3219-G-4063 rough stamping, 8 holes 0.38" diameter on 7.25" bolt circle, 5.88" I.D., 12.75" O.D., 0.31" thick.
7	Lockwire-brake drum to hub capscrew	-	2	LW-168	Not used on T-2111 models in this book.
8	Bolt-brake drum to hub	PD100	8	10X-507	0.38"-24, 1.75" long, 27 serrations on bolt body.
9	Spacer-brake to hub	-	1	1244-S-1761	Not used on T-2111 models in this book.
10	Spring-brake shoe return	PD100	4	2758-A-53	11 coils, 0.75" O.D., 2.75" long.
11	Brake Shoe and Lining Assy.	PD100	2	A3-3722-D-420	12" x 3", non-asbestos, includes items 12 and 13, (replaces asbsetos A1-3722-D-420).
12	Lining-brake	PD100	2	2240-Y-5381	Included in item 11, lining and rivets sold separately or in Kit 2000-P-1446.
13	Rivet-Lining to shoe	PD100	28	RV-876	
14	Strut Assy.	PD100	1	A-3787-N-14	10.75" long, 5.40" diameter bore.
15	Camshaft	PD100	1	2710-U-151	2710-X-154 forging, 3.17" long, 32 serrations 1 end, 0.56"-12 thread 1 end.
16	Backing Plate Assy.	PD100	1	A-3736-K-375	5.50" I.D. pilot, 4 holes 0.67" diameter, includes anchor pin 1759-Y-51 (2 pieces).
17	Capscrew-cover adapter cage	PD100	4	10X-1438	0.63"-11, 1.88" long, grade 8, 0.94" across flats with locitite patch.
18	Washer-cover adapter to cage	-	4	1229-U-1503	Not used on T-2111 models in this book.
19	Lever-brake	PD100	1	302-Z-676	302-Y-675 casting, 4.12" from 1.00" diameter hole to 0.56" diameter hole, 32 serrations on bore I.D.
20	Washer-brake	PD100	1	WA-39	1.19" O.D., 0.59" I.D., 0.09" thick.
21	Nut-lock	PD100	1	1779-Z-260	0.56"-12, 1.00" across flats.
22	Deflector-brake adapter	PD100	1	3264-W-101	5.00" O.D., 3.38" I.D., 2 step profile.
		PD101	1	2297-C-627	5.13" O.D., 0.68" wide.
23	Dust shield	PD100	1	3264-V-100	13.24" O.D., 5.51" I.D., 0.06" thick, 4 holes 0.66" diameter on 6.69" bolt circle.
24	Oil Seal-brake bearing cage	PD101	1	A-1205-T-2152	Triple lip seal, 3.89" O.D., 2.88" I.D., 0.59" wide, included in item 29 (V-1426).
		PD102, PD103, PD104	1	A-1205-U-1529	4.00" O.D., 2.94" shaft, 0.45" wide, double lip, double case with spring, included in item 29 (Y-1481), replaces A-1805-A-261, (2.75" I.D.).

## T-2111 SERIES DCM BRAKES

ITEM	PART NAME	MODEL	QTY	PART NUMBER	DESCRIPTION
25	Oil Seal-brake bearing cage	PD103, PD104	1	A-1205-A-2107	4.00" O.D., 3.00" I.D., 0.25" wide, single lip seal full case, included in item 29, (Y-1481).
26	Cage Assy.-brake bearing	-	1	A-3226-F-1046	Not used on T-2111 models in this book.
27	Capscrew-brake bearing cage	PD101, PD102, PD103, PD104	4	S-21014-1	0.63"-11, 1.75" long, 0.93" across flats, grade 8.
28	Washer-brake bearing cage capscrew	PD101, PD102, PD103, PD104	4	1229-U-1503	1.06" O.D., 0.66" I.D., 0.09" thick.



## T-2111 SERIES PROPORTIONAL DIFFERENTIAL

ITEM	PART NAME	MODEL	QTY	PART NUMBER	DESCRIPTION
29	Adapter-brake assy.	PD100	1	3268-P-1394	Same as V-1426 except add one 0.19" diameter oil lube hole.
		PD101	1	A-3268-V-1426	3268-N-1392 casting, 3.88" main bore, 1.31" overall height, includes item 24 (T-2152).
		PD102, PD103, PD104, PD106	1	A-3268-Y-1481	3268-N-1392 casting, 4.00" main bore, includes item 24 (U-1529) and 25.
30	Cone-proportional diff. cage shaft	PD100, PD101, PD102, PD103, PD104, PD106	1	390	2.25" bore.
31	Cup-proportional diff. cage shaft	PD100, PD101, PD102, PD103, PD104, PD106	1	394A	4.33" O.D.
32	Capscrew-diff. cage to gear case cover	PD100, PD101, PD102, PD103, PD104, PD106	12	S-2710-2	0.44"-14, 1.25" long, 0.62" across flats, grade 8.
33	Washer-diff. cage to gear case cover	PD100, PD101, PD102, PD103, PD104, PD106	12	1229-E-1513	0.81" O.D., 0.47" I.D., 0.09" thick.
34	Cage-proportional diff.	PD100, PD101, PD102, PD103, PD104, PD106	1	A-3238-T-1008	3238-S-1007 casting, 5.86" overall length, 14.00" O.D., 12 holes 0.47" diameter on 13.00" bolt circle, 4 holes 0.63"-11 on small flange.
35	Plug-oil drain	PD100, PD101, PD102, PD103, PD104, PD106	1	1850-T-150	Female, square head, magnetic, 0.62" long, 0.75"- 14 N.P.T.F.
36	Shim-proportional diff. cage bearing spacer	PD100, PD101, PD102, PD103, PD104, PD106	2	2203-W-9851	0.48" use as required, 2.88" O.D., 2.31" I.D.
			2	2203-X-9852	Same as W-9851 except thickness 0.482", use as required.
			2	2203-Y-9853	Same as W-9851 except thickness 0.490", use as required.
			2	2203-Z-9854	Same as W-9851 except thickness 0.498", use as required.
			2	2203-A-9855	Same as W-9851 except thickness 0.506", use as required.
			2	2203-B-9856	Same as W-9851 except thickness 0.510", use as required.
37	Cup-proportional diff. cage shaft	PD100, PD101, PD102, PD103, PD104, PD106	1	394A	4.33" O.D.
38	Cone-proportional diff. cage shaft	PD100, PD101, PD102, PD103, PD104, PD106	1	390	2.25" bore.
39	Shaft-output outer	PD100, PD101, PD102, PD103, PD104, PD106	1	3297-K-1051	7.75" long, 1 spline 2.13"- 41T, 1 spline 3.10"-30T, 1.46" long, 1.25"-12 thread 1 end.
40	Gear-proportional diff. ring	PD100, PD101, PD102, PD103, PD104 PD106	1	3297-Q-4827	3892-E-3515 forging, 46T internal spur with 8.94" gear I.D., 10.47" hub O.D., 2.90" overall width, 2.88" major diameter 30T spline.
41	Snap Ring-planet. pinion shaft	PD100, PD101, PD102, PD103, PD104, PD106	3	1854-Z-182	0.16" wide, 0.09" thick, fits into 1.41" groove.

# T-2111 SERIES PROPORTIONAL DIFFERENTIAL

ITEM	PART NAME	MODEL	QTY	PART NUMBER	DESCRIPTION
42	Washer-planet. pinion thrust	PD100, PD101, PD102, PD103, PD104, PD106	3	1229-F-2814	2.12" O.D., 1.51" I.D., 0.12" thick.
43	Pinion-Planet. Spider	PD100, PD101, PD102, PD103, PD104, PD106	3	3891-Q-1629	13T spur, 2.90" O.D., 1.50" I.D.
44	Shaft-planet. pinion	PD100, PD101, PD102, PD103, PD104, PD106	3	3198-D-30	3.22" long, 1.50" diameter has 0.13" wide snap ring groove 1 end nylon applied to one end.
45	Spider Assy.-planet. gear	PD100, PD101, PD102, PD103, PD104, PD106	1	A1-3298-H-1048	Base planetary spider less planetary pinion shafts and setscrews, 2.86"-58T spline, includes items 41, 42 43, 44, and 46.
46	Setscrew-planet. pinion shaft	PD100, PD101, PD102, PD103, PD104, PD106	3	26X-237	0.38"-16, 0.50" long, male hex head, 0.19" across flats.
47	Snap Ring-outer output shaft	PD100, PD101, PD102, PD103, PD10, PD106	1	1854-S-149	0.19" wide, 0.09" thick, fits into 2.84" diameter groove.
48	Gear-planet. sun	PD100, PD101, PD102, PD103, PD104, PD106	1	3892-Z-3588	20T spur, 4.28" O.D., 1.68" major diameter, 19T spline.
49	Snap Ring-inner output shaft	PD100, PD101, PD102, PD103, PD104, PD106	1	1854-S-149	0.19" wide, 0.09" thick, fits into 2.84" diameter groove.
50	Capscrew-output shaft cage	PD100, PD101, PD102, PD103, PD104,	8	S-2710-2	0.44"-14, 1.25" long, 0.62" across flats, grade 8.
51	Washer-output shaft cage capscrew	PD100, PD101, PD102, PD103, PD104, PD106	8	1229-E-1513	0.81" O.D., 0.47" I.D., 0.09" thick.
52	Spacer-output shaft planet. spider	PD100, PD101, PD102	1	1244-S-1813	3.50" O.D., 3.00" I.D., 0.71" thick.
53	Cover-proportional diff. gear case	PD100, PD101, PD102, PD103, PD104, PD106	1	3266-A-1119	3266-Z-1118 casting, 3.08" overall length, 14.00" O.D., 12 holes 0.44"-14, 13.00" bolt circle, 8 holes 0.47" diameter on 6.00" bolt circle.
54	Plug-oil fill hole	PD100, PD101, PD102, PD103, PD104, PD106	1	P-212	Female, square socket, non-magnetic 0.75" 14 N.P.T.F., (0.55" long).

## T-2111 SERIES MAIN CASE

ITEM	PART NAME	MODEL	QTY	PART NUMBER	DESCRIPTION
55	Nut-input shaft lock	D101, D102, D103, D105, D106, D107, D108, D109, D111, D112, D113, D116, HP100, PD102, PD103, PD106, T105, T106	1	1227-K-1051	1.25"-12, 0.63" high, 1.63" across flats.
		T100, T101, T102, T103, T104, T105, T106, T107	1	1227-J-946	1.50"-12, 0.73" high, 1.84" across flats.
		T108	2		
56	Washer-input shaft	D101, D102, D103, D105, D106, D107, D108, D109, D111, D112, D113, D116, HP100, PD102, PD103, PD106 T106	1	1229-T-1450	2.56" O.D., 1.28" I.D., 0.23" thick.
		T100, T101 T102, T103, T104, T105, T106, T107	1	1229-R-1734	2.88" O.D., 1.53" I.D., 0.22" thick.
		T108	2		
57	Flange/Yoke-input shaft	D101, D106	1	17NYS34-20	17NYS yoke, 2.13"-41T spline, 5.16" end hub to center cross assy.
		D103, D108 D111, D112 D117, PD103, T105, T106	1	A-3260-D-1460	17NYS yoke, 2.13"-44T spline, 2.50" spline length, includes item 58.
		D102	1	A-3260-S-1449	18NYS yoke, 2.13"-41T spline, 5.75" end hub to center cross assy., includes item 58 (K-6303).
		D105, D109	1	3260-D-1512	18NYS yoke, 2.13"-41T spline, 5.94" long end hub to center cross assy.
		D107, D111, D112	1	A-3260-D-1512	Same as 3260-D-1512 except includes item 58.
		PD102	1	A-3260-T-1294	Same as 17NYS34-20 except includes item 58 (K-6303).
		T100	1	A-3260-Q-1421	18TYS yoke, 2.29"-44T spline, 5.75" end hub to center cross assy., 4 holes 0.50"-20 in ears, includes item 58.
		T101	1	A-3260-P-1420	17TYS yoke, 2.29"-44T spline, 5.66" end hub to center cross assy., 4 holes 0.50"-20 in ears, includes item 58.
		T102, T107	1	3260-P-1420	Same as A-3260-P-1420 less item 58.

(Continued)

## T-2111 SERIES MAIN CASE

ITEM	PART NAME	MODEL	QTY	PART NUMBER	DESCRIPTION
57	Flange/Yoke-input shaft	PD106	1	A-3260-C-1407	17TYS yoke, 2.13"-41T spline, 3.50" end hub to center cross assy., 4 holes 0.50"-20 in ears, available as assy. only.
		T103, T104	1	3260-Q-1421	Same as A-3260-Q-1421 less item 58.
		D116	1	3260-C-1511	5WCS flange, 2.13"-41T spline, 12 holes 0.48" in diameter on 7.25" bolt circle, 3.19" long end hub to flange mounting face.
58	Deflector-input shaft	D102, D103, D107, D108, D111, D112, D117, PD102, T100, T101, T106, T107	1	2297-K-6303	5.09" O.D., 2.95" I.D., 0.50" wide, replaces 2297-C-627, (5.13" O.D.) included in item 57.
59	Oil Seal-input shaft bearing cage	D100, D101, D102, D103, D105, D106, D107, D108, D109, D111, D112, D113, D117, HP100, PD102, PD103, PD106, T100, T101, T102, T103, T104, T105, T106, T108	1	A-1205-U-1529	4.00" O.D., 2.94" shaft, 0.45" wide, double lip, double case with spring, replaces A-1805-A-261, (2.75" I.D.).
60	Oil Seal-input shaft bearing cage	D100, D101, D102, D103, D105, D106, D107, D108, D109, D111, D112, D113, D117, HP100, PD102, PD103, PD106, T100, T101, T102, T103, T104, T105, T106, T108	1	A-1205-A-2107	4.00" O.D., 3.00" shaft. 0.25" wide, single lip, full case.
61	Capscrew-input shaft bearing cage	All	8	S-2710-2	0.44"-14, 1.25" long, 0.62" across flats, grade 8.
62	Washer-bearing cage capscrew	All	8	1229-E-1513	0.81" O.D., 0.47" I.D., 0.09" thick.
63	Cage Assy.-input shaft bearing	D101	1	A-3268-J-1492	3268-C-1381 casting, 5.00" long, 1 end has 8 holes 0.47" diameter on 6.00" bolt circle 1 end has 4 holes 0.63"-11, 4.00" bore 1 end for seal installation, with item 69 (42620), item 59 (U-1529) and item 60 (A-2107) installed.
	(Continued)				

## T-2111 SERIES MAIN CASE

ITEM	PART NAME	MODEL	QTY	PART NUMBER	DESCRIPTION
63	Cage Assy.-input shaft bearing	D102, D110, D111, D112, D113, D116, HP100, PD100, PD101, PD102, PD104, PD106, T106, T107	1	A-3226-F-1280	3266-U-1139 casting, 8 holes 0.47" diameter on 6.00" bolt circle, 4.12" bore 1.73" overall length, includes item 69 (45220).
		D100, T100, T101	1	A-3226-X-1142	3226-P-1238 casting, 8 holes 0.47" diameter on 6.00" bolt circle, 4.12" bore, 1.79" overall length, includes item 69 (45220).
		D103, D105, D106, D107, D108, D109, D113, D117, PD103, T102, T103, T104, T105, T106, T108	1	A-3226-G-1255	3226-P-1238 casting, 2.12" overall length, 8 holes 0.47" diameter on 6.00" bolt circle includes item 69 (45220).
64	Plug-transfer case	All	1	P-42	Hex socket-female, 0.13"-27 N.P.T.F. thread, 0.27" long, non-magnetic.
65	Plug-transfer case	D103, D105, D106, D107, D108, D109, D110, D111, D112, D113, D117, HP100, PD106, T102, T103, T104, T105, T106, T107, T108	1	P-26	Square socket, 0.38"-16 N.P.T.F. thread, 0.41" long, non-magnetic.
66	Case-transfer	D100, D101, PD100, PD101, PD102, PD103, PD104, T100, T101	1	3290-F-1020	3290-E-1019 casting, 28.88" high x 13.00" wide.
		D102, D103 D105, D106, D107, D108, D109, D110, T102, T103, T104	1	3290-N-1054	Same as F-1020 except 1 drilled hole 0.75"-14 on bottom right face of case body and 1 drilled hole 0.38"-18 in top case mounting flange.
67	Plug-transfer case	All	1	P-42	Hex socket-female, 0.13"-27 N.P.T.F. thread, 0.27" long, non-magnetic.
68	Dowel-transfer case	All	2	1846-Z-312	0.28" diameter, 1.00" long.

## T-2111 SERIES MAIN CASE

ITEM	PART NAME	MODEL	QTY	PART NUMBER	DESCRIPTION
69	Cup-input shaft bearing	D100, D102, D103, D105, D106, D107, D108, D109, D110, D111, D112, D113, D117, PD100, PD101, PD102, PD103, PD104, PD106, T100, T101, T102, T103, T104, T105, T106, T107, T108	1	45220	4.13" O.D., included in item 63 (J-1492). (X-1142, F-1280, and G-1255).
		D101	1	42620	5.00" O.D., included in item 63 (J-1492).
70	Cone-input shaft bearing	D100, D102, D103, D105, D106, D107, D108, D109, D110, D111, D112, D113, PD100, PD101, PD102, PD103, PD104, PD106, T100, T101, T102, T103, T104, T105, T106, T107, T108	1	45290	2.25" bore.
		D101	1	42687	3.00" bore.
71	Shaft-input	D100, D102, PD100, PD101, PD102	1	3297-F-1046	8.65" long, 1 spline 2.65"-52T, 1 spline 2.13"-41T, 1.25"-12 thread 1 end.
		D105, D106, D109, D111, D112, D116, PD103, PD106, T108	1	3297-F-1202	8.84" long, 1 spline 2.13"-52T, 1 spline 2.13"- 41T, 1 end has 1.25"- 12 thread.
72	Shaft-input	D101	1	A-3297-W-1037	12.69" long, 1 spline 2.13"-41T, 1 spline 3.38"-26T, 6 dog clutch teeth 1 end, 1.69" bore same end 1.50" deep, 1.25"-12 thread 1 end, includes item 73.
		D103, D107, D108, D110, D111, D112, D116, D117, HP100	1	3297-W-1167	14.15" long, 1 spline 2.13"-41T, 1 spline 2.65"- 52T, 1 spline 2.20"- 43T, 1.25"-12 thread 1 end.
		T100, T101, T102, T103, T104, T105, T106, T107, T108	1	3297-K-1155	13.07" long, 2 splines 2.25"-44T, 1 spline 2.65"-52T, 1.50"-12 thread both ends.

## T-2111 SERIES MAIN CASE

ITEM	PART NAME	MODEL	QTY	PART NUMBER	DESCRIPTION
73	Bushing-input	D101	1	1225-P-1160	1.68" O.D., 1.50" I.D., 1.25" long with split included in item 72 (W-1037).
74	Gear-input shaft	D100, D102, D103, D105, D106, D107, D108, D109, D110, D111, D112, D113, D116, D117, HP100, PD100, PD101, PD103, PD104, PD106, T100, T101, T102, T103, T104, T105, T106, T107, T108	1	3892-T-5220	3892-S-5219 forging, 22T helical, R.H., 2.08" major diameter- 52T spline, face with 2.55" replaces 3892-L-5004, (gear face 2.38" wide).
		D101, PD102	1	3892-R-5218	22T, helical, R.H., 3.40" major diameter- 26T spline, gear face width 2.55", replaces 3892-G-4999, (gear face width 2.13").
75	Spacer-input shaft	D100, D101, D102	1	1244-U-1789	2.75" O.D., 2.25" I.D., 3.00" long.
76	Cone-input shaft bearing	D100, D102, D105, D106, D109, D111, D112, D113, D116, D117, HP100, PD100, PD101, PD102, PD103, PD104, T100, T101, T102, T103, T104, T105, T106, T108	1	45290	2.25" bore.
		D101	1	45291	2.25" bore.
		D103, D107, D108, D110, D111, D112, D113, D116, D117, HP100, T107	1	39580	2.25" bore.
77	Cup-input shaft bearing	D107, D108, D110, D117	1	39520	4.44" O.D.
		All others	1	45220	4.13" O.D., included in item 85.
78	Plug-transfer case	All	1	P-42	Hex socket-female, 0.13"-27 N.P.T.F. thread 0.27" long, non-magnetic.
79	Case-transfer	PD103, PD104	1	3290-F-1020	3290-E-1019 cast, 28.88" high x 13.00" wide.
		D113, D117, HP100	1	A-3290-J-1076	3290-H-1074 cast, 14.31" x 2.88", 6.00" bolt circle 3 places, tap drill 1.00" deep, 0.44"-14 UNC 0.81" deep 8 holes 3 places, available as assembly only.
(Continued)					

## T-2111 SERIES MAIN CASE

ITEM	PART NAME	MODEL	QTY	PART NUMBER	DESCRIPTION
79	Case-transfer	D111, D112, D113, D116, D117, HP100, PD106, T105, T106, T107, T108	1	3290-J-1076	Same as A-3290-J-1076 except not assembled.
		All others	1	3290-N-1054	Same as F-1020 except 1 drilled hole 0.75"-14 on bottom right face of case body and 1 drilled hole 0.38"-18 in top case mounting flange.
80	Plug-transfer case	D103, D105, D106, D107, D108, D109, D110, D111, D112, D113, HP100, PD106, T102, T103, T104, T105, T107	1	P-26	Square socket, 0.38"-16 N.P.T.F. thread, 0.41" long, non-magnetic.
81	Elbow-oil breather	-	1	1898-H-216	Not used on T-2111 models in this book.
82	Breather-transfer case	All	1	A-1199-C-1043	1.06" long with 0.13"-27 N.P.S.F., replaces A-1199-J-166 ( 1.00" long).
83	Shim-input shaft	All	3	2203-F-8872	0.003", use as required, 7.00" O.D., 5.06" I.D., 8 holes 0.47" diameter on 6.00" bolt circle 2 notches 0.80" wide on I.D. equal spaced.
			3	2203-E-8871	Same as F-8872 except thickness, 0.005", use as required.
			7	2203-D-8870	Same as F-8872 except thickness, 0.010", use as required.
84	Spacer-input shaft	D100, D101, D102	1	1244-V-1790	4.00" O.D., 2.31" I.D., 0.50" thick.
85	Cage Assy.-input shaft bearing	D102, PD100, PD101, PD102, T100, T101	1	A-3226-X-1142	3226-P-1238 casting, 8 holes 0.47" diameter on 6.00" bolt circle, 4.12" bore, 1.79" overall length, includes item 77.
		D100, D109, D111, D112, D113, D116, PD103, PD106, T105, T106, T107, T108	1	A-3226-F-1280	3266-Y-1039 casting, 8 holes 0.47" diameter on 6.00" bolt circle, 3.67" bore, without brake adapter, 1.73" overall length, includes item 77.
		D111, D112, D113, D116, HP100, PD104, PD106, T102, T103, T104, T105, T106, T107, T108	1	A-3226-G-1255	3226-P-1238 casting, 2.12" overall length, 8 holes 0.47" diameter on 6.00" bolt circle, includes item 77.
		D105, D106	1	A-3226-H-1230	Same as X-1142 except 2.12" overall length, includes item 77 (45220).



## T-2111 SERIES MAIN CASE

ITEM	PART NAME	MODEL	QTY	PART NUMBER	DESCRIPTION
86	Washer-bearing cage capscrew	D100, D102, D105, D106, D109, D111, D112, D113, D116, D117, HP100, PD101, PD103, PD104, PD106, T100, T101, T102, T103, T104, T105, T106, T107, T108	8	1229-E-1513	0.81" O.D., 0.47" I.D., 0.09" thick.
87	Capscrew-input shaft bearing cage	D100, D102, D105, D106, D109, D117, PD100, PD101, PD102, PD103, PD104, T100, T101, T102, T103, T104, T106	8	S-2710-2	0.44"-14, 1.25" long, 0.62" across flats, grade 8.
88	Oil Seal-input shaft bearing cage	D100, PD100, PD101	1	A-1205-S-2151	4.00" O.D., 2.94" shaft, 0.59" wide, triple lip seal 2.88" I.D.
		D105, D106, D111, D112, D113, D116, D117, HP100, PD104, PD106, T100, T101, T102, T103, T104, T105, T106, T107, T108	1	A-1205-U-1529	4.00" O.D., 2.94" shaft, 0.59" wide, double lip, double case with spring, replaces A-1805-A-261, (2.75" I.D.).
89	Oil Seal-input shaft bearing cage	D105, D106, D111, D112, D113, D116, D117, HP100, PD104, PD106, T100, T101, T102, T103, T104, T105, T106, T107, T108	1	A-1205-A-2107	4.00" O.D., 3.00" shaft, 0.25" wide, single lip, full case.
90	Deflector-input flange/yoke	D102, D111, D112, PD102, T100, T101, T107	1	2297-K-6303	5.09" O.D., 2.95" I.D., 0.50" high, replaces 2297-C-627, (5.13" O.D.).
		PD100, PD101	1	2297-C-627	5.13" O.D., 0.69" long, included in item 91 (U-7535).
91	Flange/Yoke-input shaft	D100	1	3260-R-1344	5 WCS flange, 2.13"-41T spline, 12 holes 0.44" diameter on 7.25" bolt circle, 3.00" end hub to center cross assembly.
	(Continued)				

## T-2111 SERIES MAIN CASE

ITEM	PART NAME	MODEL	QTY	PART NUMBER	DESCRIPTION
91	Flange/Yoke-input shaft	D102	1	A-3260-S-1449	18 NYS yoke, 2.13"-41T spline, 5.75" end hub to center cross assy., includes item 90 (K-6303).
		PD100, PD101	1	A-3280-U-7535	5 WCS flange, 2.13"-41T spline, 8 holes 0.44" diameter on 7.25" bolt circle, 3.00" end hub to end flange mounting face, includes item 90 (C-627).
		PD102	1	A-3260-T-1294	17 NYS yoke, 2.13"-41T spline, 5.16" end hub to center cross assy., includes item 90 (K-6303).
		T100	1	A-3260-Q-1421	18 TYS yoke, 2.29"-44T spline, 5.75" end hub to center cross assy., 4 holes 0.50"-20 in ears, includes item 90 (K-6303).
		T101	1	A-3260-P-1420	17 TYS yoke, 2.29"-44T spline, 5.66" end hub to center cross assy., 4 holes 0.50"-20 in ears, includes item 90 (K-6303).
		D116, PD104	1	3260-C-1511	5WCS flange, 2.13"-41T spline, 12 holes 0.48" in diameter on 7.25" bolt circle, 3.19" long end hub to flange mounting face, includes item 90 (C-627).
		T102, T107	1	3260-P-1420	Same as A-3260-P-1420 less item 90.
		PD106	1	A-3260-C-1407	17TYS yoke, 2.13"-41T spline, 3.50" end hub to center cross assy., 4 holes 0.50"- 20 in ears,available as assembly only.
		HP100	1	3260-V-1686	5WCS flange, 2.13"-41T spline, 8 holes 0.38" diameter on 7.25" bolt circle, 3.47" end hub to flange mounting face.
		T103, T104	1	3260-Q-1421	Same as A-3260-Q-1421 less item 90.
92	Washer-input shaft	D100, D111, D112, D113, D116, HP100, PD101, PD104, PD106, T100, T101, T106	1	1229-T-1450	2.56" O.D., 1.28" I.D., 0.23" thick.
		T102, T103, T105, T106, T107	1	1229-R-1734	2.88" O.D., 1.53" I.D., 0.22" thick.
		T108	2		
93	Nut-input shaft	D100, D102, D111, D112, D113, D116, HP100, PD100, PD101, PD104, PD106, T100, T101, T106	1	1227-K-1051	1.25"-12, 0.63" high, 1.63" across flats.
		T102, T103, T104, T106	1	1227-J-946	1.50"-12, 0.73" high, 1.84" across flats.
94	Capscrew-idler gear bearing cage	All	8	S-2710-2	0.44"-14, 1.25" long, 0.62" across flats, grade 8.
95	Washer-bearing cage capscrew	All	8	1229-E-1513	0.81" O.D., 0.47" I.D., 0.09" thick.

## T-2111 SERIES MAIN CASE

ITEM	PART NAME	MODEL	QTY	PART NUMBER	DESCRIPTION
96	Cage Assy.-idler gear bearing	D103, D107, D108, D110, D117, HP100, T103, T106, T108	1	A-3226-J-1206	3226-H-1024 casting, 1.73" overall length, 8 holes 0.47" diameter on 6.00" bolt circle 4 holes 0.31"-18, includes item 103.
		All others	1	A-3266-F-1280	3266-U-1139 casting, 8 holes 0.47" diameter on 6.00" bolt circle, 4.12" bore, 1.73" overall length, includes item 103.
97	Shim-idler gear	All	3	2203-F-8872	0.003", use as required, 7.00" O.D., 5.06" I.D., 8 holes 0.47" diameter on 6.00 bolt circle 2 notches 0.80" wide on I.D.equal spaced.
			3	2203-E-8871	Same as F-8872 except thickness, 0.005", use as required.
			7	2203-D-8870	Same as F-8872 except thickness, 0.010", use as required.
98	Plug-oil suction	D102, D105, D106, D111, D112, D113, D116, HP100, PD106, T102, T105, T106, T107, T108	1	P-212	Female, square socket, non-magnetic, 0.75"-14 N.P.T.F., 0.55" long.
99	Plug-transfer case	All	1	P-42	Hex socket-female, 0.13"-27 N.P.T.F. thread, 0.27" long, non-magnetic.
100	Plug-oil fill	All	1	P-212	Female, square socket, non-magnetic, 0.75"-14 N.P.T.F., 0.55" long.
101	Locknut-transfer case capscrew	All	20	NL-27-1	0.44"-14, 0.38" high, 0.68" across flats, grade 8.
102	Washer-transfer case capscrew	All	20	1229-E-1513	0.81" O.D., 0.47" I.D., 0.09" thick.
103	Cup-idler gear bearing	All	1	45220	4.13" O.D., included in item 96.
104	Cone-idler gear bearing	All	1	45290	2.25" bore.
105	Gear-idler	D102, D105, D112, D113, D116, HP100, PD106, T105, T106, T107	1	3892-Z-5226	Same as Q-5217 except with 0.55" diameter hole on idler shaft end, 1 side only.
		D103, D106, D107, D108, D109, D110, D111, D113, D116, HP100, T103, T104, T106	1	A-3892-Z-5226	Same as 3892-Z-5226 except includes item 203.
		D117	1	A-3892-V-5352	Same as Q-5217 except assembled with 2297-A-6423 drive button.
		D117	1	3892-V-5352	Same as A-3892-V-5352 except no drive button assembled.
		All others	1	3892-Q-5217	3892-P-5216 forging, 25T, helical, L.H., 9.25" O.D., 2.75" face width, replaces 3892-J-5002, (2.50" face width).
106	Cone-idler gear bearing	All	1	45290	2.25" bore.
107	Cup-idler gear bearing	All	1	45220	4.13" O.D., included in item 109 (V-1140).

## T-2111 SERIES MAIN CASE

ITEM	PART NAME	MODEL	QTY	PART NUMBER	DESCRIPTION
108	Plug-oil drain	D111, D112, D113, D116, HP100, T105, T106, T107	1	1850-T-150	0.75"-14 P.T.F. external taper pipe thread, free fit on 0.50" square 0.31" deep.
		D117, T108	2		
		All others	1	P-212	Female, square socket, non-magnetic, 0.75"-14 N.P.T.F., 0.55" long.
108A	Cap-filler plug	D116, D117, T106	1	1199-J-894	0.75" Std. pipe thd.
108B	Pipe-nipple oil level	D113, PD106 T106	1	2296-W-1063	2.50" overall length, 0.75"-14 N.P.T.F. 1.05" diameter, 5 pint capacity.
		D117	1	1898-A-261	3.75" long, 0.75"-14 N.P.T.F., 6 pint capacity.
108C	Elbow	D113, D117, PD106, T106	1	1898-C-835	0.75"-14 N.P.T.F. thread, 90 degree.
		-	1	1898-S-201	Used on 3 and 4 pint capacity, 0.75"-14 N.P.T.F.
108D	Nipple	D111, D112, D113, D116, D117, PD106, T105, T106, T107, T108	1	1898-D-836	0.75" Std. pipe thread, 0.50" long, 0.82" I.D., 1.05" O.D.
109	Cage Assy.-idler gear bearing	All	1	A-3226-F-1280	3266-U-1139 casting, 8 holes 0.47" diameter on 6.00" bolt circle, 4.12" bore 1.73" overall length, includes item 107 (45220).
110	Washer-bearing cage capscrew	All	8	1229-E-1513	0.81" O.D., 0.47" I.D., 0.09" thick.
111	Capscrew-idler gear bearing cage	All	8	S-2710-1	0.44"- 14, 1.25" long, 0.62" across flats, grade 8.
112	Nut-output shaft	D110, D111, D112, D113, D116, HP100, PD102, PD103, PD104, PD106	1	1227-K-1051	1.25"- 12, 0.63" high, 1.63" across flats.
113	Washer-output shaft	D110, D111, D112, D113, D116, HP100, PD102, PD103, PD104, PD106	1	1229-T-1450	2.56" O.D., 1.28" I.D., 0.23" thick.
114	Flange/Yoke-output shaft	PD103	1	17NYS34-20	17 NYS yoke, 2.13"- 41T spline, 5.16" end hub to center cross assy.
		D110	1	3260-C-1511	5WCS flange, 2.13"-41T spline, 12 holes 0.48" diameter on 7.25" bolt circle, 3.19" long end hub to flange mounting face.
		PD102	1	A-3260-T-1294	17NYS yoke, 2.13"-41T spline, 5.16" end hub to center cross assy., includes item 114A.
		PD104	1	3280-U-7535	5WCS flange, 2.13"-41T spline, 8 holes 0.44" diameter on 7.25" bolt circle, 3.00" end hub to flange mounting face.
		T106, T108	1	3260-C-1537	18NYS yoke, 2.44"-44T spline, 2.94" end hub to flange mounting face.

## T-2111 SERIES MAIN CASE

ITEM	PART NAME	MODEL	QTY	PART NUMBER	DESCRIPTION
114A	Deflector-output flange/yoke	D112,	1	2297-K-6303	5.09" O.D., 2.95" I.D., 0.50" high, replaces 2297-C-627, (5.13" O.D.).
115	Oil Seal-output shaft	D110, D111, D112, D113, D116, HP100, PD102, PD103, PD104, PD106, T105, T106, T107, T108	1	A-1205-U-1529	4.00" O.D., 2.94" shaft, 0.45" wide, double lip, double case with spring, replaces A-1805A-261, (2.75" I.D.).
116	Capscrew-output shaft bearing cage	D110	8	S-2710-2	0.44"-14, 1.25"- long, 0.62" across flats, grade 8.
117	Washer-bearing cage capscrew	D110, D117	8	1229-E-1513	0.81" O.D., 0.47" I.D., 0.09" thick.
118	Cage Assy.-output shaft bearing	D110	1	A-3226-G-1255	3226-P-1238 casting, 2.12" overall length, 8 holes 0.47" diameter on 6.00" bolt circle, includes item 126 (45220).
119	Screw-name plate	All	2	9X-16	1.25" long, 0.14" diameter.
120	Name plate	All	1	2297-Y-4835	3.00" long, 1.25" high, 0.02" wide, 2 holes 0.15" diameter.
121	Capscrew-transfer case	All	20	S-2718-2	0.44"-14, 2.25" long, 0.62" across flats, grade 8.
122	Washer-transfer case capscrew	All	20	1229-E-1513	0.81" O.D., 0.47" I.D., 0.09" thick.
123	Plug-oil drain	All	1	1850-T-150	Female, square head, magnetic, 0.62" long, 0.75"-14 N.P.T.F.
124	Plug-oil suction	D102, D103 D105, D106, D107, D108, D109, D110, D111, D112, D113, D116, HP100, PD106, T102, T103, T104, T105, T107, T108	1	P-212	Female, square head, magnetic, 0.62" long, 0.75"-14 N.P.T.F., 0.55" long.
125	Plug-transfer case	All	1	P-42	Hex socket-female, 0.13"-27 N.P.T.F. thread, 0.27" long, non-magnetic.
126	Cup-output shaft bearing	D100, D102 D110	1	45220	4.13" O.D.
		D103, D107, D108, D109, D111, D112, D113, D116, D117, HP100, T103, T104, T105, T106, T107	1	39520	4.44" O.D.
		D101, D105, D106, PD100, PD101, PD102, PD103, PD104, PD106, T100, T101, T102	1	42620	5.00" O.D.

## T-2111 SERIES MAIN CASE

ITEM	PART NAME	MODEL	QTY	PART NUMBER	DESCRIPTION
127	Cone-output shaft bearing	D100, D102	1	45291	2.25" bore.
		D103, D107, D108, D111, D112, D113, D116, HP100, T105, T107	1	39580	2.25" bore.
		D101, D105, D106, PD100, PD101, PD102, PD103, PD104, PD106, T100, T101, T102	1	42687	2.13" bore.
128	Spacer-output shaft bearing to gear	D100, D101, D102	1	1244-V-1790	4.00" O.D., 2.31" I.D., 0.50" thick.
		D105, D106	1	1244-N-2042	4.00" O.D., 2.13" I.D., 0.19" thick.
129	Shaft-output	D100, D102	1	A-3297-W-1037	12.69" long, 1 spline 2.13"-41T, 1 spline 3.38"-26T, 6 dog clutch teeth 1 end, 1.69" bore same end 1.50" deep, 1.25"-12 thread 1 end, includes item 131 (1228-P-1160).
		D105, D106	1	A-3297-E-1201	9.52" long, 1 spline 3.38"-26T, 2.74" long, 1 spline 2.13"-41T, 2.28" long, 1 end has 1.25"-12 threads, other end has 6 dog teeth, includes item 131 (1228-A-53).
		PD100, PD101, PD102, PD103, PD104, PD106	1	3297-H-1048	9.00" long with 6 clutch teeth, 1 end, 1 spline 3.37"-26T, 2.74" long.
		T100, T101	1	A-3297-H-1152	5.80" long with 6 clutch teeth 1 end, 1 spline 3.37"-26T, 2.74" long, includes item 131 (1225-P-1160).
		D101	2		
130	Shaft-output	D107, D108 D117	1	3297-A-1223	15.86" long, 1 spline 2.65"-52T, 2.74" long, 2 splines 2.20"-43T.
		D109	1	3297-W-1167	14.15" long, 1 spline 2.13"-41T, 1 spline 2.65"-52T, 1 spline 2.20"-43T, 1.25"-12 thread 1 end.
		D110, D113, T103, T105 T106	1	3297-X-1168	10.60" long 1 spline 2.20"-43T, 3.50" long, 1 spline 2.65"-52T, 2.74" long.
		T102	1	A-3297-H-1204	5.80" long 1 spline 3.38"-26T, 2.74" long, 1 end has 6 dog teeth, includes item 131 (1228-A-53).
		T104	1	3297-B-1276	10.40" long 1 spline 2.20"-43T, 3.50" long, 1 spline 2.65"-52T, 2.74" long, 2 holes 0.38"- 16 tapped in 1 end of the shaft.
		HP100	1	3297-M-1365	12.05" long, 1 spline 2.20"-43T, 1 spline 2.65"-52T, 1 spline 0.88"-13T.

## T-2111 SERIES MAIN CASE

ITEM	PART NAME	MODEL	QTY	PART NUMBER	DESCRIPTION
131	Bushing-output	D100, D102 T100, T101	1	1225-P-1160	1.68" O.D., 1.50" I.D., 1.25" long with split, included in item 129 (W-1037 and H-1152).
		D101	2		
	Bearing-output shaft	D105, D106, T102	1	1228-A-53	Needle roller bearing, 1.88" O.D., 1.25" wide, included in item 129 (E-1201), and item 130 (H-1204).
132	Gear-output shaft	D100, D101, D102, D105, D106, PD100, PD101, PD103, PD104, PD106, T100, T101 T102	1	3892-R-5218	22T, helical, R.H., 3.40" major diameter-26T spline, gear face width 2.55", replaces 3892-G-4999, (gear face width 2.13").
		D103, D107, D108, D109, D110, D111, D112, D116, D117, HP100, PD102, T103, T104, T105, T106, T107, T108	1	3892-T-5220	3892-S-5219 forging, 22T helical, R.H., 2.08" major diameter- 52T spline, face width 2.55", replaces 3892-L-5004, (gear face 2.38" wide).
133	Cone-output shaft bearing	D103, D106, D111, D112, D113, D117, HP100, T105, T106, T107, T108	1	45290	2.25" bore.
		D107, D108, D109, D110, D117, T103, T104, T106	1	39580	2.25" bore.
		All others	1	42687	2.13" bore.
134	Cup-output shaft bearing	D103, D105, D106, D111, D112, D113, HP100, T103, T104, T105, T106, T107, T108	1	45220	4.13" O.D.
		D107, D108, D110, D117	1	39520	4.44" O.D.
		All others	1	42620	5.00" O.D.
135	Collar-clutch	D100, D102, D105, D106, PD100, PD101, PD102, PD103, PD104, PD106, T100, T101	1	3107-B-1120	6 jaw teeth, 3.25" O.D., 1.56" long with shift groove, 39T, 1.91" minor diameter internal gear.
		D101	2		
136	Plug-oil drain	All	1	1850-T-150	Female, square head, magnetic, 0.62" long, 0.75"-14 N.P.T.F.

## T-2111 SERIES MAIN CASE

ITEM	PART NAME	MODEL	QTY	PART NUMBER	DESCRIPTION
137	Shim-output shaft	All	3	2203-F-8872	0.003", use as required, 7.00" O.D., 5.06" I.D., 8 holes 0.47" diameter on 6.00" bolt circle 2 notches 0.80" wide on I.D. equal spaced.
			3	2203-E-8871	Same as F-8872 except thickness 0.005", use as required.
			7	2203-D-8870	Same as F-8872 except thickness 0.010", use as required.
138	Spacer-output shaft	D100, D102	1	1244-U-1789	2.75" O.D., 2.25" I.D., 3.00" long.
139	Cage Assy.-output shaft bearing	D100	1	A1-3268-D-1382	Same as J-1492 except has 3.88" bore for seal installation 1 end and different complete assembly.
		D102	1	A-3268-J-1492	3268-C-1381 casting, 5.00" long, 1 end has 8 holes 0.47" diameter on 6.00" bolt circle 1 end has 4 holes 0.63"-11, 4.00" bore 1 end for seal installation with item 134 (45220), item 169 (U-1529), and item 142 (A-2152) installed.
		D103, D105, D106, D111, D112, D113, D116, HP100, PD106, T103, T104, T105, T107, T108	1	A-3226-F-1280	3266-U-1139 casting, 8 holes 0.47" diameter on 6.00" bolt circle, 4.12" bore 1.73" overall length, includes item 134 (42620).
		D101, T100 T101, T102	1	3266-L-1104	3266-K-1103 casting, no fitted bearing, 1.08" overall length, 8 holes 0.47" diameter on 6.00" bolt circle.
		D109	1	A-3226-G-1255	3226-P-1238 casting, 2.12" overall length, 8 holes 0.47" diameter on 6.00" bolt circle, includes item 134 (45220).
140	Washer-bearing cage capscrew	D100, D101, D102, D103, D105, D106, D109, D111, D112, D113, D116, HP100, T100, T101, T102, T103, T104, T105, T106, T107, T108	8	1229-E-1513	0.81" O.D., 0.47" I.D., 0.09" thick.
141	Capscrew-output shaft bearing cage	D100, D101, D102, D103, D105, D106, D109, D111, D112, D113, D116, HP100, T100, T101, T102, T103, T104, T105, T106, T107, T108	8	S-2710-2	0.44"-14, 1.25" long, 0.62" across flats, grade 8.



## T-2111 SERIES MAIN CASE

ITEM	PART NAME	MODEL	QTY	PART NUMBER	DESCRIPTION
142	Oil Seal-output shaft	D100	1	A-1205-T-2152	3.89" O.D., 2.94" shaft , 0.58" wide, triple lip.
		D109	1	A-1205-U-1529	4.00" O.D., 2.94" shaft. 0.45" wide, double lip, double case with spring, replaces A-1805-A-261, (2.75" I.D.).
142A	Oil Seal-output shaft	D109, HP100	1	A-1205-A-2107	4.00" O.D., 3.00" shaft, 0.25" wide, single lip, full case.
143	Deflector-output flange/yoke	D102, D111, D112, HP100	1	2297-K-6303	5.09" O.D., 2.95" I.D., 0.50" high, replaces 2297-C-627, (5.13" O.D.), included in item 144 (S-1449).
144	Flange/Yoke-output shaft	D100	1	3260-R-1344	5 WCS flange, 2.13"-41T spline, 12 holes 0.44" diameter on 7.25" bolt circle, 3.00" end hub to end flange mounting face.
		D102	1	A-3260-S-1449	18 NYS yoke, 2.13"-41T spline, 5.75" end hub to center cross
		D105, D109	1	3260-D-1512	18NYS, 2.13"-41T spline, 5.94" long end hub to center cross assy.
		D106	1	17NYS34-20	17NYS yoke, 2.13"-41T spline, 5.16" end hub to center cross assembly..
		HP100	1	3260-B-1458	5WCS flange, 2.10"-41T spline, 12 holes 0.45" diameter on 7.25" bolt circle.
145	Washer-output shaft	D100, D102, D105, D106, D109, D111, D112, D113, D116, HP100, PD106	1	1229-T-1450	2.56" O.D., 1.28" I.D., 0.23" thick.
146	Nut-output shaft	D100, D102, D105, D106, D109, D111, D112, D113, D116, HP100, PD106	1	1227-K-1051	1.25"-12, 0.63" high, 1.63" across flats.
-	Silicone Gasket- 3 oz. tube	-	2	2297-Z-6656	Use as required.

## T-2111 SERIES 5450 LB-FT DECLUTCH / P.T.O.

ITEM	PART NAME	MODEL	QTY	PART NUMBER	DESCRIPTION
147	Nut-declutch shaft	D100, D102, D105, D106, D111, D112, D113, D116, HP100, PD100, PD101, PD102, PD103, PD104, PD106, T100, T101, T102	1	1227-K-1051	1.25"-12, 0.63" high, 1.63" across flats.
		D101	2		
148	Washer-declutch shaft	D100, D102, D105, D106, D111, D112, D113, D116, HP100, PD100, PD101, PD102, PD103, PD104, PD106, T100, T101, T102, T107	1	1229-T-1450	2.56" O.D., 1.28" I.D., 0.23" thick.
		D101	2		
149	Flange/Yoke-declutch	D100, PD100, PD101, PD102, PD103, PD104	1	17NYS34-20	17 NYS yoke, 2.13"-41T spline, 5.16" end hub to center cross assembly.
		D101	2		
		D102, D105	1	3260-S-1449	18 NYS yoke, 2.13"-41T spline, 5.75" end hub to center cross assembly.
		D106	1	A-3260-T-1294	17 NYS yoke, 2.13"-41T spline, 5.16" end hub to center cross assy., includes item 150.
		T100	1	3260-D-1408	18 TYS yoke, 2.13"-41T spline, 5.75" end hub to center cross assy., 4 holes 0.50"-20 in ears.
		T101, T102	1	3260-C-1407	17 TYS yoke, 2.13"-41T spline, 5.16" end hub to center cross assy., 4 holes 0.50"-20 in ears.
		PD106	1	A-3260-C-1407	17 TYS yoke, 2.13"-41T spline, 5.16" end hub to center cross assy., 4 holes 0.50"-20 in ears, available as assembly only.
150	Deflector-output flange/yoke	D106, D111, D112, T107	1	2297-K-6303	5.09" O.D., 2.95" I.D., 0.50" high, replaces 2297-C-627, (5.13" O.D.), included in item 149 (T-1294).

## T-2111 SERIES 5450 LB-FT DECLUTCH / P.T.O.

ITEM	PART NAME	MODEL	QTY	PART NUMBER	DESCRIPTION
151	Capscrew-declutch shift cover	D100, D102, D105, D106, D111, D112, D113, D116, D117, HP100, PD100, PD101, PD102, PD103, PD104, T100, T101, T102, T106	4	S-268-2	0.38"-16, 1.00" long, 0.56" across flats, grade 8.
		D101	8		
152	Washer-shift cover capscrew	D100, D102, D105, D106, D111, D112, D113, D117, HP100, PD100, PD101, PD102, PD103, PD104, T100, T101, T102	4	1229-K-1597	0.75" O.D., 0.41" I.D., 0.09" thick.
		D101	8		
153	Cover-declutch cage	D100, D102, D105, D106, PD100, PD101, PD102, PD103, PD104, PD106, T100, T101, T102	1	3266-N-1106	3266-M-1105 casting, 2.57" long, 2.57" wide, 0.38" thick, 4 holes 0.41" diameter and one 0.44"-20 threaded hole.
		D101	2		
154	Quad Ring-declutch piston	All	1	1205-N-924	1.76" O.D., 1.49" I.D., 0.14" thick.
155	Piston-declutch	D100, D102, D105, D106, PD100, PD101, PD102, PD106, T100, T101, T102	1	2230-W-1063	3.13" long, 0.78" main body diameter.
		D101	2		
156	Spring-declutch piston return	D100, D102, D105, D106, PD100, PD101, PD102, PD103, PD104, PD106, T100, T101, T102	1	2258-R-1136	1.01" O.D., 0.81" I.D., 2.00" free length.
		D101	2		
157	Fork-declutch	D100, D102, D105, D106, PD100, PD101, PD102, PD103, PD104, PD106, T100, T101, T102	1	3296-P-1186	3296-Y-1143 casting, 2.56" between jaws, 0.75" diameter shaft hole, replaces 3296-E-1097, (3296-D-1096 forging). 8 holes 0.47" diameter on 6.00" bolt circle, 7.40" long.
		D101	2		

## T-2111 SERIES 5450 LB-FT DECLUTCH / P.T.O.

ITEM	PART NAME	MODEL	QTY	PART NUMBER	DESCRIPTION
158	Setscrew-declutch fork	All	1	26X-1008	0.38"-24, 0.72" long with 0.14" diameter nylon pellet, female hex head.
159	Washer-declutch plate capscrew	D100, D102, D105, D106, D117, HP100, PD100, PD101, PD102, PD103, PD104, PD106, T100, T101, T102	4	1229-K-1597	0.75" O.D., 0.41" I.D., 0.09" thick.
		D101	8		
160	Capscrew-declutch plate	PD100, PD101, PD102, PD103, PD104, T100, T101	4	S-265-1	0.38"-16, 0.62" long, 0.56" across flats, grade 8.
		D101	8		
		D102, D105, D106, D113, HP100, PD106, T101, T102 T105	4		
161	Switch Assy.-declutch shift	D102, D105, D106, D113, D117, PD106, T101, T102, T105, T106, T107	1	A-3237-A-1041	0.56"-18 thread, 13.27" overall length.
162	Plate-declutch	D100, D102, PD101, PD102, PD103, PD104, T100, T101	1	2205-T-1008	4.25" long, 2.63" wide, 0.19" thick, 4 holes 0.41" diameter.
		D101	2		
		D102, D105, D106, PD106, T102	1		
163	Shaft-declutch	D100, D102 T100, T101	1	3297-U-1035	8.44" long, 1 spline 2.00"-39T, 1 spline 2.10"-41T, 1.25"-12 thread 1 end, 1.50" diameter other end, (use with bushing).
		D101	2		
		PD100, PD101, PD102, PD103, PD104, PD106	1	3297-J-1050	16.75" long, 1 spline 2.13"-41T, 1 spline 2.00"-39T, 1 spline 1.77"-19T, 1.25"-12 thread one end.
		D105, D106, T102	1	3297-A-1171	8.44" long, 1 spline 2.00"-39T, 1.43" long, 1 spline 2.13"-41T, 2.13" long, 1 end with 1.25"- 12 thread.
164	Cage-declutch bearing	D100, D102, D105, D106, PD100, PD101, PD102, PD103, PD104, PD106, T100, T101, T102	1	3226-Z-1144	3266-Y-1143 casting, 8 holes 0.47" diameter on 6.00" bolt circle, 4.58" long, 4.12" I.D., 4 holes 0.38"-16, 1 hole 1.75" diameter, 1.00" deep.
		D101	2		

## T-2111 SERIES 5450 LB-FT DECLUTCH / P.T.O.

ITEM	PART NAME	MODEL	QTY	PART NUMBER	DESCRIPTION
165	Washer-declutch cage capscrew	D100, D102, D105, D106, D111, D112, D113, D116, PD100, PD101, PD102, PD103, PD104, T100, T101, T102, T106, T107	8	1229-E-1513	0.81" O.D., 0.47" I.D., 0.09" thick.
		D101	16		
166	Capscrew-declutch bearing cage	D100, D102, D105, D106, PD100, PD101, PD102, PD103, PD104, T100, T101, T102, T106	8	S-2710-2	0.44"-14, 1.25" long, 0.62" across flats, grade 8.
		D101	16		
167	Bearing-declutch shaft ball	D100, D102, D105, D106, PD100, PD101, PD102, PD103, PD104, PD106, T100, T101, T102	1	1228-V-204	Ball bearing, 3.94" O.D., 2.17" bore, 0.82" wide.
		D101	2		
168	Snap Ring-declutch bearing	D100, D102, D105, D106, D112, D113, D116, D117, HP100, PD100, PD101, PD102, PD103, PD104, PD106, T100, T101, T102	1	1854-C-315	Fits 4.06" diameter groove, 0.22" wide, 0.09" thick.
		D101	2		
169	Oil Seal Assy.-declutch cage	D100, PD100, PD101	1	A-1205-S-2151	4.00" O.D., 2.94" shaft, 0.59" wide, triple lip seal.
		D101, D102, D117, PD102, PD103, PD104, T100, T101	1	A-1205-U-1529	4.00" O.D., 2.94" shaft, 0.45" wide, double lip, double case with spring.
170	Oil Seal Assy.-declutch cage	D101, D102, D105, D106, D111, D112, D113, D116, D117, HP100, PD102, PD103, PD104, PD106, T100, T101, T102, T106, T107	1	A-1205-A-2107	4.00" O.D., 3.00" I.D., 0.25" wide, single lip, full case.
-	Silicone Gasket- 3 oz. tube	All	1	2297-Z-6656	Use as required.

## T-2111 SERIES 11,000 LB-FT DECLUTCH / P.T.O.

ITEM	PART NAME	MODEL	QTY	PART NUMBER	DESCRIPTION
171	Shaft-declutch	D103	2	3297-X-1168	10.60" long, 1 spline 2.65"-52T, 1 spline 2.20"- 43T.
		D107, D108	3	A-3297-R-1162	6.19" long, 1 spline 3.12"-24T, 1 spline 2.13"-41T, 1.25"-12 thread 1 end, 2.19" bore 1.12" deep 1 end, includes item 173.
		D109, D111, D112, D113, D116, D117, T103, T104, T105, T106, T107	1		
		D110	2		
172	Collar-clutch	D103, D110	2	3107-J-1102	3.35" long, 3.88" diameter, 1 end 2.21"-43T spline, other end 3.16"-24T spline with shift fork groove on O.D.
		D107, D108	3		
		D109, D117, HP100, T103, T104, T106	1		
173	Needle Bearing-declutch shaft	D103, D110	2	1228-Z-1222	2.25" O.D., 1.88" I.D., 1.00" wide, included in item 174.
		D107, D108	3		
		D109, D117, T103, T104, T106	1		
174	Shaft Assy.-declutch	D103, D117	2	A-3297-R-1162	6.19" long, 1 spline 3.12"-24T, 1 spline 2.13"-41T, 1.25"-12 thread 1 end, 2.19" bore 1.12" deep 1 end, includes item 173.
		D117, HP100	1	3297-R-1162	6.19" long, 1 spline 3.12"-24T, 1 spline 2.13"-41T, 2.19" bore 1.20" deep 1 end.
175	Switch Assy.-decutch plate	D103	2	A-3237-A-1041	0.56"-18 thread. 13.27" overall length.
		D107, D108	3		
		D109, D110, D117, HP100, T103	1		
175A	Washer	D110, D112, D113, D117, HP100, T104, T107	1	1229-X-1558	1.03" O.D., 0.59" I.D., 0.12" thick.
175B	Plug	D110, D113, D117, HP100, T104	1	1250-A-495	0.73" long, 0.69" across hex flats with 0.56"- 18 external thread.
176	Capscrew-declutch plate	D103	8	S-266-1	0.38"-16, 0.75" long, 0.56" across flats, grade 8, replaces S-265-1, (0.62" long).
		D107, D108	12		
		D109, D117, T103, T104	4		
177	Washer-declutch plate capscrew	D103, D110	8	1229-K-1597	0.75" O.D., 0.41" I.D., 0.09" thick.
		D107, D108	12		
		D109, D117, T103, T104	4		
178	Plate-declutch	D103, D110	2	2205-B-1042	4.50" long, 3.50" wide, 0.30" thick, 4 holes 0.41" diameter, 1 hole 0.56"- 18.
		D107, D108	3		
		D109, D117, HP100, T103, T104, T105, T107	1		

## T-2111 SERIES 11,000 LB-FT DECLUTCH / P.T.O.

ITEM	PART NAME	MODEL	QTY	PART NUMBER	DESCRIPTION
179	Setscrew-declutch fork	D103, D110	2	26X-1008	0.38"-24, 0.72" long, 0.14" diameter nylon pellet, female hex head, 0.19" across flats.
		D107, D108	3		
		D109, D117, T103, T104, T106	1		
180	Fork-declutch	D103, D110	2	3296-D-1148	3296-C-1147 forging, 2.89" between jaws, 0.75" diameter shaft hole.
		D107, D108	3		
		D109, D117, T103, T104, T106	1		
181	Plug-declutch cage	D103, D110	2	P-24	0.25"-18 N.P.T.F., female, square socket, 0.41" long, non-magnetic.
		D107, D108	3		
		D109, D117, T103, T104, T106	1		
182	Quad Ring-declutch piston	D103, D110	2	1205-N-924	1.76" O.D., 1.49" I.D., 0.14" thick.
		D107, D108	3	5X-1137	1.00" O.D., 0.73" I.D., 0.14" thick.
		D109, D111, D112, D113, D116, D117, HP100, T103, T105, T106, T107	1		
183	Piston-declutch	D103, D110	2	2230-K-1155	2230-J-1154 forging, 4.17" long, 0.19" diameter thru hole, 0.16" wide seal groove on 2.24" O.D.
		D107, D108	3		
		D109, D117, T103, T104, T106			
184	Quad Ring-declutch piston	D103, D110	2	5X-1138	2.26" O.D., 1.98" I.D., 0.14" thick.
		D107, D108	3		
		D109, D117, HP100, T103, T104, T106	1		
185	Spring-declutch piston return	D103, D110	2	2258-K-1233	1.60" O.D., 0.15" bore diameter, 4 active coils, 4.25" free length.
		D107, D108	3		
		D109, D117, T103, T104, T106	1		
186	Cover-declutch cage	D103, D110	2	2205-C-1043	3.00" long, 2.60" wide, 0.38" thick, 4 holes 0.41" diameter, 1 hole 0.56"-18.
		D107, D108	3		
		D109, D117, HP100, T103, T104, T106	1		
187	Washer-shift cover capscrew	D103, D110	8	1229-K-1597	0.75" O.D., 0.41" I.D., 0.09" thick.
		D107, D108	12		
		D109, D117, T103, T104, T107	4		
188	Capscrew-declutch shift cover	D103, D110	8	S-268-2	0.38"-16, 1.00" long, 0.56" across flats, grade 8.
		D107, D108	12		
		D109, D117, HP103, T103, T104, T106	4		

## T-2111 SERIES 11,000 LB-FT DECLUTCH / P.T.O.

ITEM	PART NAME	MODEL	QTY	PART NUMBER	DESCRIPTION
189	Switch Assy.-declutch shift	D103, D110	2	A-3237-A-1041	0.56"-18 thread, 13.27" overall length.
		D107, D108	3		
		D109, D117, T103, T104	1		
190	Cage-declutch bearing	D107, D108	2	3226-V-1218	3226-U-1217 casting, 8.67" overall length, 4.87" diameter barrel, flange with 8 holes 0.47" diameter, includes piston hole 2.75" diameter and 2.66" deep, includes item 126 (39520), item 172, 193, and 194.
		D109, D111, D112, D113, D117, HP100, T103, T105, T106, T107	1	A1-3226-V-1218	
		D110	2		
		D103, D111, D112, D113, D116, D117, HP100, T105, T106, T107	2		
191	Washer-declutch cage capscrew	D103, D110	16	1229-E-1513	0.81" O.D. 0.47" I.D., 0.09" thick.
		D107, D108	24		
		D109, D117, HP100, T103, T104	8		
192	Capscrew-declutch brg. cage	D103, D110	16	S-2710-2	0.44"-14, 1.25" long, 0.62" across flats, grade 8.
		D107, D108	24		
		D109, D117, HP100, T103, T104	8		
193	Bearing-declutch shaft ball	D103, D110	2	1228-N-1262	Ball, 3.94" O.D., 2.17" I.D., 0.82" wide, included in item 190.
		D107, D108	3		
		D109, D117, T103, T104, T106	1		
194	Snap Ring-declutch bearing	D103, D110	2	1854-C-315	Fits 4.06" diameter groove, 0.22" wide, 0.09" thick, included in item 190.
		D107, D108	3		
		D109, T103, T104, T106	1		
195	Oil Seal Assy.-declutch cage	D103, D110	2	A-1205-U-1529	4.00" O.D., 2.94" shaft, 0.45" wide, double lip, double case with spring.
		D107, D108	3		
		D109, D117, T103, T104	1		
196	Oil Seal Assy.-declutch cage	D103, D110	2	A-1205-A-2107	4.00" O.D., 3.00" I.D., 0.25" wide, single lip, full case.
		D107, D108	3		
		D109, D117, T103, T104	1		
197	Deflector-declutch yoke	D103, D107 D117	2	2297-K-6303	5.09" O.D., 2.95" I.D., 0.50" high, replaces 2297-C-627, (5.13" O.D.), included in item 198.
		T104	1		
198	Flange/Yoke-declutch	D103	1	A-3260-T-1294	17 NYS yoke, 2.13"-41T spline, 5.16" end hub to center cross assy., includes item 197.
		D103, D107	1	3260-B-1510	155TYS yoke, 2.13"- 41T spline, 4.50" from end hub to center cross assy.
		D107, D117 D108	1 2	A-3260-D-1460	17NYS yoke, 2.13"-41T spline, 2.50" spline length, includes item 197.

(Continued)



## T-2111 SERIES 11,000 LB-FT DECLUTCH / P.T.O.

ITEM	PART NAME	MODEL	QTY	PART NUMBER	DESCRIPTION
198	Flange/Yoke-declutch	D107, D110	1	A-3260-D-1512	18NYS yoke, 2.13"-41T spline, 5.94" long end hub to center cross assy., includes item 197.
		D108, D110	1	3260-C-1511	5WCS flange, 2.10"-41T spline, 12 holes 0.48" in diameter on 7.25" bolt circle, 3.19" long end hub to flange mounting face.
		D109, T103	1	3260-D-1512	Same as A-3260-D-1512 less item 197.
		T104	1	A-3260-B-1536	17TYS yoke, 2.13"-41T spline, 5.35" end hub to center cross assy., includes item 197.
		T105, T106	1	3260-C-1537	18TYS yoke, 2.28"-44T spline, 4 holes 0.50"-20 in ears, 2.96" end hub to center cross assy.
199	Washer-declutch shaft	D103, D110	2	1229-T-1450	2.56" O.D., 1.28" I.D., 0.23" thick.
		D107, D108	3		
		D109, D117, T103, T104	1		
200	Nut-declutch shaft	D103, D110	1	1227-K-1051	1.25"-12, 0.63" high, 1.63" across flats.
		D107, D108	3		
		D109, D117, T103, T104	1		
-	Silicone Gasket- 3 oz. tube	All	1	2297-Z-6656	Use as required.
201	Fitting/Filter Assy.	D103, D107, D108, D110, D113, D117, HP100, T103, T106, T108	1	A-2206-D-56	0.25"-18 N.P.T.F. female thread, fitting is 1.17" long with 1.12" across flats, includes screen 2297-S-3841, (4.00" long, 0.81" O.D.).
202	Fitting-inlet tube to filter	D103, D117, T103, T106, T108	1	A-1898-U-645	Fitting for 0.38" diameter tube, male end 0.25" N.P.T.F., 1.06" long, female end 0.84" long.
		D107, D108, D110, D113, D117, HP100	1	1898-J-868	1.02" long, 0.75" cross hex flats, 0.28" I.D., thru hole, 0.25"-18 N.P.T.F. male thread and 0.63"-18 thread.
203	Button-pump drive	D103, D107, D108, D110, D113, D116, D117, HP100, T103, T106	1	2297-A-6423	0.94" long, 1 end has 0.26" slot, 0.55" body diameter, included in item 105 (Z-5226).
204	Coupling-oil pump	D103, D107, D108, D110, D113, D117, HP100, T103, T106, T108	1	2207-W-1011	0.57" long, 0.56" diameter, 1 end has 0.24" wide tang, other end has 0.17" wide slot.
205	Pump Assy.-oil	D103, D107, D108, D110, D113, D117, HP100, T103, T106, T108	1	A-3303-Q-1005	3.16" long, 2.75" wide, 4 holes 0.34" diameter, 2 ports 0.38"-18 N.P.T.F., available as assembly only.

## T-2111 SERIES OIL PUMP

ITEM	PART NAME	MODEL	QTY	PART NUMBER	DESCRIPTION
206	Washer-oil pump to idler cage	D103, D107, D108, D110, D113, D117, HP100, T103, T106, T108	4	1229-E-1669	0.62" O.D., 0.34" I.D., 0.06" thick.
207	Capscrew-oil pump to idler cage	D103, D107, D108, D110, D113, D117, HP100, T103, T106, T108	4	S-2528-1	0.31"-18, 3.50" long, 0.50" across flats, grade 8.
208	Fitting-oil pump Assy.	D103, D107, D108, D110, D113, D117, T103, T106, T108	1	2206-W-1037	0.38"-18 N.P.T.F. male thread, 1.00" overall length, female end has 0.63"-18 thread, 0.75" across flats.
209	Tube Assy.-lube outlet	D103, D108, D110	1	A-2296-C-1043	0.38" diameter tube, 16.50" total length, includes 2 fittings 1898-G-241.
		D107, D113 D117, HP100	1	A-3196-B-1068	0.75" O.D., 0.38" I.D., approximately 23.69" long with 2 fittings 0.63"-18 UNF ( 1 each end).
		T103, T106	1	A-2296-V-1036	0.38" diameter copper tube, total length 17.90", includes two fittings (1898-G-241), available as assembly only.
		D117	1	A-2296-U-1061	11.43" long, 0.38" x 0.04" steel tubing, 45 degree double flange, available as assembly only.
209A	Clamp	D113, D117, HP100	2	2257-D-1096	0.49" diameter hole, 0.05" thick, 0.88" wide, 0.62" diameter
		HP100	1	2257-M-1183	0.51" diameter hole, 0.05" thick, 1.00" wide, 0.62" diameter
210	Fitting-outlet tube to cage	D103, D107, D108, D110, D113, D117, HP100	1	1898-H-242	Male end 1.25" long, 0.25" N.P.T.F., female end 0.63"-18, 0.73" across flats.
211	Fitting-oil pump Assy.	D103, D107, D108, D110, D113, HP100, T103	1	2206-W-1037	0.38"-18 N.P.T.F. male thread, 1.00" overall length, female end has 0.63"-18 thread, 0.75" across flats.
212	Tube Assy.-lube inlet	D103, T108	1	A-2296-V-1036	0.38" diameter copper tube, total length 17.90", includes two fitting 1898-G-241, available as assembly only.
		D107, D117	1	A-2296-C-1043	0.38" diameter tube, 16.50" total length, includes 2 fittings (1898-G-241).
		D108, D110	1	A-3196-B-1068	0.75" O.D., 0.38" I.D., approximately 23.69" long with 2 fittings 0.63"- 18 UNF (1 each end), available as assembly only.
		T103, T106, T108	1	A-2296-W-1037	0.38" diameter steel tubing with 21.80" developed length, includes 2 fittings (1898-G-241), available as assembly only.

(Continued)

## T-2111 SERIES OIL PUMP

ITEM	PART NAME	MODEL	QTY	PART NUMBER	DESCRIPTION
212	Tube Assy.-lube inlet	D117	1	A-2296-V-1062	0.38" diameter steel tubing, 17.59" before bending, includes (1898-G-241), available as assembly only.
213	Cage-brg. transfer case	HP100	1	A-3226-D-1304	8 holes 0.47" diameter thru 6.00" bolt circle tap drill 1.13" deep, 0.50"-13 UNC, 0.88" deep 4 holes, 7.00" O.D., 2.38" I.D.
214	Washer-cage capscrew	HP100	1	1229-E-1513	0.81" O.D., 0.47" I.D., 0.09" thick.
215	Screw	HP100	1	SP1044	12 pt. ferry head, 1.25" length, 0.44"-14 UNC, grade 8.
216	Cage-brg. transfer case	D116	1	A-3226-V-1218	4.87" diameter barrel, flange with 8 holes 0.47" diameter on 6.00" bolt circle.
217	Washer-cage capscrew	D116, D117	1	1229-E-1513	0.81" O.D., 0.47" I.D., 0.09" thick.
218	Capscrew output shaft brg	D116, D117	4	S-2710-2	0.44"-14, 1.25" long, 0.62" across flats, grade 8.

# NUMERICAL PARTS LISTING

PART NUMBER	PAGE	PART NUMBER	PAGE	PART NUMBER	PAGE
3X-374	9	1229-F-2814	11,32	2247-M-1157	14
5X-1137	27,53	1229-F-4582	17	2257-D-1096	56
5X-1138	53	1244-R-1760	18,25	2257-M-1183	56
9X-16	23,43	1244-S-1761	13,29	2258-R-1136	27,49
10X-507	9,11,13,29	1244-U-1789	17,37,46	2258-K-1233	53
10X-1438	11,29	1244-V-1790	23,38,44	A-2296-V-1036	56,57
26X-237	11,32	1244-S-1813	32	A-2296-W-1037	56
26X-1008	27,50,53	1244-N-2042	18,44	A-2296-C-1043	56
302-Z-676	29	1250-A-495	52	A-2296-U-1061	56
372-X-206	14	1779-Z-260	14,29	2296-W-1063	42
372-E-213	14	A-1805-A-261	16,22,25	2297-C-627	14,15,19,22, 26,29,39
1199-J-894	42	A-1805-P-536	9,14	2297-Y-4835	23,43
A-1199-C-1043	18,38	1844-U-411	11,29	2297-K-6303	15,19,22,27, 34,39,43,47, 48,54
1199-Y-3067	27	1846-Z-312	9,11,16,35	2297-A-6423	55
1205-N-924	27,49,53	1850-T-150	20,21,23,25, 31,42,43,45	2297-Z-6656	26,28,47,51,55
A-1205-U-1529	10,15,19,22, 25,28,29,34, 39,43,47,51,54	1854-S-149	11,32	2710-U-151	14,29
A-1205-A-2107	10,14,16,19, 22,28,30,34, 39,47,51,54	1854-Z-182	11,31	2758-A-53	9,11,13,29
A-1205-S-2151	39,51	1854-C-315	28,51,54	2847-Z-312	15,19,22,26
A-1205-T-2152	29,47	1898-S-201	42	2847-C-367	15,19,22,26
A-1205-S-2281	9,14,16,19	1898-H-216	18,38	3107-G-1099	25
1225-P-1160	24,37,45	1898-H-242	56	3107-J-1102	52
1227-Z-936	13,15,20,21,26	1898-A-261	42	3107-B-1120	25,45
1227-J-946	33,40	A-1898-U-645	55	A-3196-B-1068	56
1227-K-1051	13,15,20,21, 26,27,29,33, 40,42,47,48,55	1898-C-835	42	3198-D-30	32
1228-A-53	17,24,45	1898-D-836	42	3219-H-4064	29
1228-V-204	10,28,51	1898-J-868	55	3219-K-4743	13
1228-N-1262	54	2000-J-1362	13	A-3219-K-4743	13
1228-Z-1222	52	2203-D-8870	9,11,18,20, 25,38,41,46	A-3226-Z-1040	23,25
1229-T-1450	13,15,20,21, 26,27,29,33, 40,42,47,48,55	2203-E-8871	9,11,18,20, 25,38,41,46	A-3226-F-1046	14,30
1229-U-1503	14,29,30	2203-F-8872	9,11,18,20, 25,38,41,46	3226-H-1048	14
1229-E-1513	9,10,11,12,14, 16,19,20,21, 22,23,25,28, 31,32,34,39, 40,41,42,43, 46,51,54,57	2203-W-9851	11,31	A-3226-H-1048	18
1229-X-1558	52	2203-X-9852	11,31	A-3226-K-1051	16,20,23
1229-K-1597	9,10,12,13,27, 49,50,52,53	2203-Y-9853	11,31	A-3226-X-1142	16,18,23,35,38
1229-E-1669	56	2203-Z-9854	11,31	3226-Z-1144	28,50
1229-R-1734	33,40	2203-A-9855	11,31	A-3226-E-1201	14,18
1229-K-2143	13,15,21,26	2203-B-9856	11,31	A-3226-J-1206	41
1229-K-2412	20	2205-T-1008	27,50	3226-V-1218	28,54
		2205-Y-1039	27,50	A-3226-V-1218	57
		2205-B-1042	52	A1-3226-V-1218	54
		2205-C-1043	53	A-3226-H-1230	18,23,38
		A-2206-D-56	55	A-3226-G-1255	16,23,35,38, 43,46
		2206-W-1037	56	3226-F-1280	25
		2207-W-1011	55	A-3226-F-1280	16,18,20,21, 23,25,35,38, 42,46
		2230-W-1063	27,49	A-3226-D-1304	57
		2230-K-1155	53	A-3237-A-1041	50,52,54
		2240-N-5162	13		
		2240-Y-5381	29		

# NUMERICAL PARTS LISTING

<b>PART NUMBER</b>	<b>PAGE</b>	<b>PART NUMBER</b>	<b>PAGE</b>	<b>PART NUMBER</b>	<b>PAGE</b>
A-3238-T-1008	31	A-3280-J-2454	6,22,26	A2-3722-F-422	9,13
A-3260-A-79	6,15,22,26	A2-3280-J-2454	15,19	A2-3722-G-501	9,13
3260-X-1038	6,13	3280-U-7535	6,29,42	A-3736-K-375	14,29
A-3260-Y-1039	6,15,22	A-3280-U-7535	40	A-3736-D-472	14
3260-T-1294	19,27	3280-Y-8267	6,13	A-3787-N-14	13,29
A-3260-T-1294	6,21,33,40, 42,48,54	3290-M-1001	16,18	A-3787-Q-17	13
3260-R-1344	6,39,47	3290-F-1020	35,37	3819-E-525	13
A-3260-Z-1378	6,15	3290-N-1054	35,38	3891-Q-1629	32
3260-C-1407	48	3290-J-1076	38	3892-Z-3588	32
A-3260-C-1407	6,34,40,48	A-3290-J-1076	37	3892-B-4838	17,24
3260-D-1408	48	3296-D-1148	53	3892-D-4840	21
A-3260-D-1408	6	3296-P-1186	27,49	3892-B-4994	17,24
3260-P-1420	33,40	3297-U-1035	28,50	3892-C-4995	17,24
A-3260-P-1420	6,33,40	3297-N-1002	17,24	3892-Q-5217	41
3260-Q-1421	34,40	3297-P-1004	6,24	3892-R-5218	37,45
A-3260-Q-1421	6,33,40	3297-N-1002	6	3892-T-5220	37,45
A-3260-U-1425	6	3297-U-1035	6	3892-Z-5226	41
A-3260-V-1426	6	A-3297-W-1037	6,36,44	A-3892-Z-5226	41
3260-S-1449	48	A-3297-A-1041	24,27	3892-V-5352	41
A-3260-S-1449	6,33,40,47	3297-B-1042	6,17,24	A-3892-V-5352	41
3260-X-1454	15,27	3297-F-1046	6,36	3897-N-1990	6
A-3260-X-1454	6,15,19	3297-H-1048	44	LW-168	9,13,29
3260-B-1458	6,47	3297-J-1050	6,50	N-16-1	9,11,13,29
3260-D-1460	29	3297-K-1051	6,31	NL-27-1	9,11,20,41
A-3260-D-1460	6,33,54	3297-Z-1144	6,17,24	P-24	53
3260-B-1510	6,54	A-3297-H-1152	44	P-26	16,18,35,38
3260-C-1511	6,34,40,42,55	3297-K-1155	6,36	P-42	16,18,20,23, 35,37,41,43
3260-D-1512	33,47,55	3297-R-1162	52	P-212	20,21,23,32, 41,42,43
A-3260-D-1512	6,33,55	A-3297-R-1162	6,52	RV-875	13
3260-G-1515	6,22,27	3297-W-1167	6,36,44	RV-876	13,29
A-3260-B-1536	55	3297-X-1168	44,52	S-166-D1	9,13
3260-C-1537	42,55	A-3297-Z-1170	24	S-265-1	12,50
A-3260-U-1633	15,22	3297-A-1171	6	S-266-1	12,27,50,52
3260-V-1686	40	A-3297-B-1172	6,17,24	S-268-1	17
3264-V-100	14,29	3297-A-1171	28,50	S-268-2	10,12,27,49,53
3264-W-101	29	A-3297-E-1201	44	S-269-1	10
A-3266-Z-1040	18	3297-F-1202	6,36	S-289A-1	14
A-3266-K-1051	21	A-3297-H-1204	44	S-2528-1	56
3266-L-1104	23,25,46	3297-J-1206	6,17,24	S-2710-1	42
3266-N-1106	27,49	3297-K-1207	6,17	S-2710-2	9,10,11,12,14, 16,19,20,21, 22,25,28,31, 32,34,39,40, 46,51,54,57
3266-A-1119	32	3297-A-1223	44	S-2718-1	9,11,23
A-3266-X-1142	25	3297-B-1276	44	S-2718-2	43
A-3266-F-1280	41	3297-G-1281	17	S-21012-2	9,14
A1-3268-D-1382	46	3297-K-1285	17	S-21014-1	30
3268-P-1394	31	3297-L-1286	17	SP1044	57
A-3268-V-1426	31	3297-M-1365	44		
A-3268-Y-1481	31	3297-Q-4827	31		
A-3268-J-1492	34,46	A1-3298-H-1048	32		
3280-U-2205	19	A-3303-Q-1005	55		
A-3280-U-2205	6,15,22,26	A2-3722-D-420	11		
		A3-3722-D-420	29		

# NUMERICAL PARTS LISTING

PART NUMBER	PAGE	PART NUMBER	PAGE	PART NUMBER	PAGE
WA-39	14,29	KIT T-2111-1	8,11		
3WCS22-79	6	KIT T-2111-2	8,11		
5WCS32-50	6	KIT T-2111-3	8,11		
5WCS33-3	6	KIT T-2111-4	8,11		
5WCS34-7	6	KIT T-2111-5	8,12		
5WCS34-8	6				
5WCS34-9	6				
17NYS32-63A	6,19,26				
17NYS34-20	15,21,26,29, 33,42,47,48				
17NYS34-20A	6				
17NYS34-29A	6				
17TYS34-38A	6				
17TYS36-59A	6				
18NYS34-4A	6				
18NYS34-5A	6				
18TYS34-4A	6				
18TYS36-17A	6				
72NYS36-97A	6				
82NYS36-124A	6				
85WBY34-4	6				
148NYS28A	6				
148TYS34-3	6				
155TYS32-23A	6,19				
155TYS34-6A	6				
155TYS34-7	6				
390	11,31				
394A	11,31				
3720	16,18,20,21, 23,24				
3780	16,17,21,23,24				
39520	37,43,45				
39580	37,44,45				
42620	11,16,23,24, 36,43,45				
42687	16,23,24,36, 44,45				
45220	11,16,18,20, 21,23,24,36, 37,41,43,45				
45285	16,18,20,21, 23,24				
45290	11,16,17,23, 24,36,37,41,45				
45291	37,44				
45687	11				
KIT T-215-1	7,9				
KIT T-215-2	7,9				
KIT T-215-3	7,9				
KIT T-215-4	7,9				
KIT T-215-5	7,10				

# NOTES

# NOTES



**CORRECTIONS? ADDITIONS?**

**DELETIONS? COMMENTS?**

**WE WANT TO KNOW!**

Just fill out the card, tear it out and mail it. The postage is already paid.

In regard to Meritor Parts Catalog PB-90199 – T-215 and T-2111 Transfer Cases,  
revised 11/94:

**PAGE #:** \_\_\_\_\_ **PART NUMBER:** \_\_\_\_\_

**APPLICATION:** \_\_\_\_\_

**COMMENTS:** \_\_\_\_\_

\_\_\_\_\_

\_\_\_\_\_

\_\_\_\_\_

**NAME:** \_\_\_\_\_

**COMPANY:** \_\_\_\_\_

**PHONE NUMBER:** \_\_\_\_\_



NO POSTAGE  
NECESSARY  
IF MAILED  
IN THE  
UNITED STATES

---

**BUSINESS REPLY MAIL**

FIRST CLASS      PERMIT NO. 109      TROY, MI

---

POSTAGE WILL BE PAID BY ADDRESSEE



ARVINMERITOR  
COMMERCIAL VEHICLE AFTERMARKET  
7975 DIXIE HIGHWAY  
FLORENCE, KY 41042

**ATTENTION:  
CATALOG DEPT.**





**ArvinMeritor**<sup>TM</sup>

**Meritor Heavy Vehicle Systems, LLC**  
2135 West Maple Road  
Troy, MI 48084 USA  
248-435-1085  
800-535-5560 (North America only)  
arvinmeritor.com



Information contained in this publication was in effect at the time the publication was approved for printing and is subject to change without notice or liability. Meritor Heavy Vehicle Systems, LLC, reserves the right to revise the information presented or discontinue the production of parts described at any time.

ArvinMeritor do Brasil Ltda.	ArvinMeritor Commercial Vehicle Systems Saint-Etienne S.A.
Av. João Batista, 824	4, Rue Jean Servanton
06097-900 Osasco-SP	Boite Postale 656
BRAZIL	42042 Saint Etienne Cedex 1
(55-11) 7084-6510	FRANCE
Fax: (55-11) 7084-6600	(33) 477.92.88.00 Fax: (33) 477.92.88.93

PB-90199  
Revised 11-94  
47865/24240

Copyright 1994 ArvinMeritor, Inc.

All Rights Reserved

Printed in the USA