

DRIVELINE MAINTENANCE MANUAL

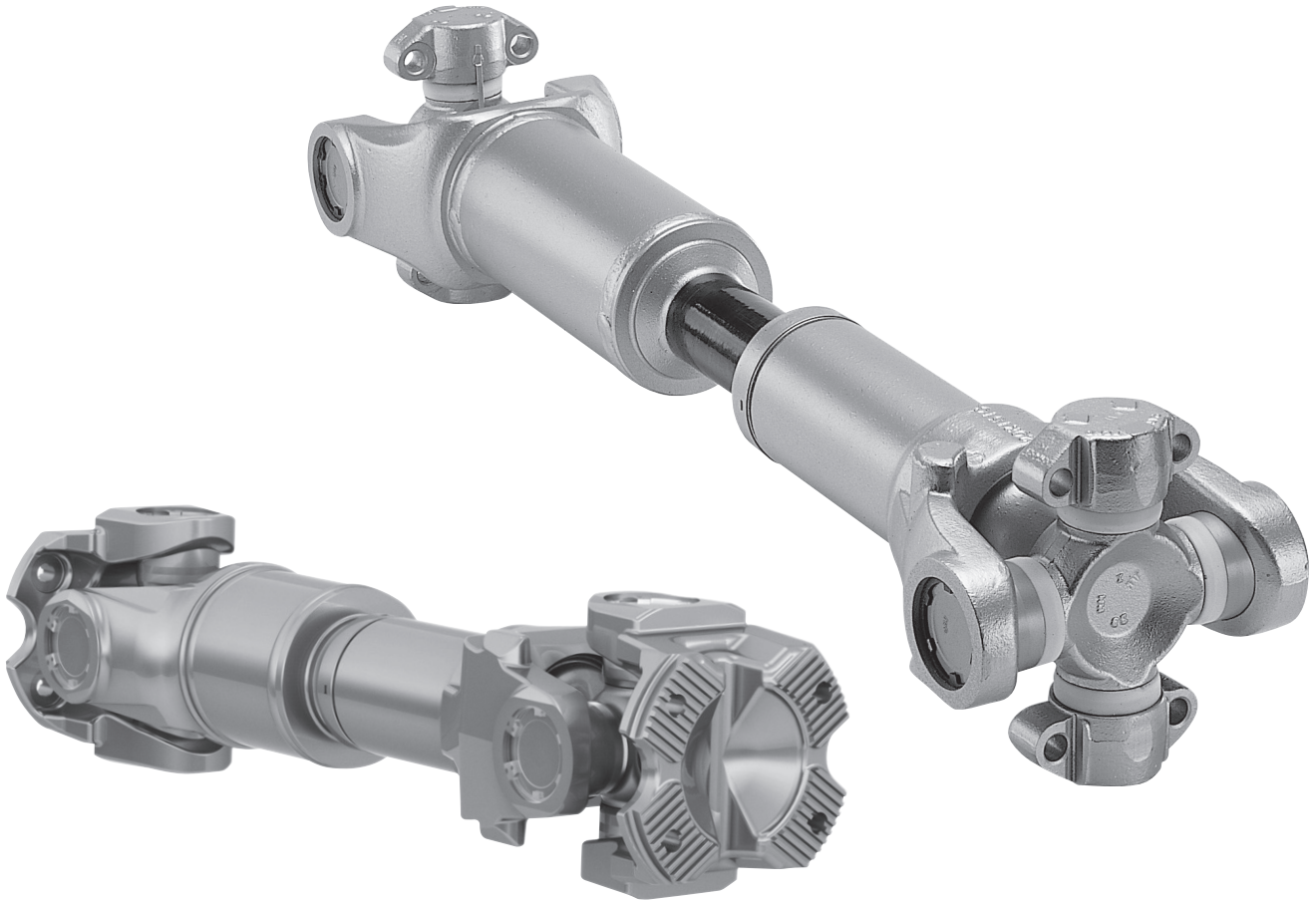

Service Notes

About this Manual

This manual provides maintenance and service procedures for Meritor RPL Series Permalube™, Wing-Style Permalube™, Full-Round, Easy Service™, Wing-Style and 155R Series drivelines.

How to Obtain Additional Maintenance, Service and Product Information

Visit [Literature on Demand on meritor.com](https://www.meritor.com/literature-on-demand) to access and order the following publications.

- [Technical Bulletin TP-9980, RPL Series Permalube™ Driveline Universal Joint Inspection Guidelines and Procedures](#)
- [Technical Bulletin TP-2243, Center Bearing Inspection/Installation Guidelines](#)
- [Parts Book PB-9895, Meritor Aftermarket Driveline Components](#)

Additional information is also available at [meritorbullpen.com](https://www.meritorbullpen.com).

Contact the Meritor OnTrac™ Customer Service Center at 866-668-7221 (US and Canada) between 7:30 AM and 10:00 PM ET Monday through Friday, and between 9:00 AM and 6:00 PM ET on Saturday; 001-800-889-1834 (Mexico); or visit our website: www.meritor.com/warranty.

If Tools and Supplies are Specified in This Manual

Contact Meritor's Commercial Vehicle Aftermarket at 888-725-9355.

For assistance with parts, you may also contact the Meritor Parts Center in Florence, KY at 859-525-3500 or CustCareCntr.Florence@Meritor.com.

Table of Contents

About this Manual	ii		
How to Obtain Additional Maintenance, Service and Product Information	ii		
If Tools and Supplies are Specified in This Manual ..			
Section 1: Safety Information	1	Section 5: RPL Series Permalube	14
Hazard Alert Messages	1	RPL10 and RPL14 Series Permalube Procedures	14
Safety Precautions	1	Removal	14
Section 2: Driveline.....	2	Disassembly	15
Standard Driveline	2	Assembly.....	16
Two- and Three-Piece Driveline	3	Installation	17
Section 3: Introduction.....	5	RPL20, RPL25 and RPL25SD Series Permalube Procedures	19
Description	5	Removal	20
Section 4: Inspection	7	Disassembly	22
Driveline	7	Assembly.....	23
End Yokes or Flanges.....	7	Installation	24
Universal Joints.....	8	RPL35 and RPL35SD Series Permalube Procedures	30
Center Bearings	9	Removal	30
Slip Yoke.....	10	Assembly.....	34
Permalube™ Drivelines.....	11	Installation	36
		Section 6: Full-Round	39
		Removal	39
		Disassembly	39
		Installation	40
		Lubrication.....	42
		Section 7: Wing-Style Permalube	44
		Removal	44
		Installation	44
		Lubrication.....	45

Section 8: Easy Service	46
Removal	46
Disassembly	46
Assembly	47
Installation	48
Lubrication.....	49
Section 9: 155R Series Slip Drive Shaft Assembly 50	
Removal	50
Disassembly	51
Assembly	52
Installation	53
Lubrication.....	55
Section 10: Center Bearing Removal and Installation 56	
Center Bearings on Meritor Drivelines.....	56
Removal	57
Disassembly	57
Installation	60
Coupling Shaft	60
Section 11: Lubrication.....	62
Maintenance.....	62
Driveline Inspection	62
Section 12: Torque Specifications.....	65
Driveline	65
Section 13: Troubleshooting	66
Special Tools.....	66
Troubleshooting.....	66

Section 14: Measuring and Recording Driveline Angles	73
Special Tools.....	73
Overview	73
Data Gathering Worksheet	73
Measure	75
Adjustment	78
Driveline Angle Analysis Program.....	79
Measuring and Recording Driveline Angles: Plan View	81
Section 15: Driveline Balance Weight	84
Section 16: Special Tools	85
Section 17: Glossary	90
Important Information	91

Safety Information

Hazard Alert Messages

Read and observe all hazard alert messages in this publication.

DANGER

Indicates imminent danger. Failure to follow this instruction will result in death or serious injury.

WARNING

Indicates a possibly impending danger. Failure to follow this instruction can result in death or serious injury.

CAUTION

Indicates a hazardous situation or unsafe practice which, if not avoided, could result in injury or damage to components.

Safety Precautions

Before performing service and maintenance procedures, read and understand the following safety precautions.

DANGER

- Before starting any work on the vehicle, carefully read and understand all instructions and hazard alert messages provided in this publication. Failure to follow procedures and alerts as directed can result in death, serious injury and damage to components.
- Procedures may only be performed by qualified professionals who are trained and certified in vehicle service. Death or serious personal injury and damage to components can result.
- Only perform work on a flat, level surface in a well-lit, ventilated area. Death or serious personal injury and damage to components can result.
- Follow all safety instructions and service guidelines established at the service facility where work is being performed. Death or serious personal injury and damage to components can result.

DANGER

- Use only the recommended tools for service. Follow all safety guidelines and instructions provided by the tool manufacturer. Failure to do so can result in death or serious injury and damage to components.
- Park the vehicle on a level surface. Block the wheels to prevent the vehicle from moving. Support the vehicle with safety stands. NEVER work under a vehicle supported only by jacks. Jacks can slip and fall over. Failure to use safety stands can result in death or serious personal injury and damage to components.

WARNING

- Always wear proper eye protection and other appropriate personal protective equipment when performing procedures.
- Never wear loose clothing such as neck ties and jewelry such as necklaces, watches and rings when working on a vehicle. Always tie long hair back. Loose clothing, hair and jewelry can catch on parts, resulting in serious injury.
- Turn the engine Off and remove the ignition key before working on a vehicle. Contact with moving parts can result in serious injury.
- After operating a vehicle, allow the vehicle to cool down before performing service. Coming into contact with hot parts and fluids can cause burns and serious injury.
- Drain the air completely from the air system before working on any connected air lines or components.
- Never disconnect or connect an air line containing pressurized air. The air line can whip around or project debris, resulting in personal injury.
- Use only Meritor® brand replacement parts, components and kits. Use of unauthorized parts can result in damage or injury, and void the Meritor warranty.
- Always ensure all components and systems are in correct operating condition before returning the vehicle to service.

2 Drivelines

Driveline

Standard Driveline

The typical driveline system is shown in Figure 2.1. On a standard slip shaft assembly, the splined shaft points forward in the vehicle. For a typical interaxle driveline, refer to Figure 2.3.

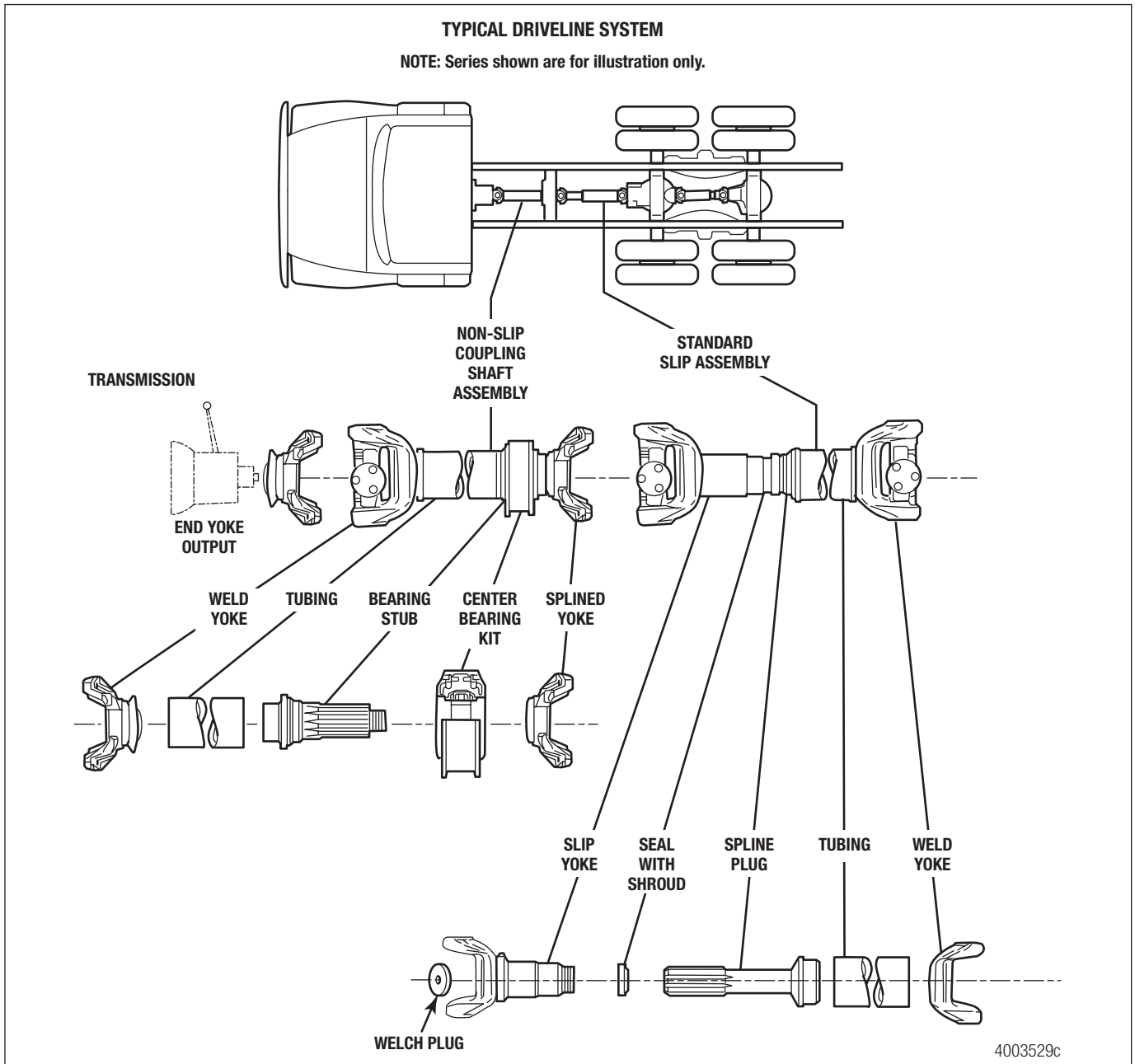

Figure 2.1

Two- and Three-Piece Driveline

A two- or three-piece driveline is comprised of one or two non-slip coupling shafts followed by a standard slip drive shaft assembly. The non-slip coupling shafts are always positioned in front of the slip shaft. Figure 2.2.

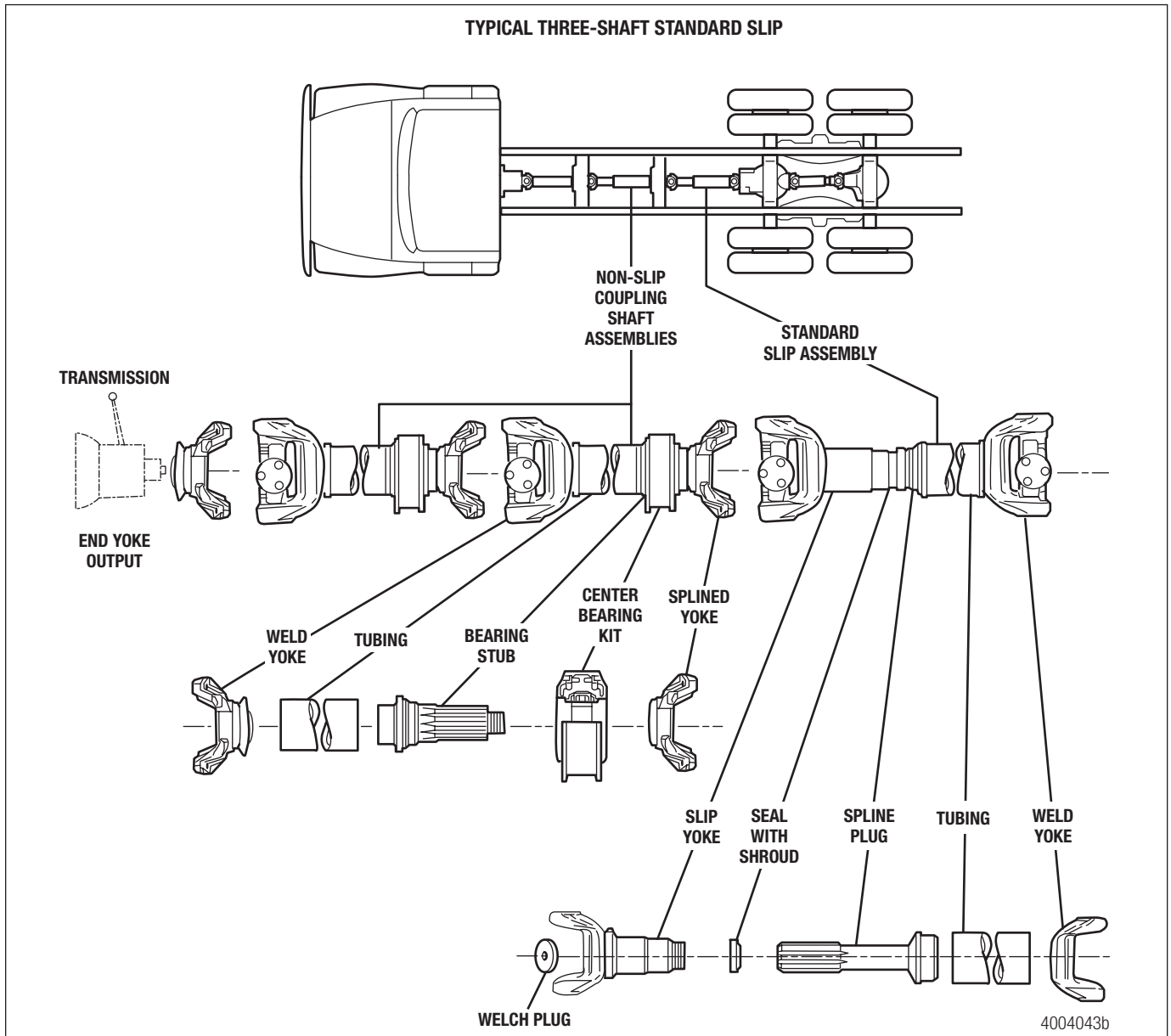

Figure 2.2

2 Drivelines

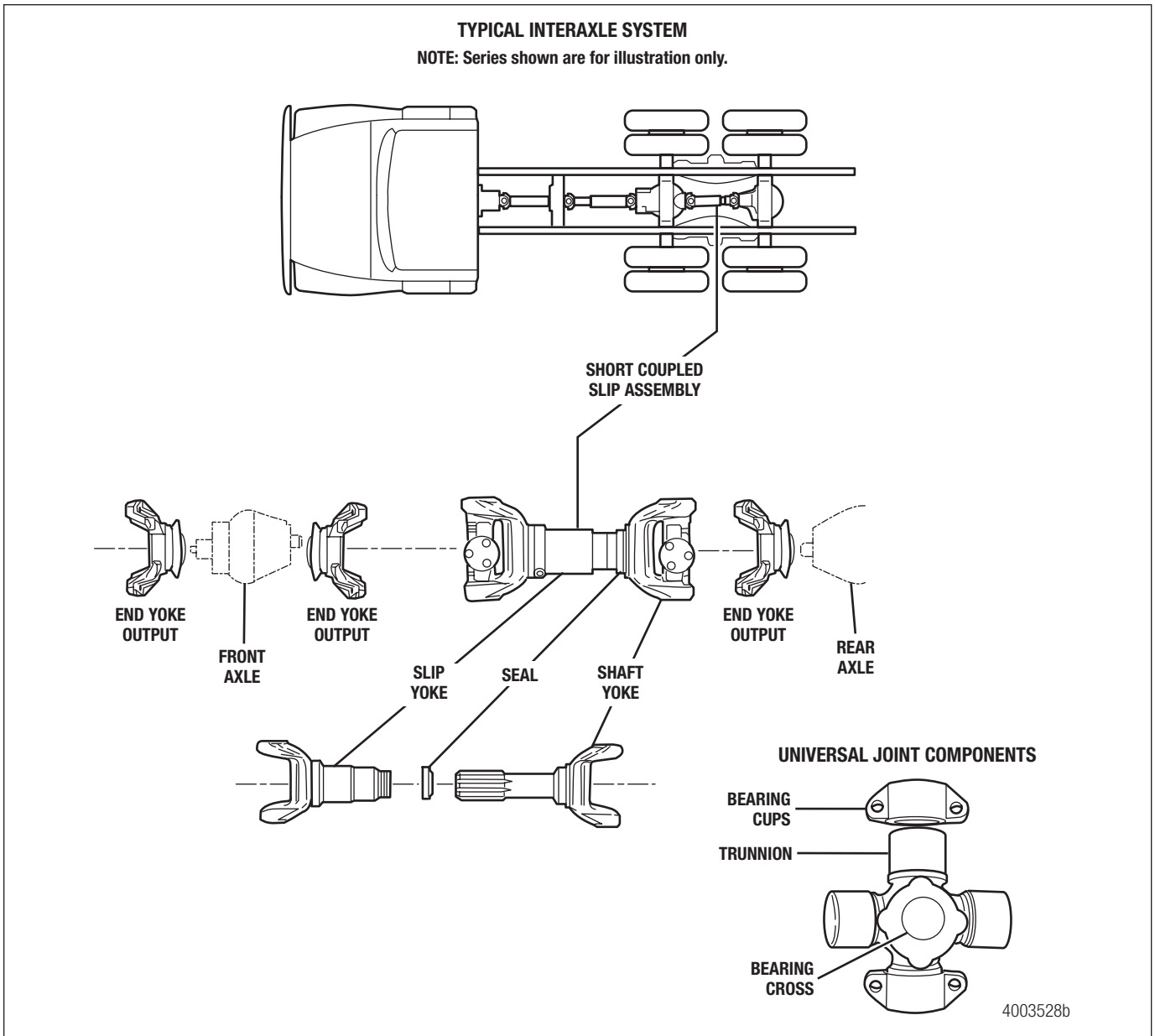

Figure 2.3

Introduction

Description

RPL Series Permalube™ (Non-Greaseable)

The Meritor RPL Series Permalube non-greaseable driveline is permanently lubricated and sealed at the factory and does not require lubricant. RPL10 and RPL14 series drivelines are similar to the 155R series driveline except they do not require lubrication. Figure 3.1. RPL20, RPL25 and RPL25SD series drivelines have arrows on the wing bushings help you to correctly install the universal joint. Figure 3.2. RPL35 and RPL35SD series drivelines are the same as RPL20, RPL25 and RPL25SD series drivelines except they are larger and have coupling flanges instead of yokes. Figure 3.3.

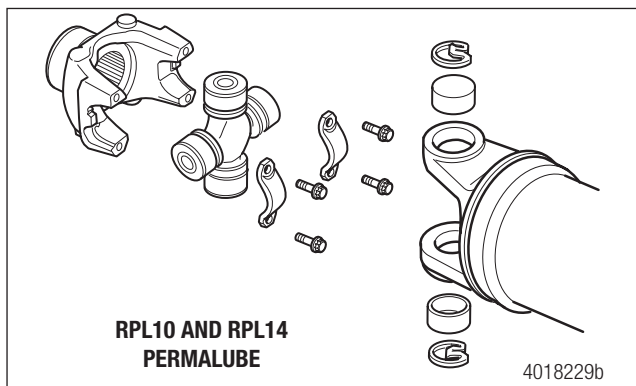

Figure 3.1

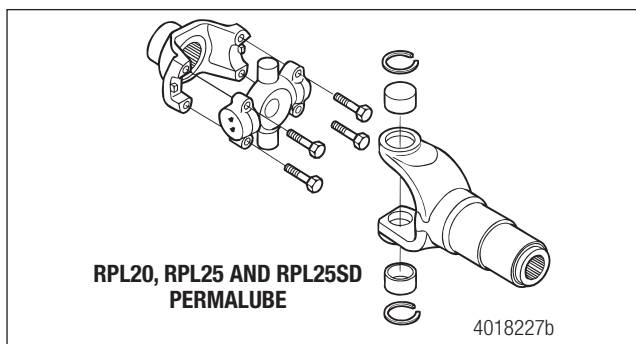

Figure 3.2

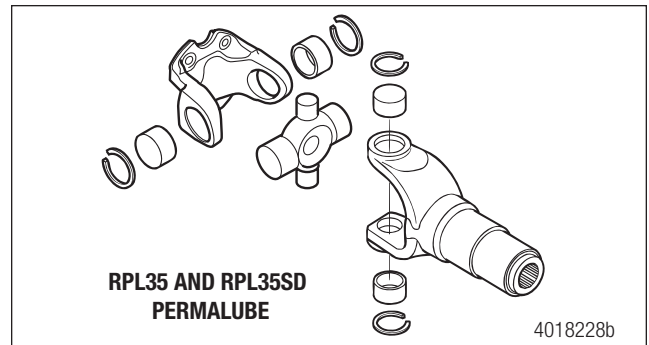

Figure 3.3

Wing-Style Permalube™

The Meritor Wing-Style Permalube driveline requires lubrication of the slip yoke splines only. Figure 3.4.

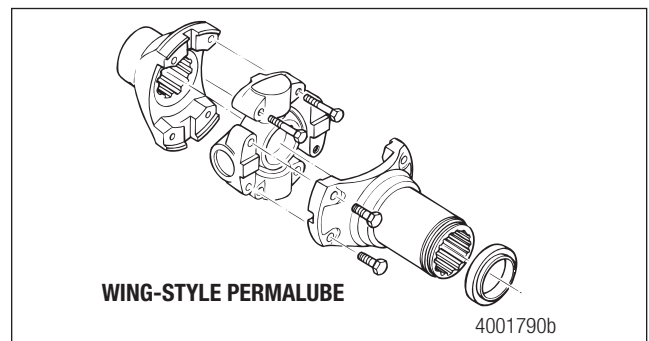

Figure 3.4

Full-Round, Easy Service™, Wing-Style and 155R Series (Greaseable)

Full-Round, Easy Service, Wing-Style and 155R greaseable drivelines require periodic lubrication of the universal joints and slip yoke splines. Figure 3.5, Figure 3.6, Figure 3.7 and Figure 3.8.

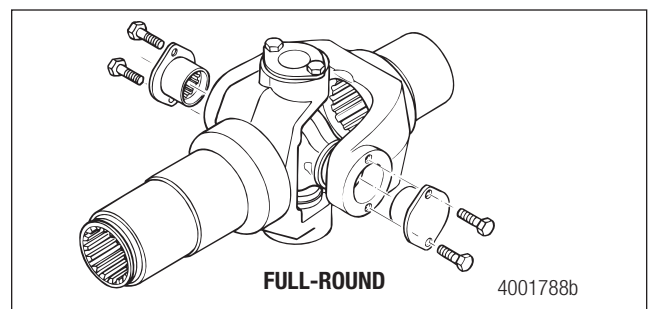

Figure 3.5

3 Introduction

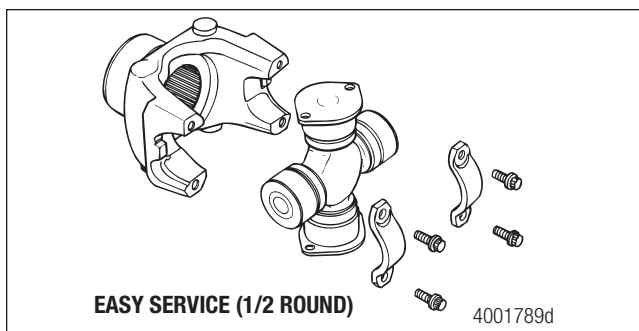

Figure 3.6

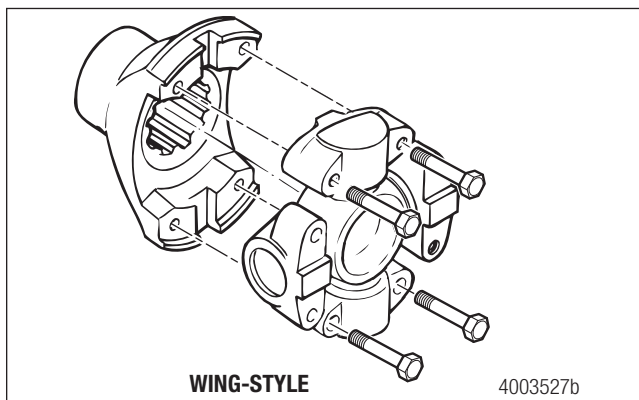

Figure 3.7

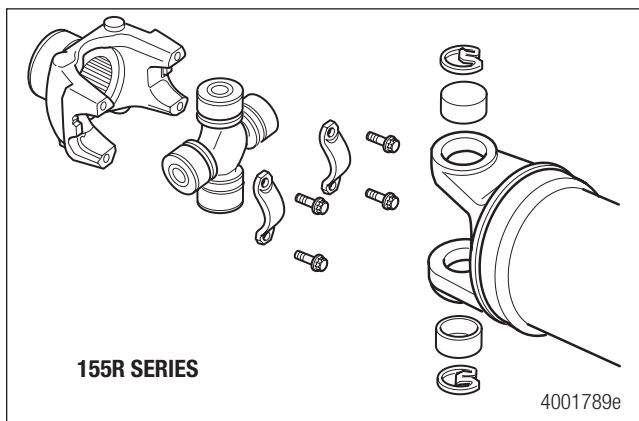

Figure 3.8

Inspection

Hazard Alert Messages

Read and observe all hazard alert messages in this publication.

⚠ DANGER

Park the vehicle on a level surface. Block the wheels to prevent the vehicle from moving. Support the vehicle with safety stands. NEVER work under a vehicle supported only by jacks. Jacks can slip and fall over. Failure to use safety stands can result in death or serious personal injury and damage to components.

⚠ DANGER

Check end yoke retaining nuts and bolts for looseness. Tighten loose fasteners to specification. Check the input and output shaft splines for wear and damage. Replace worn or damaged splines. Check for loose, missing or damaged driveline fasteners and parts. Tighten loose fasteners, and replace damaged and missing parts. Loose, damaged or missing parts can cause the driveline to separate from the vehicle. Serious personal injury and damage to components can result.

⚠ DANGER

Only service a driveline when the engine is OFF. A rotating driveline can cause serious personal injury and damage to components.

⚠ WARNING

To prevent eye injury, always wear eye protection when performing vehicle maintenance or service.

Driveline

1. Park the vehicle on a level surface. Block the wheels to keep the vehicle from moving. Raise the vehicle so that the area you will service is off the ground.
2. Inspect the driveline at regular intervals. Loose end yokes, excessive radial movement, slip spline radial movement, bent driveline tubing or missing plugs in the slip yoke can damage universal joints and bearings.
3. Check the output and input end yokes on both the transmission and axle for axial looseness. Refer to the axle or transmission manufacturer's service instructions.

If the output and input end yokes or flanges are

loose: Disconnect the driveline. Tighten the retaining nut to the correct specification. Refer to the axle or transmission manufacturer's service instructions.

4. Inspect for worn universal joints. Apply vertical force of about 50 pounds (22.7 kg) to the driveline near the universal joints.

If movement is greater than 0.006-inch (0.152 mm):

Replace the universal joint.

5. Inspect the slip section to ensure the welch plug and dust seal (under the shroud) are in the correct position.
6. Inspect the driveline for damaged or bent tubing. Carefully remove contaminants, such as mud and road debris.

End Yokes or Flanges

Perform the following procedures before you lubricate universal joints or slip yokes. If you lubricate these components before you inspect them, lubricant can conceal wear, damage and looseness.

1. Inspect all input and output end yokes or flanges for gaps between mating surfaces.

If gaps are present: Refer to the transmission, axle or transfer case manufacturer's service instructions.

2. Use the following procedure to check all input and output end yokes or flanges for looseness.
 - a. Hold the end yoke or flange with both hands.
 - b. Move the end yoke UP-AND-DOWN and SIDE-TO-SIDE. There shouldn't be any movement where the yoke or flange connects to the input and output shafts. Figure 4.1 and Figure 4.2.

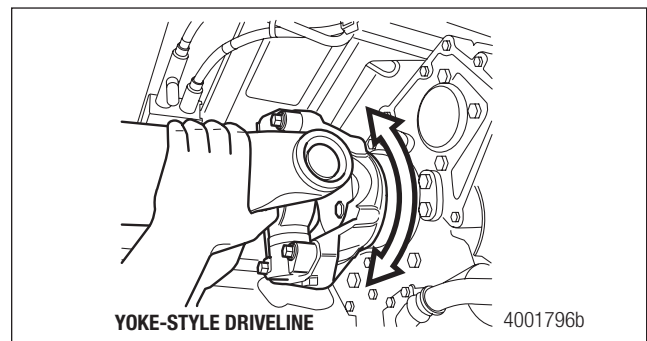

Figure 4.1

4 Inspection

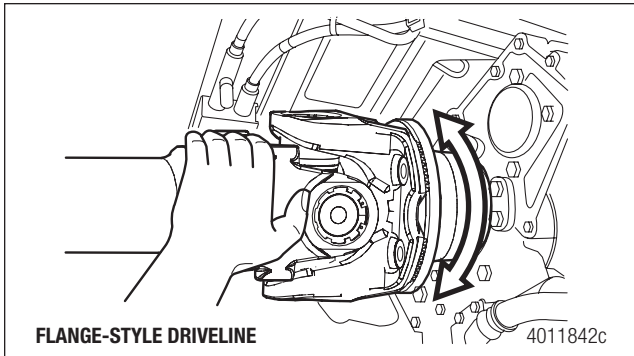

Figure 4.2

If the input and output end yokes or flanges are loose:

Disconnect the driveline. Tighten the retaining nut or bolt to the correct specification. Refer to the axle or transmission manufacturer for correct inspection and replacement procedures.

If the input and output end yokes or flanges are not loose, check that the transmission output shaft and axle input shaft splines aren't loose at the end yoke or flange:

Hold the yoke or flange with one hand and rotate it LEFT-TO-RIGHT while you check end play for radial looseness. Figure 4.1 and Figure 4.2.

If you find excessive radial looseness: Replace the end yoke or flange, or input or output shafts, as necessary.

3. Inspect for worn, damaged, missing and loose parts. Replace as required. Refer to the appropriate sections in this manual for these procedures.

⚠ DANGER

Use a fine-tooth file or an emery cloth to remove raised metal or fretting from yoke or flange cross hole surfaces. Take care not to remove an excessive amount of metal. These conditions can damage the cross and bearing and cause the driveline to separate from the vehicle. Serious personal injury and damage to components can result.

4. Inspect all end yoke or flange cross hole surfaces and bolt hole threads for damage. Remove raised metal or fretting with a fine-tooth file or emery cloth. Bolt holes must be clean and dry for assembly. Figure 4.3.

If bolt hole threads are damaged: Replace the yoke or flange.

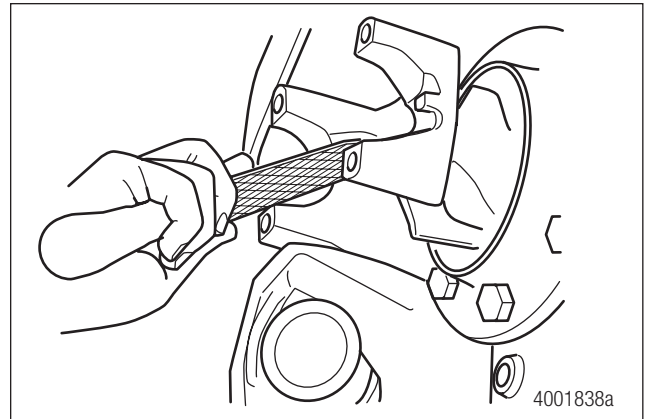

Figure 4.3

Universal Joints

⚠ DANGER

Excessive looseness across the ends of the universal joint bearing cup assemblies can cause imbalance or vibration in the driveline assembly. Imbalance or vibration can cause component wear, which can result in separation of the driveline from the vehicle. Serious personal injury and damage to components can result.

Use the following procedure to check for looseness across the ends of the universal joint bearing cup assemblies and trunnions.

1. Hold the INBOARD yoke or flange on the driveline with both hands.
2. Try to move the yoke or flange UP-AND-DOWN and SIDE-TO-SIDE by applying at least 50 pounds (22.7 kg) of force to the driveline near the universal joints. Figure 4.4 and Figure 4.5.

If movement is greater than 0.006-inch (0.152 mm):

Replace the universal joint.

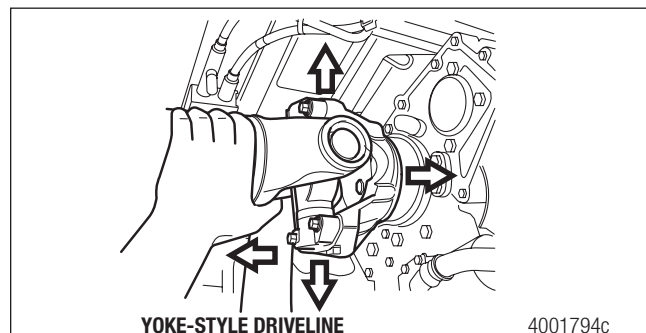

Figure 4.4

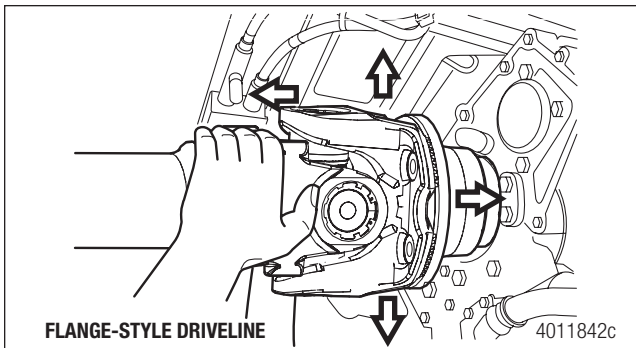

Figure 4.5

Greaseable Universal Joints

1. Check that all grease fittings are installed. Replace missing or damaged grease fittings with the correct type and size as specified in [PB-9895 Meritor Aftermarket Driveline Components](#). Tighten them to 6 lb-ft (8 Nm). Figure 4.6.
2. Check for loose grease fittings. Tighten them to 6 lb-ft (8 Nm).

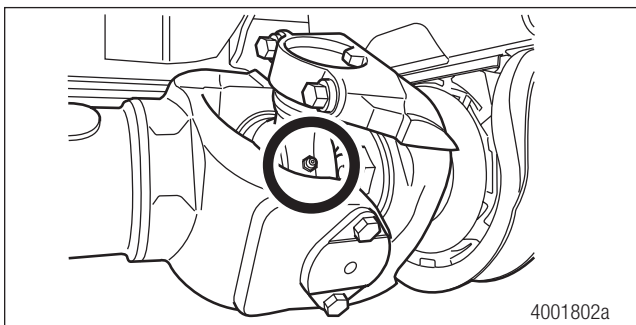

Figure 4.6

Center Bearings

1. Inspect all center bearing and end yoke or flange midship nuts for gaps or looseness between the mating surfaces. Figure 4.7 and Figure 4.8.

If you can see gaps between the mating surfaces:

Disconnect the driveline. Tighten the coupling yoke or flange retaining nut to 450-600 lb-ft (612-816 Nm).

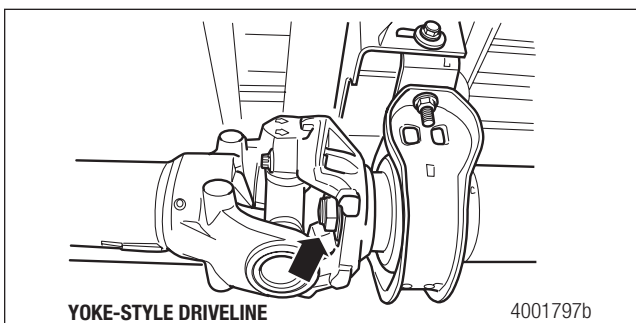

Figure 4.7

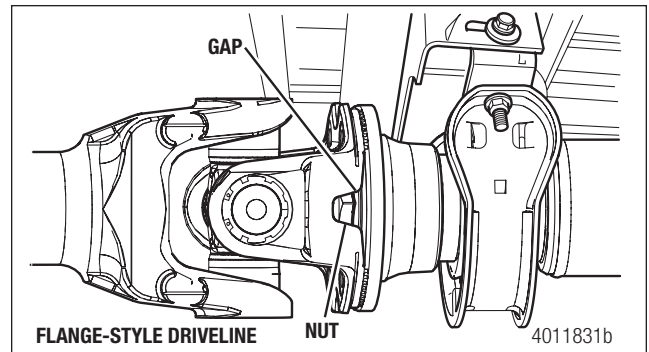

Figure 4.8

2. Inspect the center bearing bracket bolts for looseness. Figure 4.9 and Figure 4.10.

If the bolts are loose: Verify that the bracket is aligned correctly before you tighten the bolts. Tighten the center bearing bracket bolts. Refer to the vehicle manufacturer's procedures for the correct torque specification.

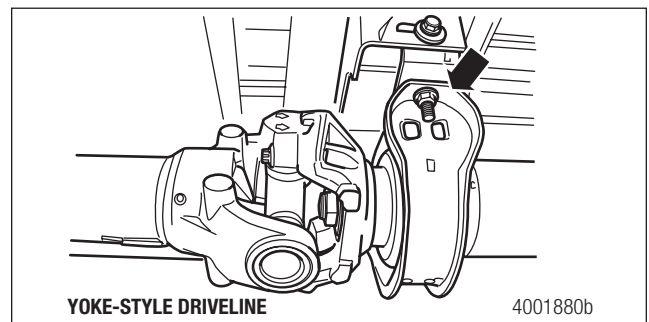

Figure 4.9

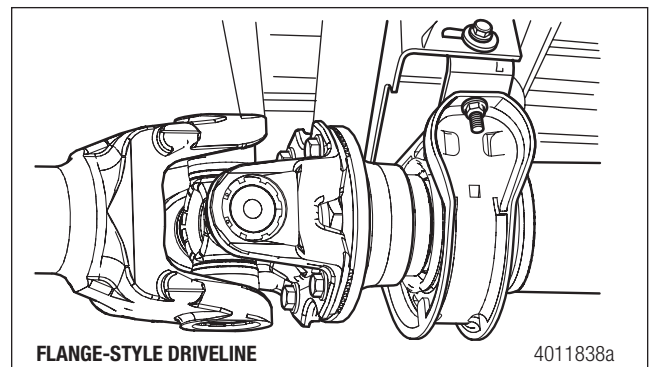

Figure 4.10

3. Inspect the center bearing rubber cushion for damage. If equipped, check that the deflectors are not rubbing against the rubber cushion. Verify that the rubber cushion is correctly seated in the metal bracket.

If any of these conditions are evident: Replace the center bearing assembly.

4 Inspection

Self-Aligning Center Bearings

A self-aligning center bearing accepts \pm five degrees of angular misalignment. This helps to ensure that the hanger bearing is correctly aligned to the driveline under all operating conditions.

Use the same service procedures for a self-aligning center bearing as for a standard center bearing. You can identify a self-aligning center bearing by the bright gold color of the integral deflector.

Deflectors are integral to a self-aligning center bearing, so separate deflectors are not required.

Most vehicles are equipped with self-aligning center bearings. Figure 4.11.

If you replace a self-aligning center bearing: You must install a new self-aligning center bearing.

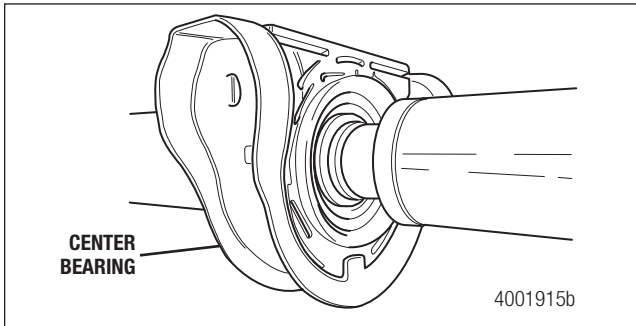

Figure 4.11

NOTE: Ensure all universal joints are secured in place prior to tightening the center bearing brackets.

Visual Inspection: Check the bearing placement in the rubber cushion. Figure 4.12.

Correction: Loosen the metal bracket and push the rubber cushion into place over the exposed bearing. Figure 4.12.

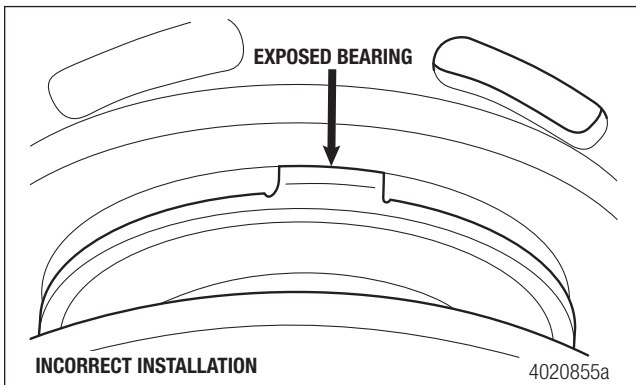

Figure 4.12

Visual Inspection: Check that the rubber cushion is straight with the bracket line, not bowed. Figure 4.13.

Correction: Loosen the metal bracket and adjust it between the slots to center the cushion so it is straight with the bracket line. Figure 4.13.

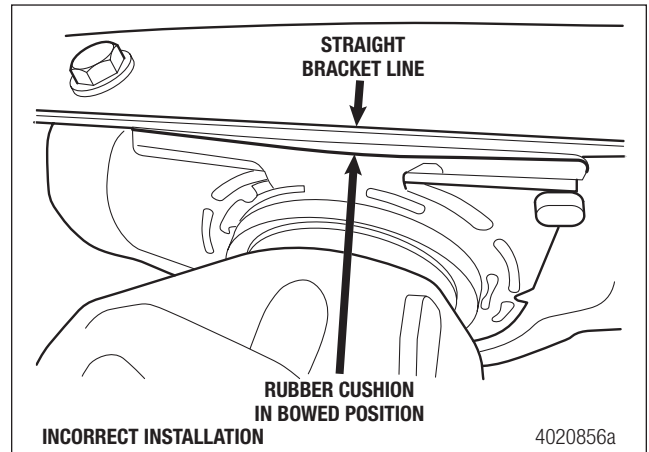

Figure 4.13

Slip Yoke

Check the dust seal to make sure it is in place on the slip yoke. Inspect for excessive wear on the rubber lip of the seal. If there is excessive movement and vibration of the slip yoke assembly, refer to Section 14 for the troubleshooting procedures.

Permalube™ Drivelines

Inspection and Maintenance

Table A: RPL Series Permalube and Wing-Style Permalube Driveline Inspection Intervals and Procedures

Mileage Intervals	Procedures
At initial inspection, or no more than 2,000 miles (3,200 km)	Verify that all bolts are tightened as follows. <ul style="list-style-type: none"> • Universal joint-to-end yoke bolts to 115-135 lb-ft (155-183 Nm) • Flange-to-flange bolts to 133-163 lb-ft (180-220 Nm)
Every 25,000 miles (40,000 km)	If you observe any of the following conditions, remove and replace components as needed. <ol style="list-style-type: none"> 1. Inspect all universal joints for grease purging. <p>If a universal joint shows normal grease purging: Do not replace the universal joint. Refer to TP-9980.</p> 2. Check for excessive looseness across the ends of the universal joint bearing cup assemblies and trunnions. <ul style="list-style-type: none"> • Grip driveline near the INBOARD yoke with both hands. • Try to move the yoke VERTICALLY and HORIZONTALLY. Movement in the universal joint relative to the INBOARD or OUTBOARD yokes must not exceed 0.006-inch (0.152 mm). Figure 4.4 and Figure 4.5. 3. Inspect the slip yoke spline seal for grease leakage or seal damage. 4. Inspect for missing balance weights, damaged tubing, or a missing welch plug at the slip yoke.
Every 150,000 miles (240,000 km)	<p>In addition to the 25,000-mile (40,000 km) requirements: Use the following steps to inspect the slip splines for wear (backlash) and for radial looseness between the slip yoke and the tube shaft.</p> <ol style="list-style-type: none"> 1. Ensure that the vehicle is on a level surface with its wheels on the ground. For single driveline systems, check the slip yoke for movement with the driveline installed. For multiple driveline systems, remove the slip yoke assembly from the vehicle and check for movement. 2. Firmly mount a dial indicator with a magnetic base onto the slip yoke barrel next to the dust seal. Figure 4.14. You do not want the dial indicator to move when you check the slip yoke for looseness, or the measurement will not be correct. 3. Extend the dial indicator arm from the base, so that it contacts the neck of the spline plug within 3/4-inch (19.05 mm) from the dust seal. Figure 4.14. 4. With your hands near the center of the driveline, move the slip yoke UP-AND-DOWN. Check the dial indicator measurement. Movement between the spline plug and slip yoke must not exceed 0.017-inch (0.432 mm). Figure 4.15. <p>If movement exceeds 0.017-inch (0.432 mm): Components are worn or damaged. Replace as required.</p> 5. Use a dial indicator to examine the slip yoke spline for excessive radial movement. Radial movement between the slip yoke and the tube shaft must not exceed 0.017-inch (0.432 mm). <p>If the radial movement exceeds 0.017-inch (0.432 mm): Replace the slip yoke and the tube shaft.</p>

4 Inspection

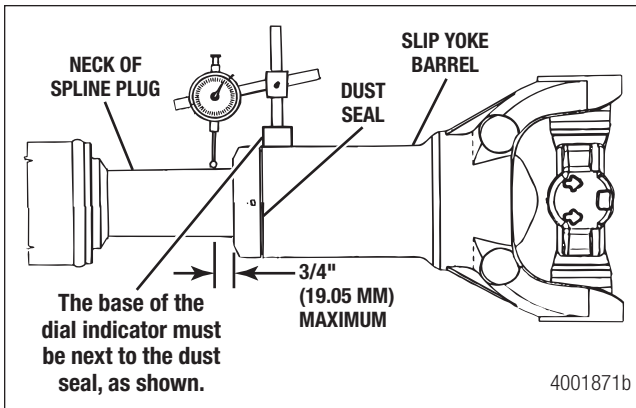

Figure 4.14

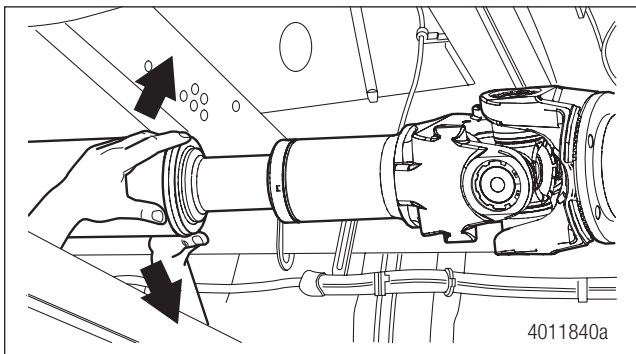

Figure 4.15

Check Universal Joint Capscrews

⚠ DANGER

Inspect RPL Series Permalube and Wing-Style Permalube drivelines for loose or missing capscrews and lock washers. Loose or missing fasteners can allow the driveline to separate from the vehicle. Serious personal injury and damage to components can result. If fasteners are loose or missing:

- RPL Series Permalube drivelines: Install new capscrews with Dri-Loc patches.
- Wing-Style Permalube drivelines: Install new capscrews with Dri-Loc patches and secure the capscrews with lock washers.

Meritor recommends that you inspect RPL Series Permalube bearing cup capscrews and wing-style capscrews and lock washers at initial inspection, or no more than 2,000 miles (3200 km).

On RPL Series Permalube Drivelines

1. Check that capscrews are installed on all universal joint positions. RPL Series Permalube capscrews and Wing-Style Permalube capscrews are not interchangeable.

If capscrews are missing: Check for damage to the universal joint and yoke. Replace damaged parts and missing capscrews.

If capscrews are loose: Remove and discard loose capscrews. Replace them with new capscrews.

2. Use a torque wrench to verify that capscrews are tightened as follows.

- Universal joint-to-end yoke capscrews to 115-135 lb-ft (155-183 Nm).
- Flange-to-flange capscrews to 133-163 lb-ft (180-220 Nm).

On Wing-Style Permalube Drivelines

1. Check that both capscrews and lock washers are installed on all universal joint positions. RPL Series Permalube capscrews and Wing-Style Permalube capscrews are not interchangeable.

If capscrews and lock washers are missing: Check for damage to the universal joint and yoke. Replace damaged parts, capscrews and lock washers. Refer to Section 8.

If capscrews are loose: Remove and discard loose capscrews. Replace them with new capscrews and lock washers.

2. Use a torque wrench to verify that capscrews are tightened to the correct specification. Refer to Section 13.

Check End Play

Check the universal joint for end play. Apply force in an UP-AND-DOWN and SIDE-TO-SIDE motion. Figure 4.16 and Figure 4.17. There should be less than 0.006-inch (0.152 mm) BACK-AND-FORTH motion of the universal joint. Figure 4.18 and Figure 4.19.

If movement is greater than 0.006-inch (0.152 mm): Replace the universal joint.

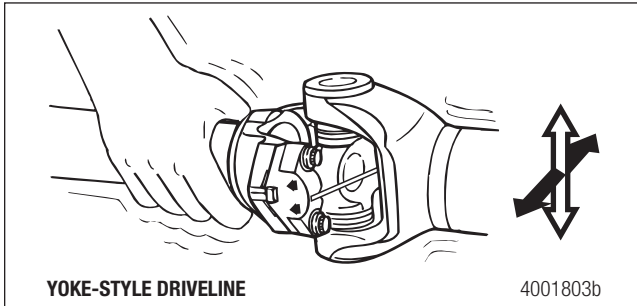

Figure 4.16

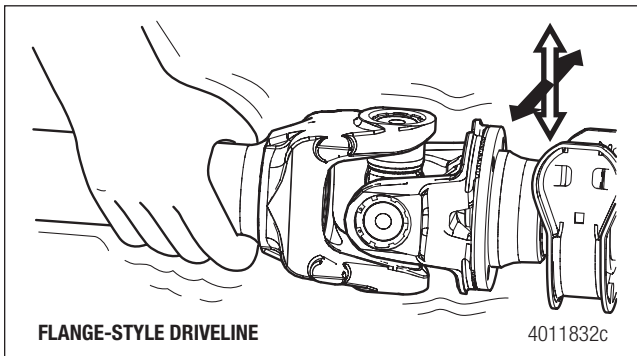

Figure 4.17

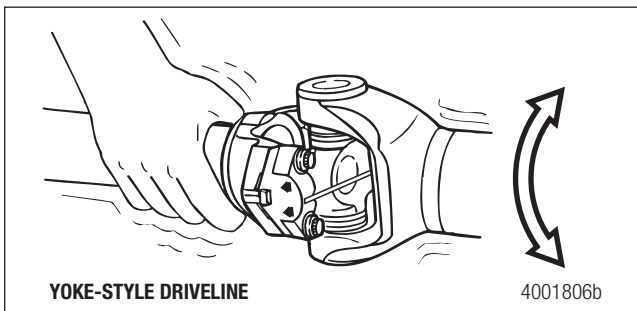

Figure 4.18

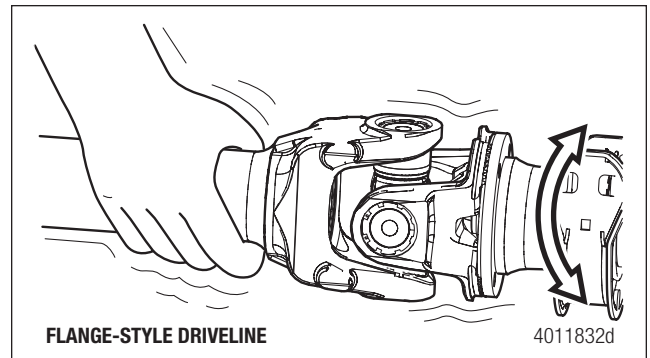

Figure 4.19

5 RPL Series Permalube

RPL Series Permalube

Hazard Alert Messages

Read and observe all hazard alert messages in this publication.

RPL10 and RPL14 Series Permalube Procedures

The following procedures are for RPL10 and RPL14 series Permalube drivelines. For RPL20, RPL25, RPL25SD, RPL35 and RPL35SD series Permalube drivelines, refer to the procedures later in this section.

⚠ DANGER

Park the vehicle on a level surface. Block the wheels to prevent the vehicle from moving. Support the vehicle with safety stands. NEVER work under a vehicle supported only by jacks. Jacks can slip and fall over. Failure to use safety stands can result in death or serious personal injury and damage to components.

⚠ DANGER

Only service a driveline when the engine is OFF. A rotating driveline can result in death or serious personal injury and damage to components.

⚠ WARNING

To prevent eye injury, always wear eye protection when performing vehicle maintenance or service.

⚠ WARNING

Use a brass or synthetic mallet for assembly and disassembly procedures. NEVER hit steel parts with a steel hammer. Pieces of a part can break off. Serious personal injury and damage to components can result.

⚠ WARNING

Only install the correct grade new bearing retainer bolts and stamped strap bolts. Do not reuse these parts. If the bearing retainer straps are damaged, install new retainers. Damaged and reused parts can affect driveline operation, which can cause the driveline to separate from the vehicle. Serious personal injury and damage to components can result.

⚠ WARNING

A driveline assembly can weigh more than 100 pounds (46 kilograms). Always use lifting devices and the correct procedures when handling drivelines to prevent serious personal injury and damage to components.

Removal

Driveline

1. Park the vehicle on a level surface. Release the parking brake to allow the driveline to rotate freely. Block the wheels to keep the vehicle from moving. Raise the vehicle so that the area to be serviced is off the ground. Support the vehicle with safety stands.
2. Loosen and remove the capscrews and bearing straps from the weld yoke end of the driveline. Support the weld yoke end and separate it from the end yoke.
3. Loosen and remove the capscrews and bearing straps from the slip yoke end of the driveline. Support the slip yoke end and separate it from the vehicle.

Universal Joint

Snap Ring Removal

NOTE: Refer to the Service Notes page on the front inside cover of this manual for information on how to obtain tools.

1. Use snap ring pliers to remove the snap rings. Figure 5.1.

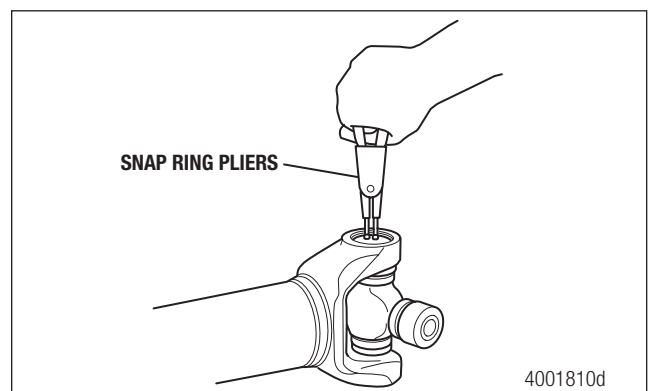

Figure 5.1

2. If necessary, use a brass drift and lightly tap the center of the bushing to assist in snap ring removal. Figure 5.2.

5 RPL Series Permalube

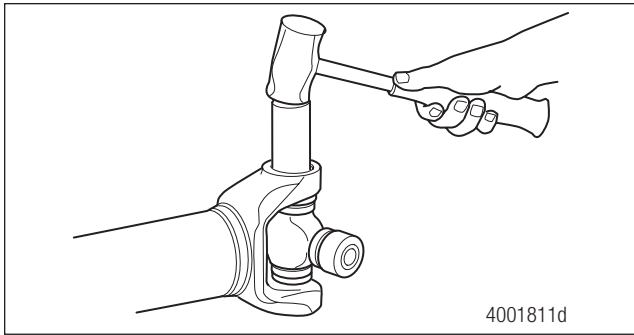

Figure 5.2

3. Repeat the previous steps on the other side of the yoke.

Round Bushing Removal Using Press, Bridge and Bearing Cup Receiver

NOTE: Use only the appropriate tools to remove the round bushings. Do not use the SPX Kent-Moore yoke bearing cup installation tool (number J-44516) to remove the round bushings. Damage to the tool can result.

Use the following procedure to remove and install round bushings.

⚠ DANGER

Observe all hazard alerts provided by the press manufacturer. Failure to do so can result in death or serious personal injury and damage to components.

1. Place the universal joint in a suitable press bridge and bearing cup bushing receiver. Figure 5.3.

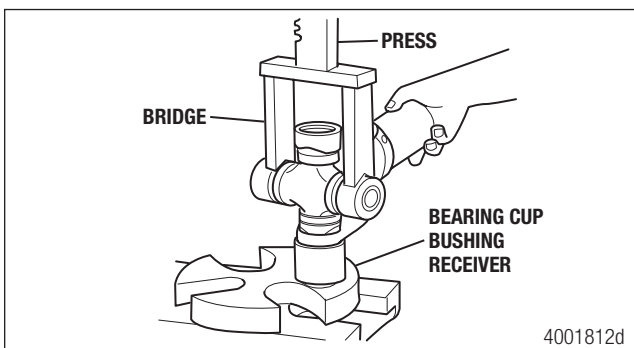

Figure 5.3

2. Press DOWN until the first round bushing loosens. Figure 5.3. Remove the round bushing. Figure 5.4.

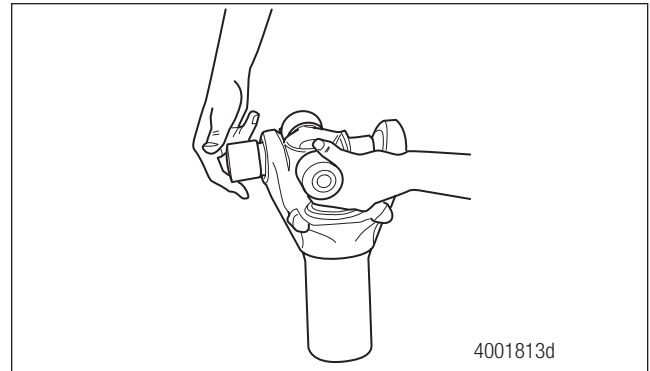

Figure 5.4

3. Rotate the shaft 180 degrees. Repeat the procedure for the opposite side of the universal joint. Figure 5.5.

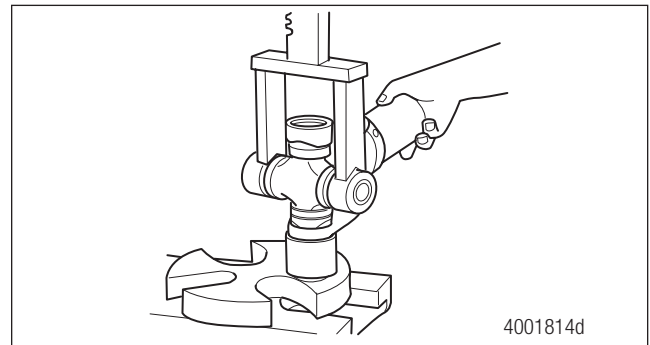

Figure 5.5

4. Remove the universal joint from the yoke.

Disassembly

Standard Slip Configuration

1. Use a brass or copper hammer and a drift to tap the shroud off the slip seal.
2. Use a screwdriver to pry the seal out of the groove in the slip yoke.
3. Mark the slip yoke and slip shaft sections to ensure that you reassemble them into their original positions. Figure 5.6.

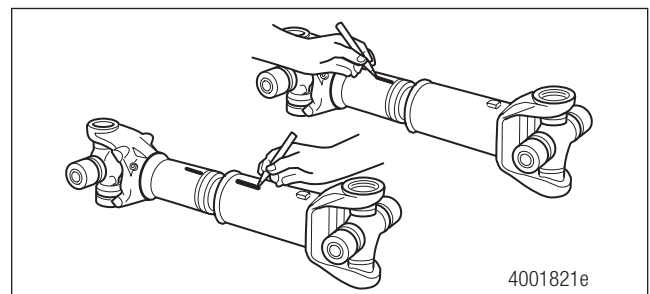

Figure 5.6

5 RPL Series Permalube

4. Pull the slip yoke and slip shaft sections apart. Figure 5.7.

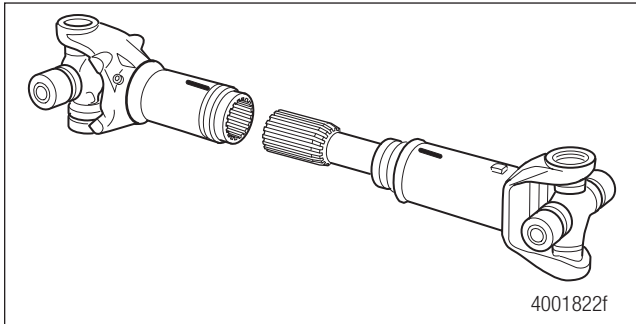

Figure 5.7

5. Remove the seal and shroud from the slip shaft. Figure 5.8 and Figure 5.9.

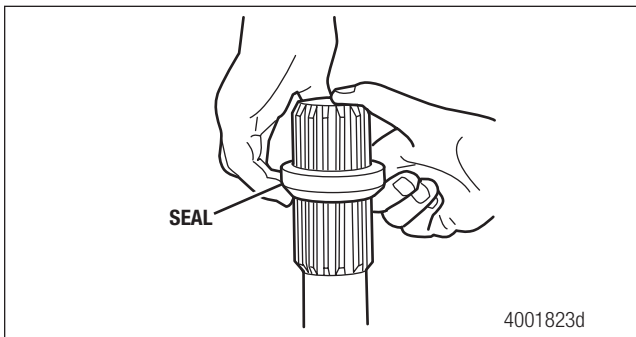

Figure 5.8

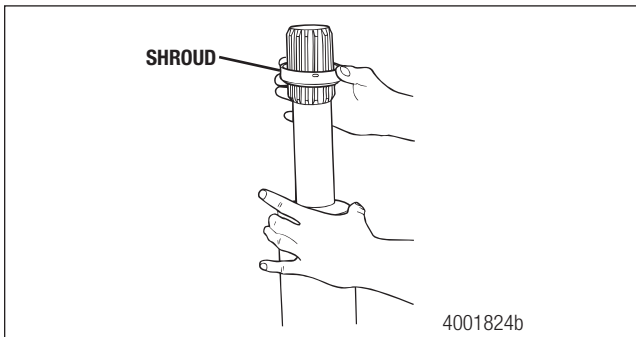

Figure 5.9

Assembly

Standard Slip Configuration

1. Remove the grease fittings from the slip yoke before assembling the slip yoke and spline shaft sections.
2. Use the grease packet supplied with the slip yoke to apply the entire amount of grease into the slip yoke. Figure 5.10.

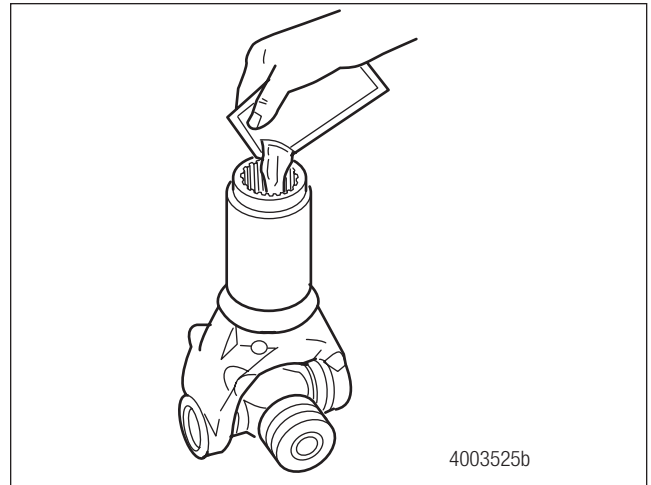

Figure 5.10

3. Use a brush to distribute lubricant on the splines. Figure 5.11.

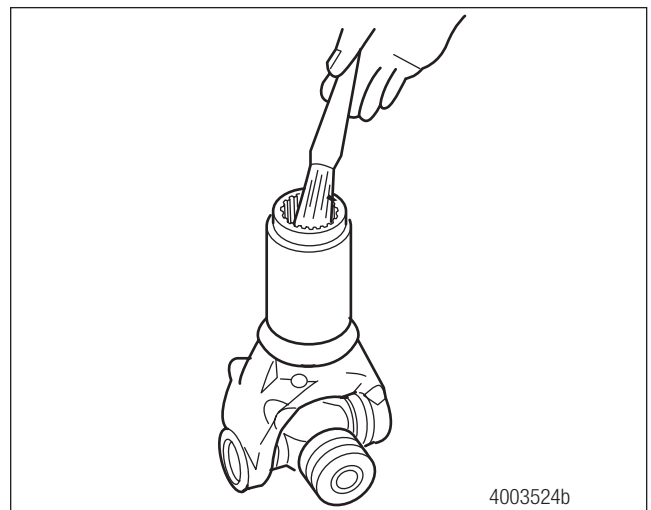

Figure 5.11

4. Install the new shroud onto the spline shaft. Figure 5.12.

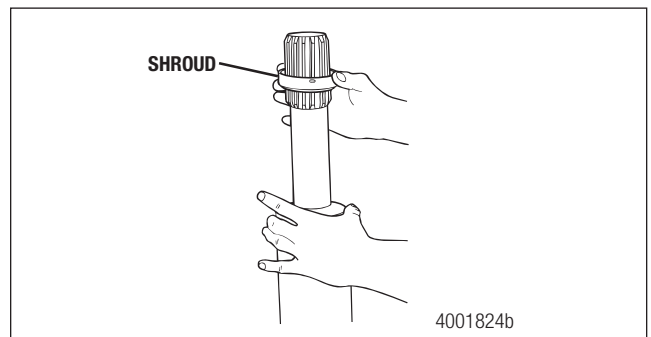

Figure 5.12

5 RPL Series Permalube

5. Install the new seal onto the spline shaft neck. Ensure that the small diameter side fits onto the splines first. Figure 5.13.

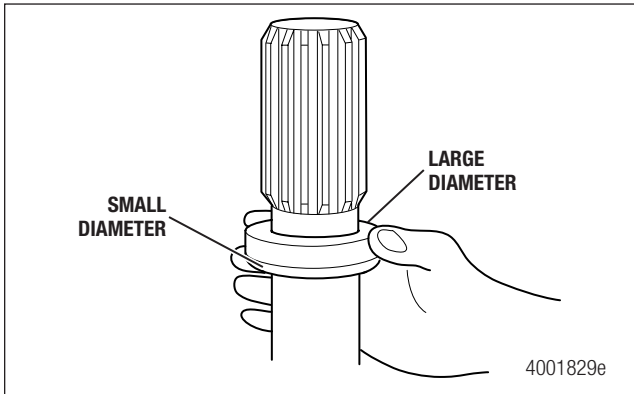

Figure 5.13

6. Align the slip yoke and spline shaft sections with the phasing marks you made on these sections during disassembly. Figure 5.14.

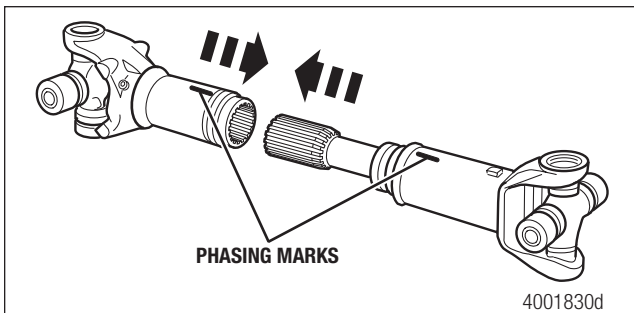

Figure 5.14

7. Install the spline shaft into the slip yoke until the splines fully engage. Figure 5.14.
8. Snap the seal into the groove. Figure 5.15.

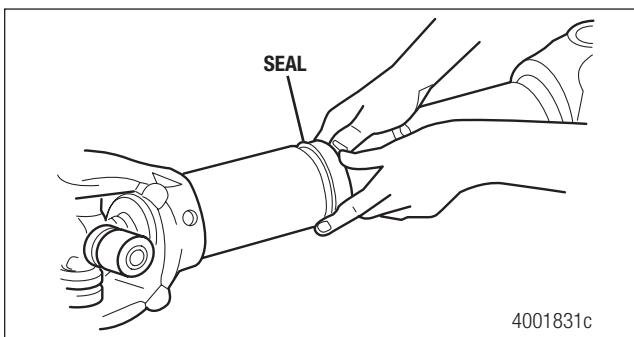

Figure 5.15

9. Snap the shroud over the seal. Figure 5.16.

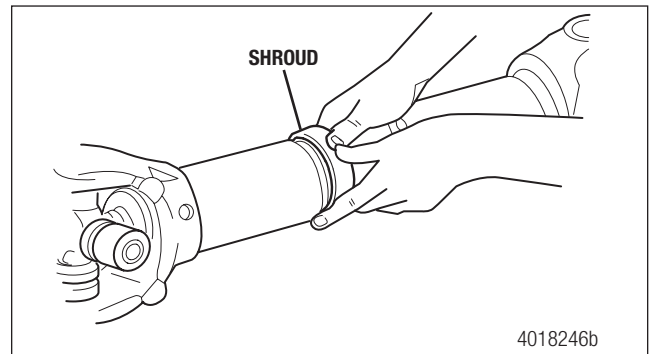

Figure 5.16

10. Push together the driveline sections. Figure 5.17.

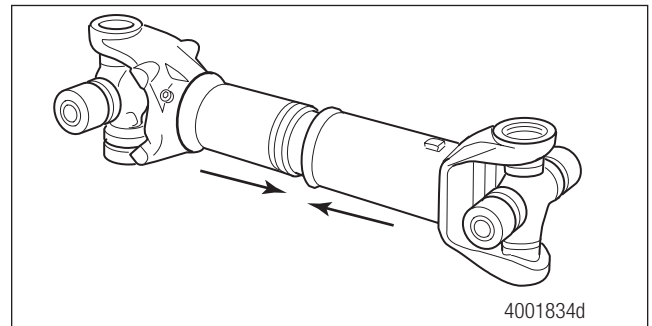

Figure 5.17

11. Reinstall the grease fittings. If damaged, replace the grease fittings with the correct type and size as specified in [PB-9895, Meritor Aftermarket Driveline Components](#).

Installation

Universal Joint

⚠ CAUTION

Do not use grease or anti-seize compound in the yoke ear bores. Damage to components can result.

1. Clean dirt and contamination from the slip yoke and weld yoke ear bores.

NOTE: The deflector is preassembled onto the bushing.

2. Position the first bushing onto the trunnion by threading the cross trunnion through the yoke bore. Figure 5.18.

5 RPL Series Permalube

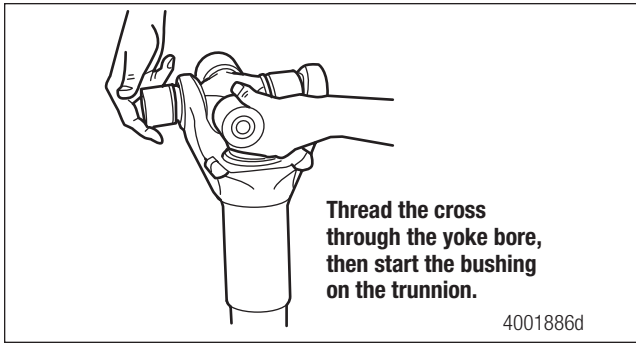

Figure 5.18

⚠ DANGER

Observe all warnings and cautions provided by the press manufacturer. Failure to do so can result in death or serious personal injury and damage to components.

⚠ CAUTION

Use an arbor press or universal joint press to install the round bushing into the yoke. Do not use a hammer, which can loosen and damage components.

- Use an appropriate press to install the first bushing slightly past the snap ring groove. Figure 5.19.

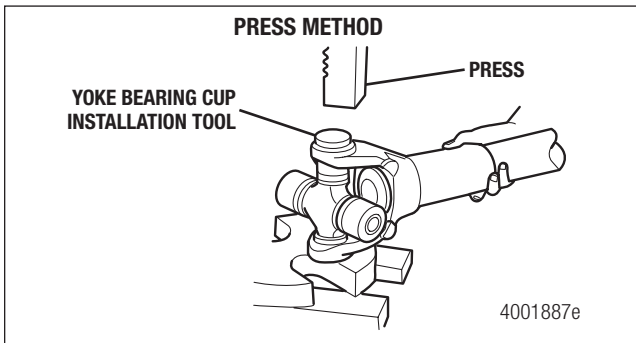

Figure 5.19

⚠ CAUTION

The snap ring must be fully seated into the snap ring groove to avoid damage to the driveline.

- Use snap ring pliers to install the snap ring into the snap ring groove. Figure 5.20. Fully seat the snap ring.

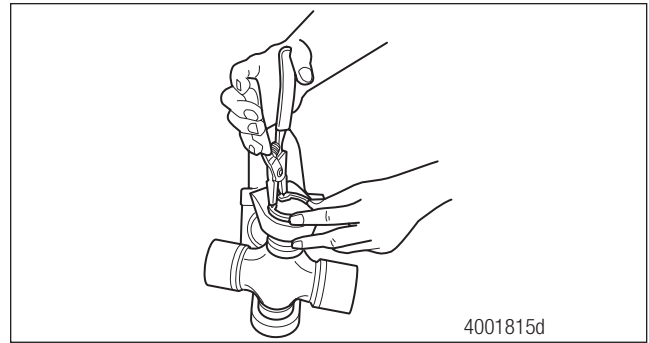

Figure 5.20

- Position the second bushing onto the trunnion by threading the cross through the yoke bore as shown. Figure 5.21.

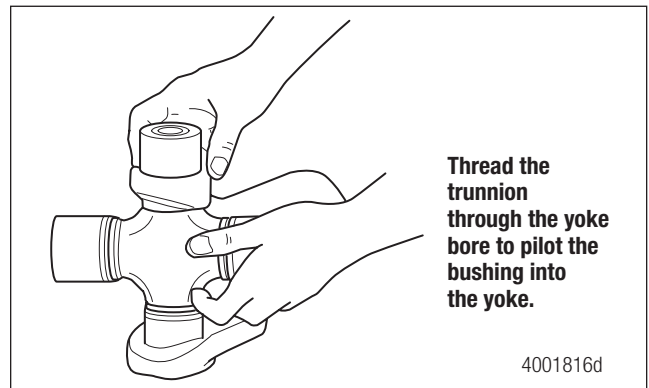

Figure 5.21

- Use an appropriate press, yoke bearing cup installation tool or universal joint press to install the second bushing slightly past the snap ring groove. Check that the bushing is aligned with the universal joint. Figure 5.19.

⚠ CAUTION

The snap ring must be fully seated into the snap ring groove to avoid damage to the driveline.

- Use snap ring pliers to install the second snap ring into the snap ring groove. Figure 5.22.

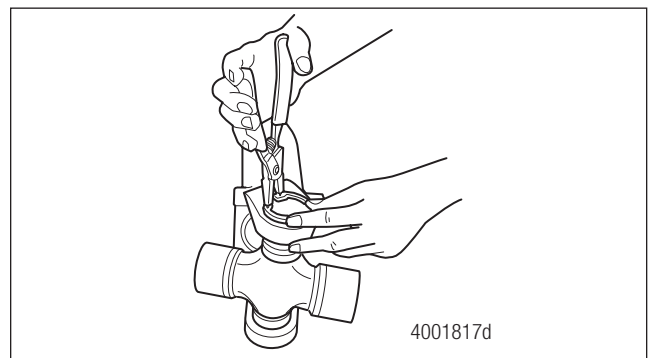

Figure 5.22

- Strike the yoke ear with a brass or copper hammer to ensure that the universal joint moves freely. Figure 5.23.

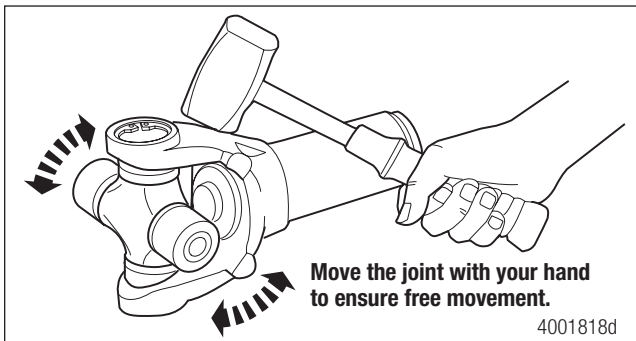

Figure 5.23

Driveline

- Wipe off the yoke saddle.

⚠ DANGER

Any time a universal joint is disconnected, new capscrews must be used during reassembly. Reusing old capscrews can cause the drive shaft to loosen or separate from the vehicle. Death or severe personal injury and damage to components can occur.

- Support the driveline. Install the bearing straps and new capscrews onto the slip yoke end of the driveline.

NOTE: Capscrews have a “lock patch” and can be hand-tightened only two or three threads.

- Hand-tighten the capscrews through the bearing strap into the yoke.
- Use a torque wrench to alternately tighten the capscrews to Meritor’s driveline torque specification. Figure 5.24.

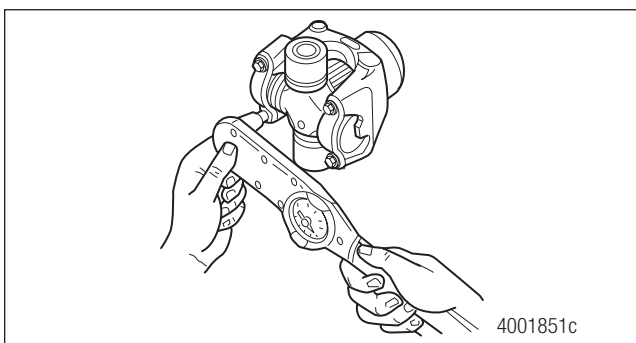

Figure 5.24

- Repeat Step 1 to Step 3 to attach the weld yoke end of the driveline to the vehicle.

RPL20, RPL25 and RPL25SD Series Permalube Procedures

The following procedures are for RPL20, RPL25 and RPL25SD series Permalube drivelines. For RPL10, RPL14, RPL35 and RPL35SD series Permalube drivelines, refer to those procedures at the beginning and end of this section.

⚠ DANGER

Park the vehicle on a level surface. Block the wheels to prevent the vehicle from moving. Support the vehicle with safety stands. NEVER work under a vehicle supported only by jacks. Jacks can slip and fall over. Failure to use safety stands can result in death or serious personal injury and damage to components.

⚠ DANGER

Only service a driveline when the engine is OFF. A rotating driveline can result in death or serious personal injury and damage to components.

⚠ WARNING

To prevent eye injury, always wear eye protection when performing vehicle maintenance or service.

⚠ WARNING

Use a brass or synthetic mallet for assembly and disassembly procedures. NEVER hit steel parts with a steel hammer. Pieces of a part can break off. Serious personal injury and damage to components can result.

⚠ WARNING

Only install the correct grade new bearing retainer bolts and stamped strap bolts. Do not reuse these parts. If the bearing retainer straps are damaged, install new retainers. Damaged and reused parts can affect driveline operation, which can cause the driveline to separate from the vehicle. Serious personal injury and damage to components can result.

⚠ WARNING

A driveline assembly can weigh more than 100 pounds (46 kilograms). Always use lifting devices and the correct procedures when you handle drivelines to prevent serious personal injury and damage to components.

5 RPL Series Permalube

Removal

Driveline

1. Park the vehicle on a level surface. Release the parking brake to allow the driveline to rotate freely. Block the wheels to keep the vehicle from moving. Raise the vehicle so that the area you will service is off the ground. Support the vehicle with safety stands.

⚠ CAUTION

Do not cut the weld strap. Damage to components can result.

2. Use a 12-point socket to loosen the four bolts (1/2 x 20-inch thread) located in the weld yoke end of the driveline. Figure 5.25.

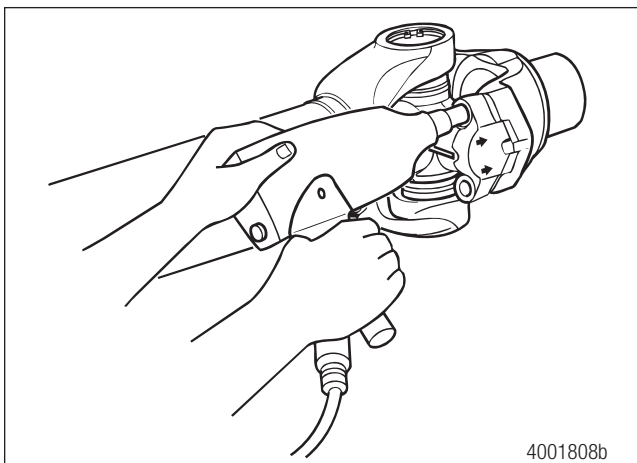

Figure 5.25

3. Remove the capscrews. Figure 5.26.

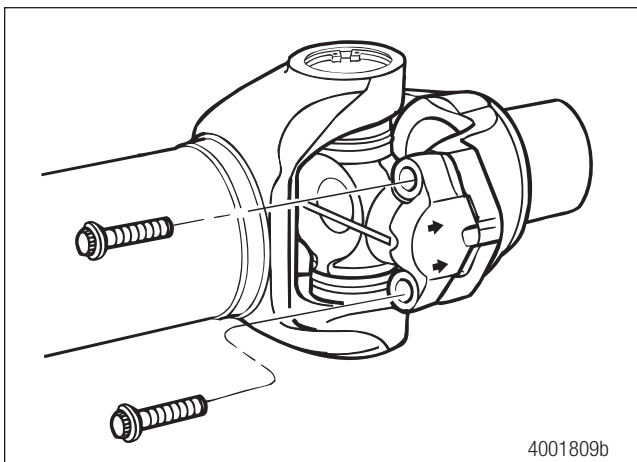

Figure 5.26

NOTE: Support the driveline when you remove it from the end yoke.

4. If necessary, use an appropriate tool to tap the wing bushing from the end yoke. Figure 5.27.
5. Repeat Step 2 through Step 4 to remove the opposite end of the driveline.

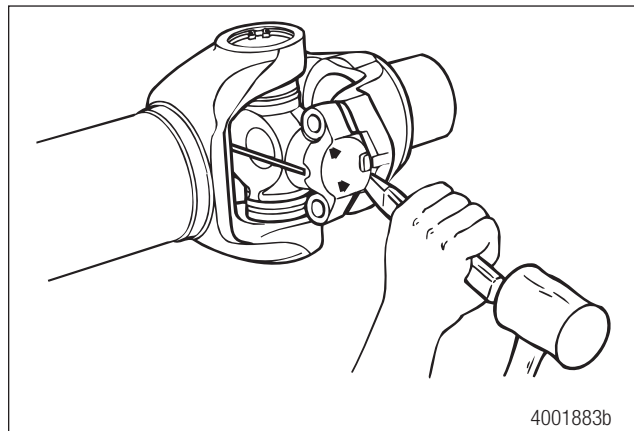

Figure 5.27

Universal Joint

Snap Ring Removal

NOTE: Refer to the Service Notes page on the front inside cover of this manual for information on how to obtain tools.

1. Use snap ring pliers to remove the snap rings. Figure 5.28.

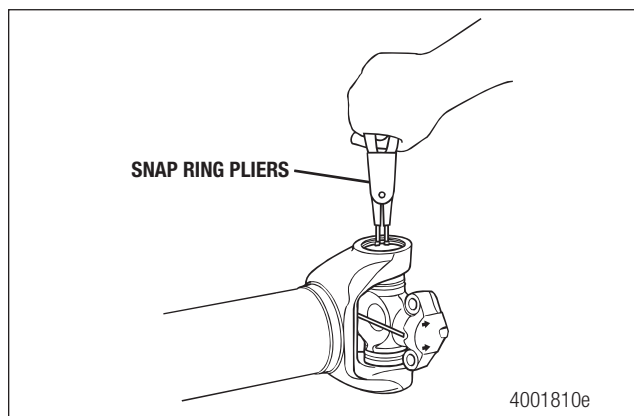

Figure 5.28

2. If necessary, use a brass drift and lightly tap the center of the bushing to assist in snap ring removal. Figure 5.29.

5 RPL Series Permalube

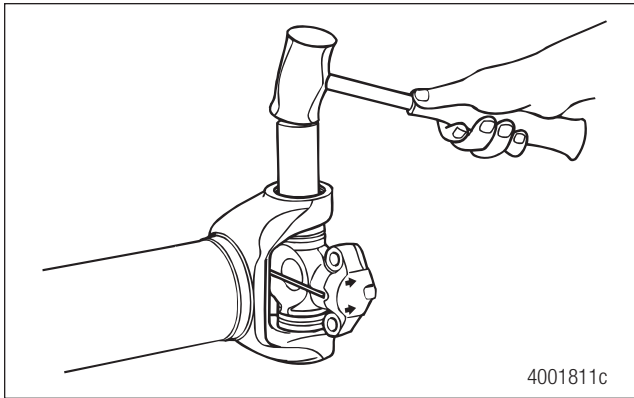

Figure 5.29

3. Repeat the previous steps on the other side of the yoke.

Round Bushing Removal

NOTE: Use only the specified tools to remove the round bushings. Do not use the SPX Kent-Moore yoke bearing cup installation tool (number J-44516) to remove the round bushings. Damage to the tool can result.

Use one of the following procedures to remove and install round bushings.

- Press, bridge tool and bearing cup bushing receiver
- Universal joint press
- Universal joint puller

DANGER

Observe all hazard alerts provided by the press manufacturer. Failure to do so can result in death or serious personal injury and damage to components.

Method Using a Press, Bridge Tool and Bearing Cup Bushing Receiver

1. Use a press, bridge tool and bearing cup bushing receiver. Figure 5.30. Refer to the Service Notes page on the front inside cover of this manual for information to obtain these tools.

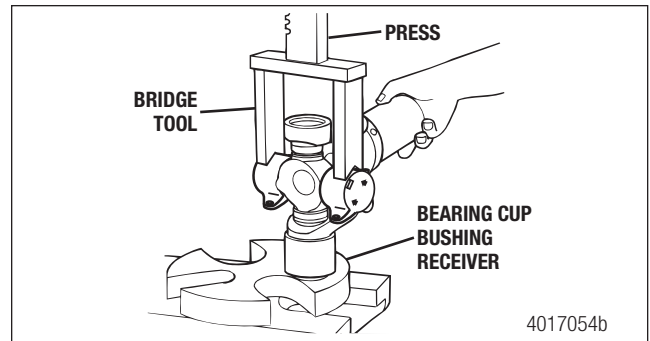

Figure 5.30

2. Press DOWN until the first round bushing loosens. Figure 5.30. Remove the round bushing. Figure 5.31.

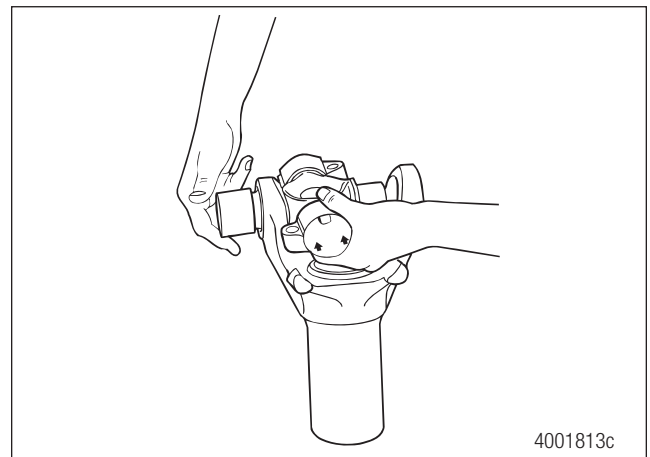

Figure 5.31

3. Rotate the shaft 180 degrees. Repeat the procedure for the opposite side of the universal joint. Figure 5.32.

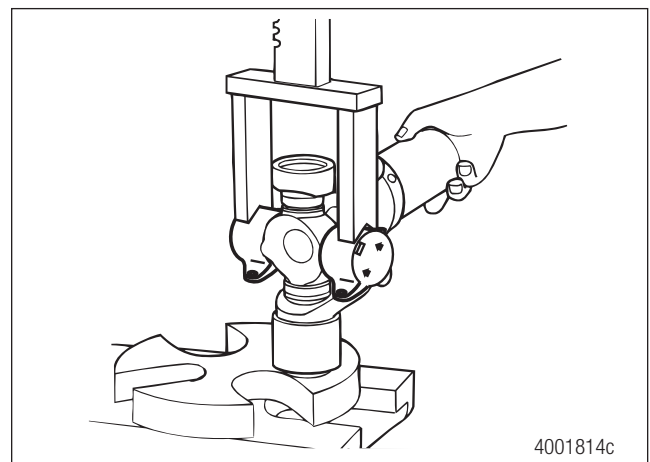

Figure 5.32

4. Remove the universal joint from the yoke.

5 RPL Series Permalube

Method Using a Universal Joint Press

1. Position a universal joint press (Tiger Tool number 10707). Figure 5.33. Refer to the Service Notes page on the front inside cover of this manual for information to obtain this tool.

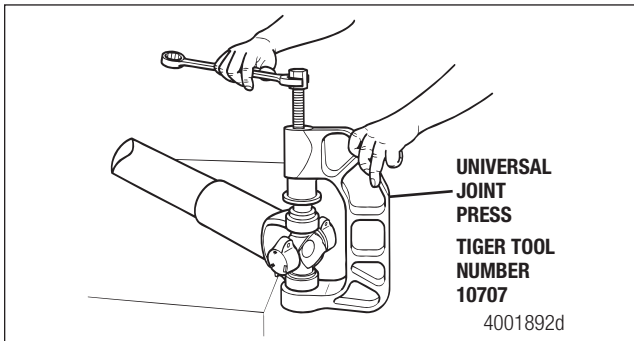

Figure 5.33

2. Turn the screw on the tool **CLOCKWISE** until the round bushing loosens.
3. Turn the screw on the tool **COUNTERCLOCKWISE** until you can remove the round bushing.
4. Turn over the universal joint. Repeat the procedure for the opposite side of the universal joint.
5. Remove the universal joint from the yoke.

Method Using a Universal Joint Puller

1. Position a universal joint puller (Tiger Tool number 10102). Refer to the Service Notes page on the front inside cover of this manual for information to obtain this tool. Figure 5.34.

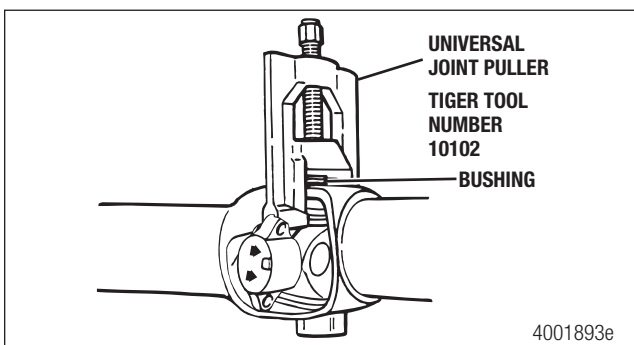

Figure 5.34

2. Turn the screw on the tool **CLOCKWISE** until the round bushing loosens.
3. Turn the screw on the tool **COUNTERCLOCKWISE** and remove the round bushing.
4. Turn over the universal joint. Repeat the procedure for the opposite side of the universal joint.

5. Remove the universal joint from the yoke.

Disassembly

Slip Yoke

1. Use a brass or copper hammer and a drift to tap the shroud off the slip seal. Figure 5.35.

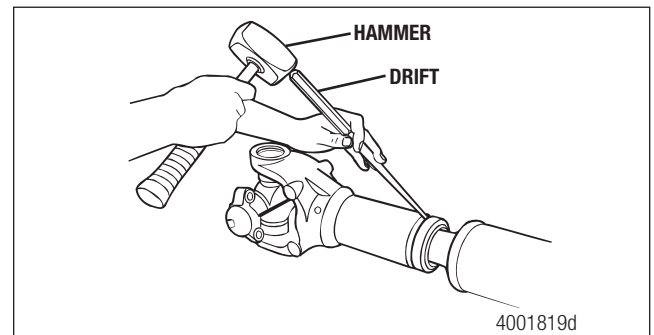

Figure 5.35

2. Use a screwdriver to pry the seal out of the groove in the slip yoke. Figure 5.36.

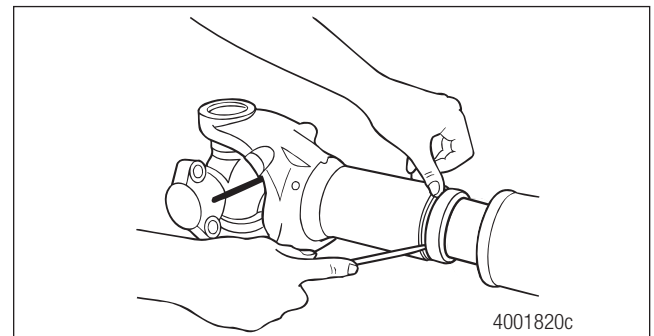

Figure 5.36

3. Mark the slip yoke and slip shaft sections to ensure that you reassemble them into their original positions. Figure 5.37.

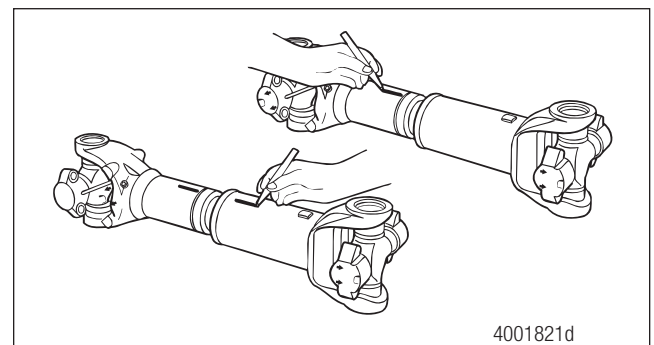

Figure 5.37

5 RPL Series Permalube

4. Pull the slip yoke and slip shaft sections apart. Figure 5.38.

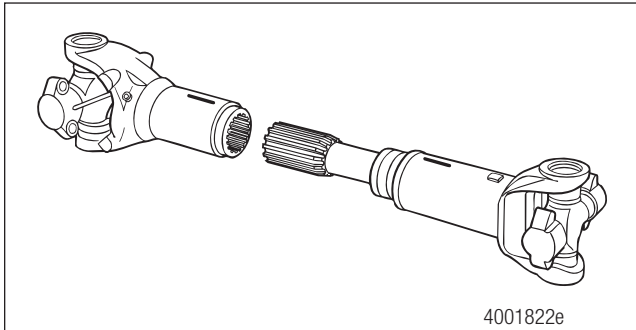

Figure 5.38

5. Remove the seal and shroud. Figure 5.39 and Figure 5.40.

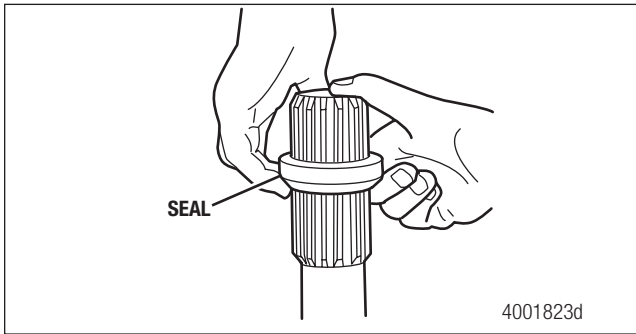

Figure 5.39

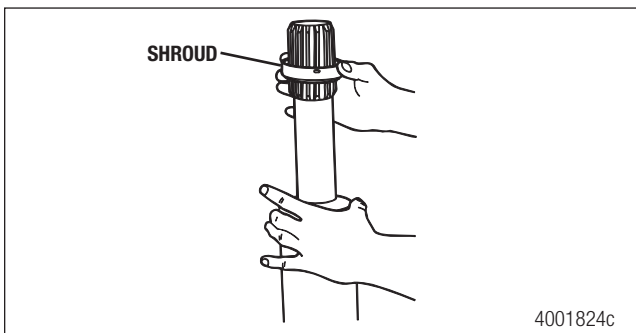

Figure 5.40

Assembly

Slip Yoke

1. Use the grease packet supplied with the slip yoke to apply the entire amount of grease into the slip yoke. Figure 5.41.

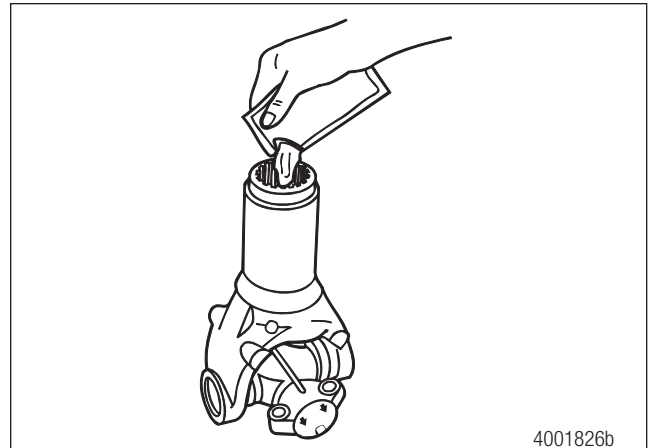

Figure 5.41

2. Use a brush to distribute lubricant on the splines. Figure 5.42.

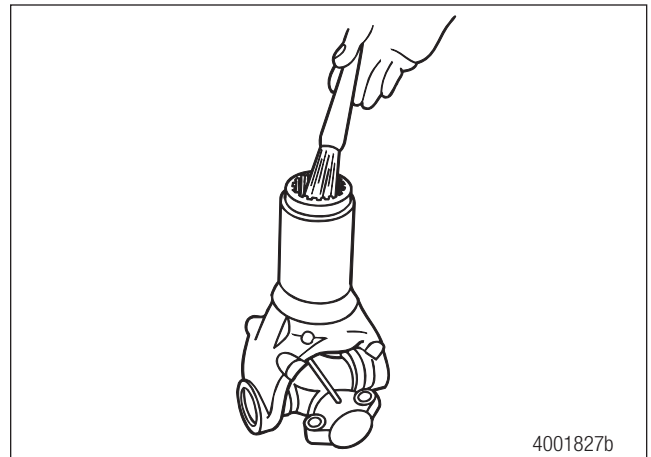

Figure 5.42

3. Install the new shroud. Figure 5.43.

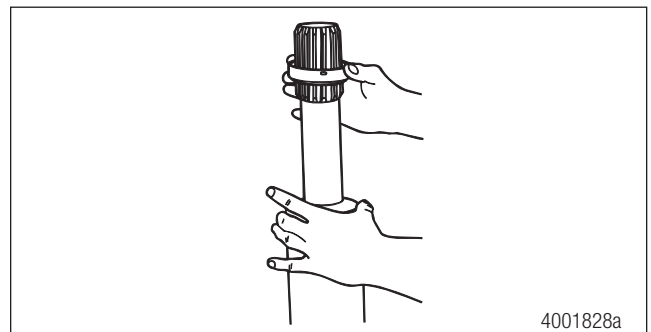

Figure 5.43

5 RPL Series Permalube

4. Install the new seal onto the spline shaft neck. Ensure that the small diameter side fits onto the splines first. Figure 5.44.

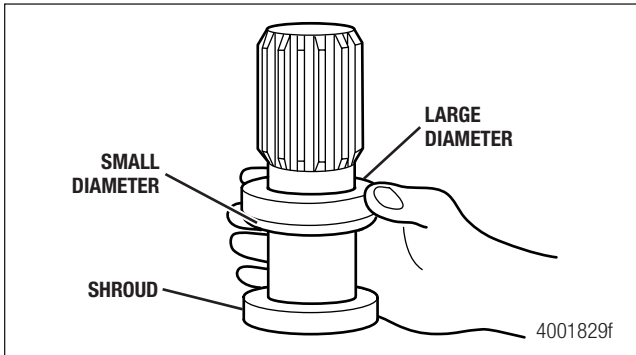

Figure 5.44

5. Align the slip yoke and spline shaft sections with the phasing marks you made on these sections during disassembly. Figure 5.45.

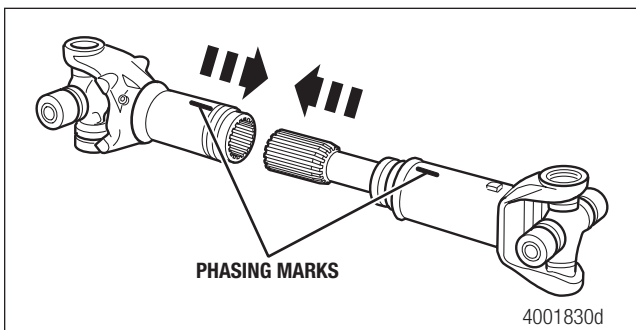

Figure 5.45

6. Install the spline shaft into the slip yoke until the splines fully engage. Figure 5.45.
7. Snap the seal into the groove. Figure 5.46.

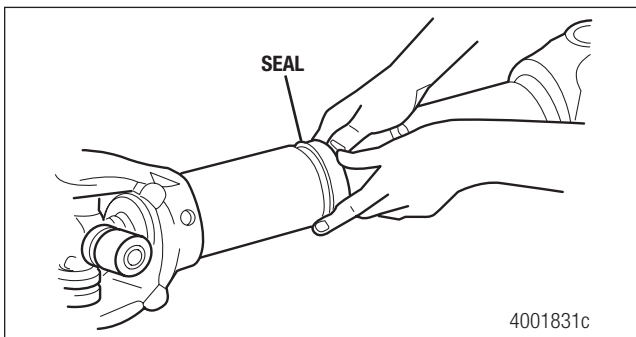

Figure 5.46

8. Snap the shroud over the seal. Figure 5.47.

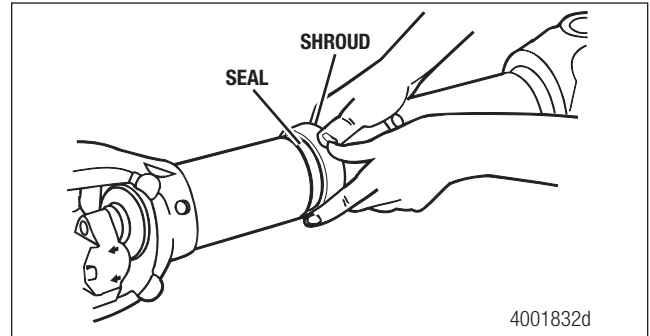

Figure 5.47

9. Push together the driveline sections. Figure 5.48.

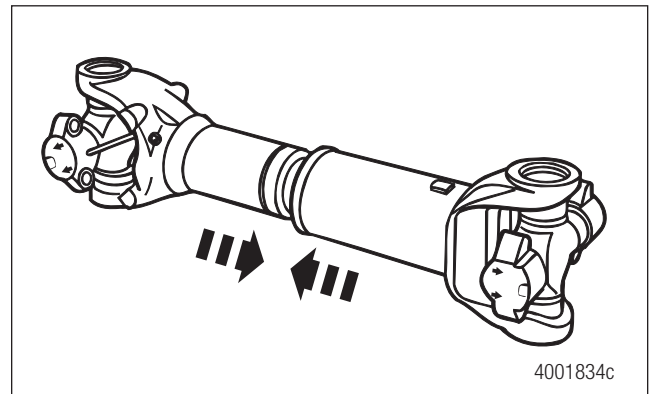

Figure 5.48

Installation

Wing Bushings

⚠ WARNING

If the universal joint and end yoke are not correctly installed, the bushings will not correctly seat in the yoke, which can cause the capscrews that secure the universal joint to fatigue under normal operating conditions. Serious personal injury and damage to components can result.

The new design wing bushing has interference bosses on the bushing. The bosses interfere with the end yoke if you attempt to install the wing bushing incorrectly. You must install the interference bosses away from the yoke. Figure 5.49.

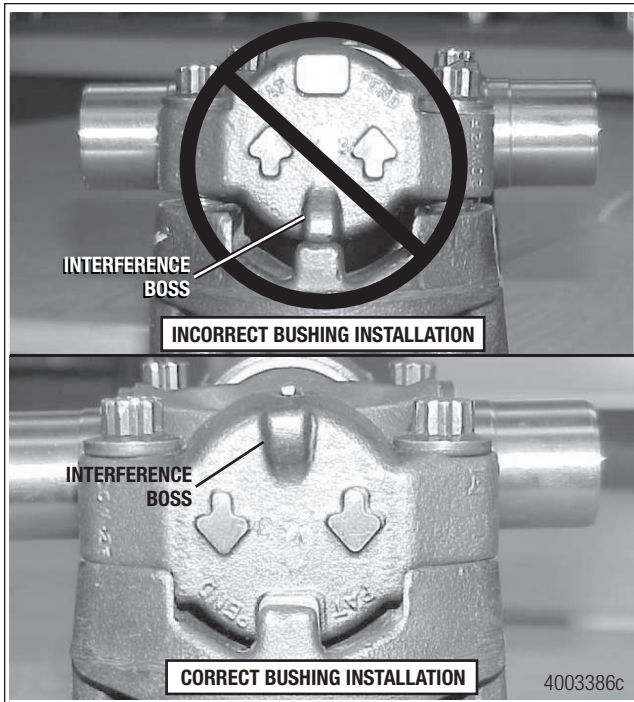

Figure 5.49

The previous design wing bushing did not have an interference boss. As a result, it was possible to insert the wing bushing into the yoke and install the pieces incorrectly. Figure 5.50.

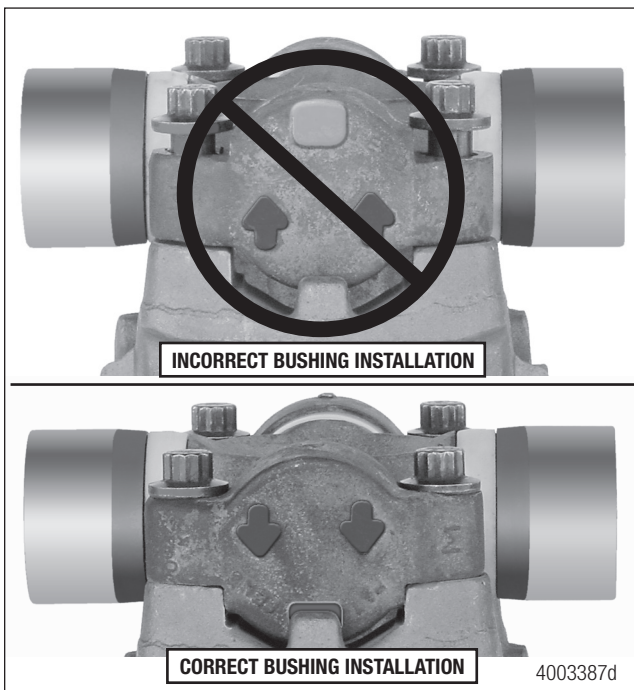

Figure 5.50

5 RPL Series Permalube

Universal Joint

⚠ CAUTION

Do not use grease or anti-seize compound in the yoke ear bores. Damage to components can result.

1. Clean dirt and contamination from the slip yoke and weld yoke ear bores. Figure 5.51.

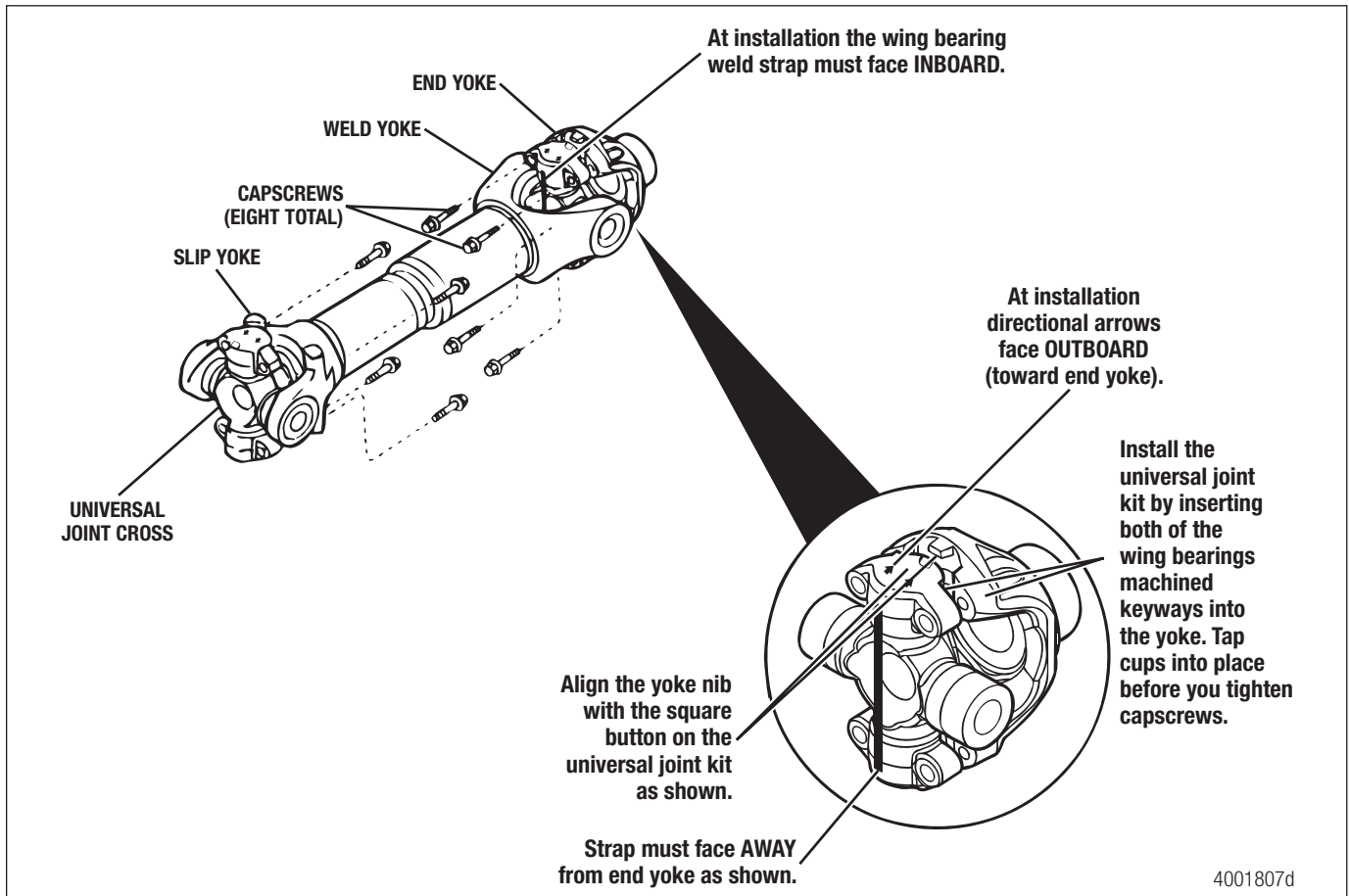

Figure 5.51

2. Install the universal joint into the yoke so that the wing bearing weld straps face INBOARD and the arrows point toward the end or coupling yokes. Figure 5.52.

5 RPL Series Permalube

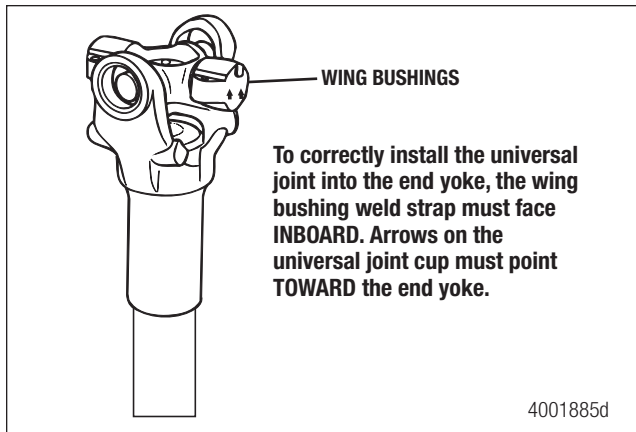

Figure 5.52

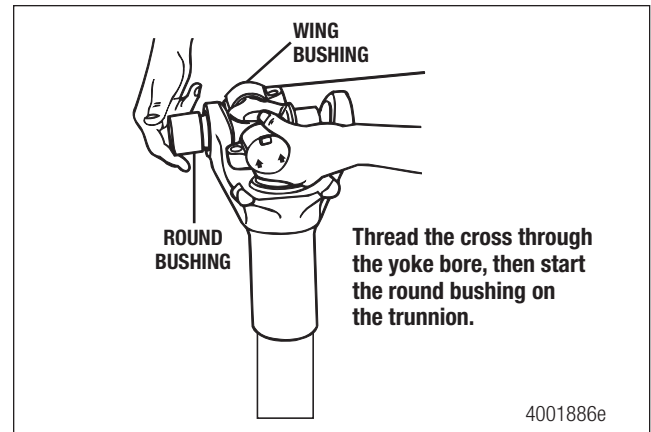

Figure 5.54

⚠ CAUTION

The universal joint is supplied with the correct amount of grease. Do not apply additional grease to the joint. Do not use grease or anti-seize compound on the outside diameter of the cups, the cross bore holes of the yoke, or the yoke saddles. Damage to components can result.

NOTE: The deflector is preassembled onto the round bushing.

- Verify that the plastic deflectors are attached to the round bushings. Figure 5.53.

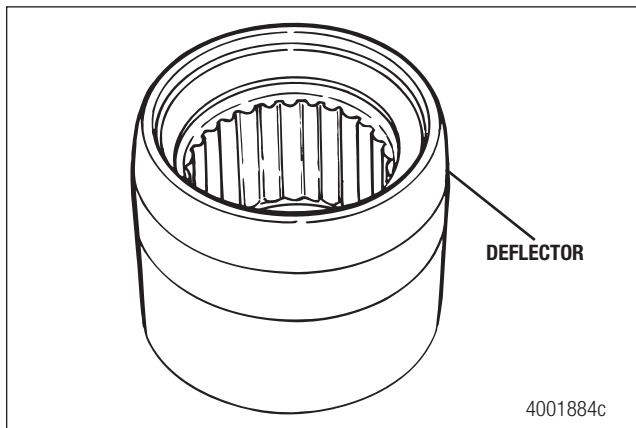

Figure 5.53

- Position the first round bushing onto the trunnion by threading the cross trunnion through the yoke bore. Figure 5.54.

⚠ DANGER

Observe all warnings and cautions provided by the press manufacturer. Failure to do so can result in death or serious personal injury and damage to components.

⚠ CAUTION

Use an arbor press, universal joint press or yoke bearing cup installation tool to install the round bushing into the yoke. Do not use a hammer, which can loosen and damage components.

NOTE: The SPX Kent-Moore press yoke bearing cup installation tool number J-44516 has a positive stop for correct installation. Refer to the Service Notes page on the front inside cover of this manual for information to obtain this tool.

- Use a press, yoke bearing cup installation tool (SPX Kent-Moore tool number J-44516) or universal joint press (Tiger Tool number 10707) to install the first round bushing slightly past the snap ring groove. When the bearing cup installation tool contacts the yoke, it is installed correctly. Figure 5.55, Figure 5.56 and Figure 5.57.

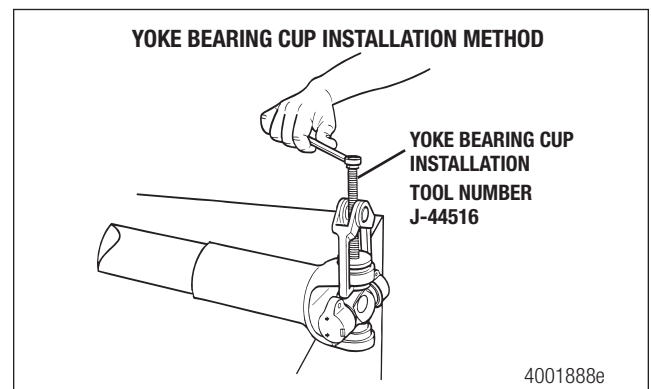

Figure 5.55

5 RPL Series Permalube

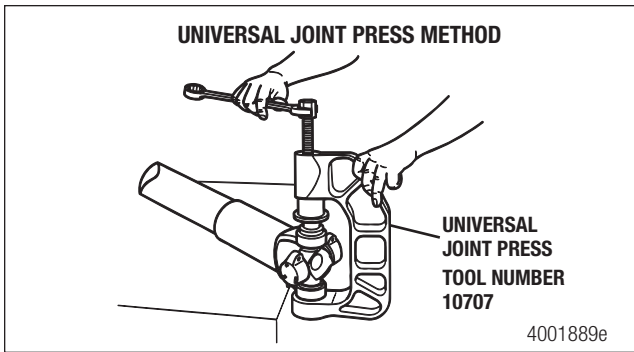

Figure 5.56

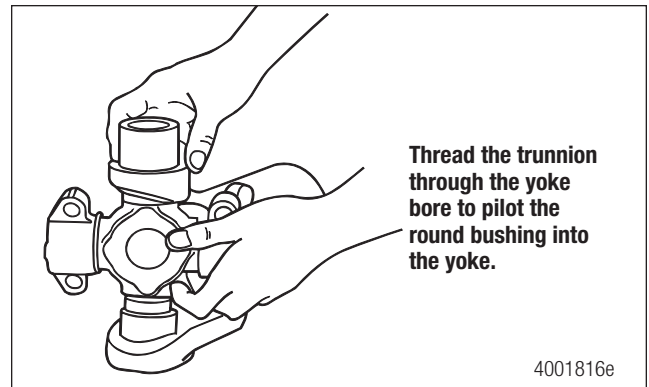

Figure 5.59

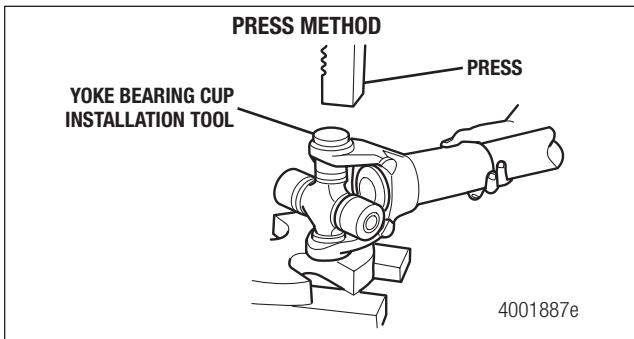

Figure 5.57

⚠ CAUTION

The snap ring must be fully seated into the snap ring groove to avoid damage to the driveline.

- Use snap ring pliers to install the snap ring into the snap ring groove. Figure 5.58. Fully seat the snap ring.

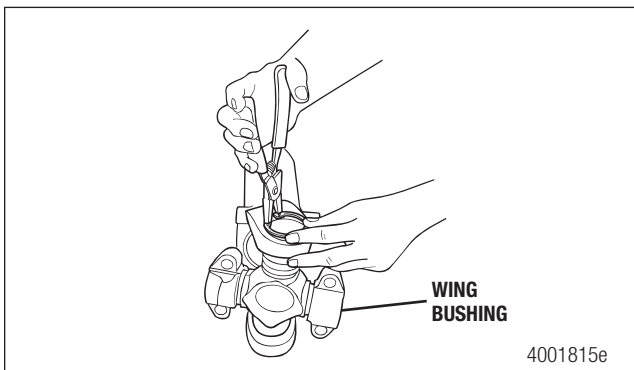

Figure 5.58

- Position the second bushing onto the trunnion by threading the cross through the yoke bore as shown. Figure 5.59.

- Use a press, yoke bearing cup installation tool (SPX Kent-Moore tool number J-44516) or universal joint press (Tiger Tool number 10707) to install the second round bushing slightly past the snap ring groove. Check that the bushing is aligned with the universal joint. Figure 5.55, Figure 5.56 and Figure 5.57.

⚠ CAUTION

The snap ring must be fully seated into the snap ring groove to avoid damage to the driveline.

- Use snap ring pliers to install the second snap ring into the snap ring groove. Figure 5.60.

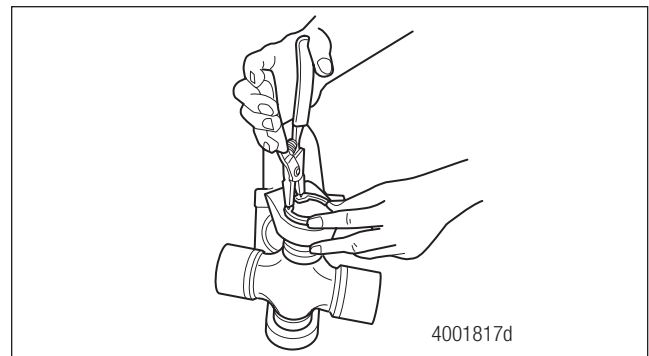

Figure 5.60

Strike the yoke ear with a brass or copper hammer to ensure that the universal joint moves freely. Figure 5.61.

5 RPL Series Permalube

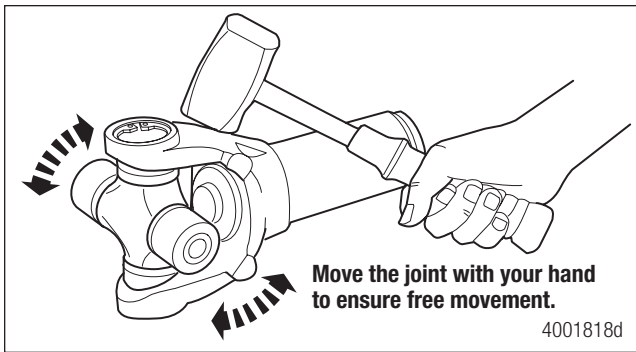

Figure 5.61

Driveline

⚠ WARNING

If the universal joint and end yoke are not correctly installed, the bushings will not correctly seat in the yoke, which can cause the capscrews that secure the universal joint to fatigue under normal operating conditions. Serious personal injury and damage to components can result.

⚠ WARNING

The wing bushing's machined keyway must be positioned against the machined keyway of the end yoke ears when installing a universal joint. Ensure that the arrows stamped on the wing bushing point TOWARD the end yoke, and the universal joint weld strap faces the driveline and AWAY from the yoke.

⚠ CAUTION

A broken weld strap can cause a wing bushing to rotate. When a bushing rotates, it's possible to assemble it into the yoke backward. To ensure correct assembly and prevent damage to components, you must insert both of the wing bushing's machined keyways into the yoke.

1. Before you install the capscrews, check that the universal joint is fully seated in the end yoke. The arrows on the wing bushing should point toward the coupling yoke. Figure 5.62.

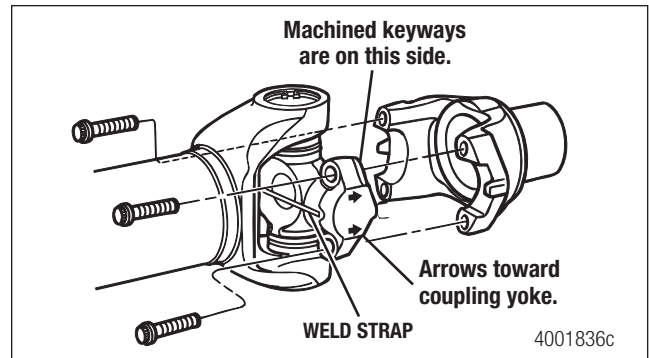

Figure 5.62

2. If necessary, tap the universal joint with a brass or copper hammer to ensure it is fully seated. Figure 5.63.

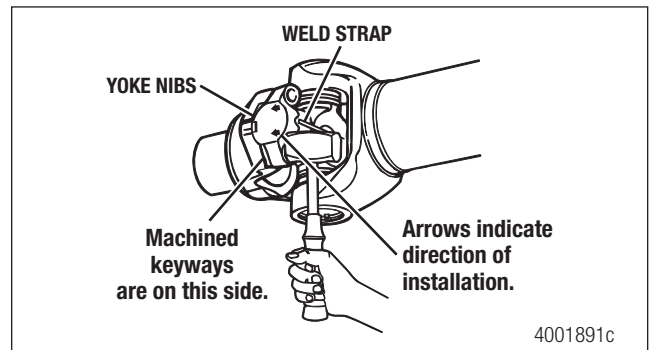

Figure 5.63

⚠ DANGER

Any time a universal joint is disconnected, new capscrews must be used during reassembly. Reusing old capscrews can cause the drive shaft to loosen or separate from the vehicle. Death or severe personal injury and damage to components can occur.

3. Install the new capscrews.
4. Use a torque wrench to alternately tighten the capscrews to 115-135 lb-ft (155-183 Nm). Figure 5.64.

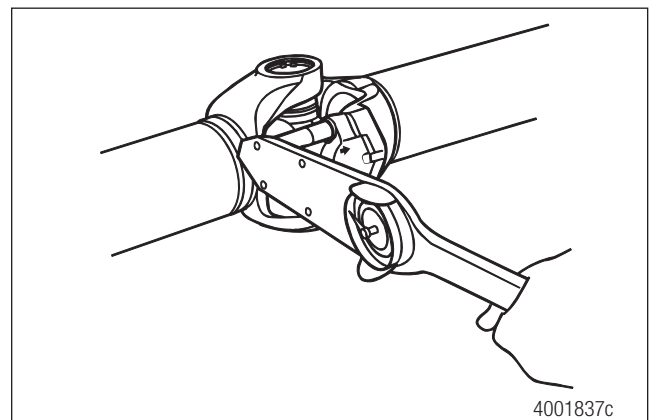

Figure 5.64

5 RPL Series Permalube

RPL35 and RPL35SD Series Permalube Procedures

The following procedures are for RPL35 and RPL35SD series Permalube drivelines. For RPL10, RPL14, RPL20, RPL25 and RPL25SD series Permalube drivelines, refer to the procedures in the first half of this section.

⚠ DANGER

Park the vehicle on a level surface. Block the wheels to prevent the vehicle from moving. Support the vehicle with safety stands. NEVER work under a vehicle supported only by jacks. Jacks can slip and fall over. Failure to use safety stands can result in death or serious personal injury and damage to components.

⚠ DANGER

Only service a driveline when the engine is OFF. A rotating driveline can result in death or serious personal injury and damage to components.

⚠ WARNING

To prevent eye injury, always wear eye protection when performing vehicle maintenance or service.

⚠ WARNING

Use a brass or synthetic mallet for assembly and disassembly procedures. NEVER hit steel parts with a steel hammer. Pieces of a part can break off. Serious personal injury and damage to components can result.

⚠ WARNING

Only install the correct grade new bearing retainer bolts and stamped strap bolts. Do not reuse these parts. If the bearing retainer straps are damaged, install new retainers. Damaged and reused parts can affect driveline operation, which can cause the driveline to separate from the vehicle. Serious personal injury and damage to components can result.

⚠ WARNING

A driveline assembly can weigh more than 100 pounds (46 kilograms). Always use lifting devices and the correct procedures when handling drivelines to prevent serious personal injury and damage to components.

Removal

Driveline

1. Park the vehicle on a level surface. Release the parking brake to allow the driveline to rotate freely. Block the wheels to keep the vehicle from moving. Raise the vehicle so that the area you will service is off the ground. Support the vehicle with safety stands.
2. Apply reference marks at the flange connections on both ends. These marks will be used to reinstall the driveline with the same phasing at reassembly. Figure 5.65.

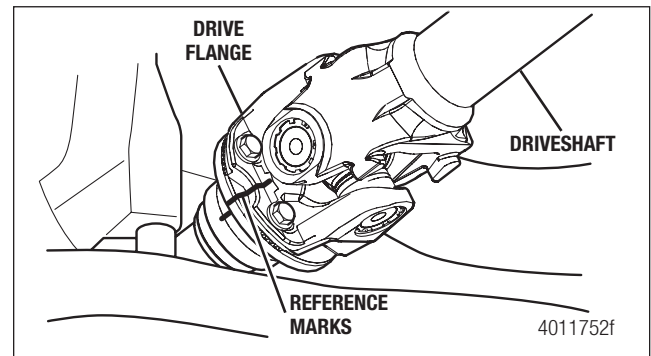

Figure 5.65

3. Remove the fasteners and separate the drive flange from the input drive flange. Support the disconnected end of the driveline. Figure 5.66.

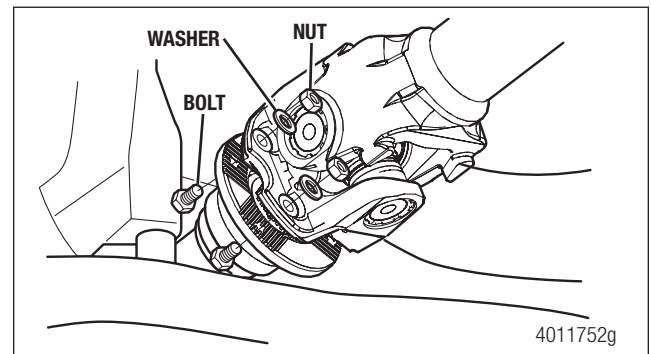

Figure 5.66

4. Remove the fasteners and separate the coupling joint flange from the rear drive flange. Support the disconnected end of the driveline.
5. Lower the driveline onto a transmission jack equipped with suitable adapters and remove the driveline from the vehicle.

5 RPL Series Permalube

Universal Joint

1. Use snap ring pliers to remove the snap rings that secure the drive flange to the cross. Figure 5.67.

If the snap ring is difficult to remove: Use a brass drift and hammer to lightly tap the center of the bushing to assist snap ring removal.

If the snap ring is still difficult to remove: Use an appropriate size sleeve and press to press down lightly on the bearing. This will create more space between the drive flange and the bearing so the snap ring can be dislodged from the groove easier.

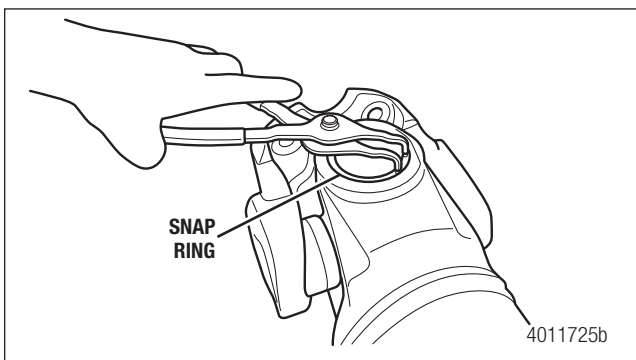

Figure 5.67

2. Repeat the previous step on the other side of the drive flange.
3. Install a press bridge tool (SPX ICM Kent-Moore tool number J-42368-1) on the ears of the drive flange and a bearing cup bushing receiver (SPX Kent-Moore tool number J-42368-2) underneath. Figure 5.68.

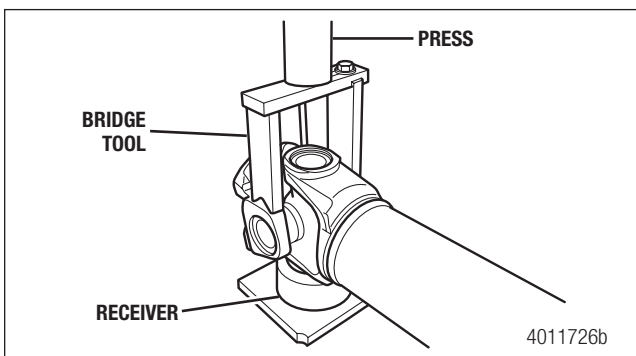

Figure 5.68

4. Press DOWN until the first bushing loosens and is exposed.

NOTE: The plastic deflectors adjacent to the cross will become damaged from the press procedure. Remove the plastic deflectors and discard them. Figure 5.69.

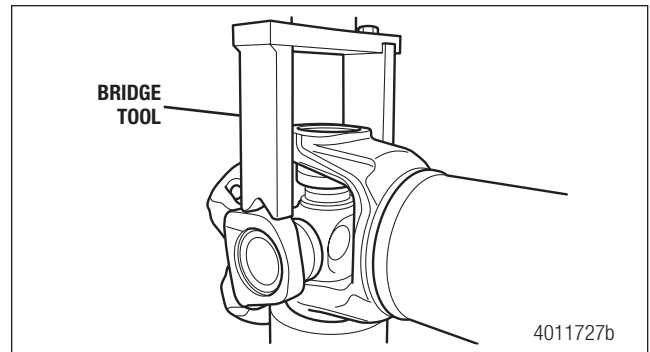

Figure 5.69

5. Rotate the universal joint 180 degrees to the other end. Figure 5.70.

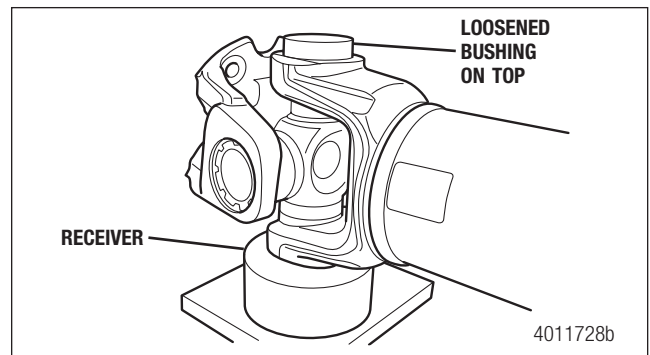

Figure 5.70

6. Repeat Steps 3 and 4 to press the bushing/bearing assembly. Press DOWN until the second bushing loosens and is exposed.
7. Lift up the cross and install the half-round sleeves on the radius of the bottom trunnion as shown. Refer to Section 16 for a tool drawing. Figure 5.71 and Figure 5.72.

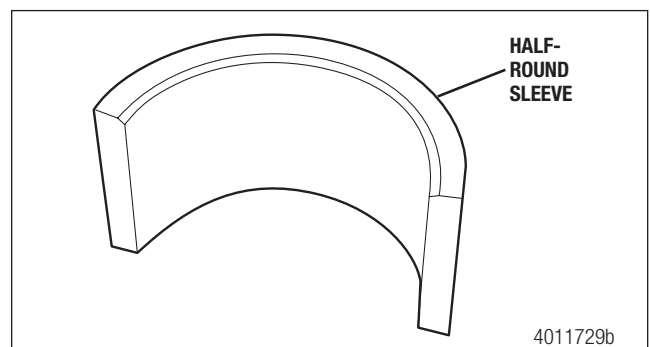

Figure 5.71

5 RPL Series Permalube

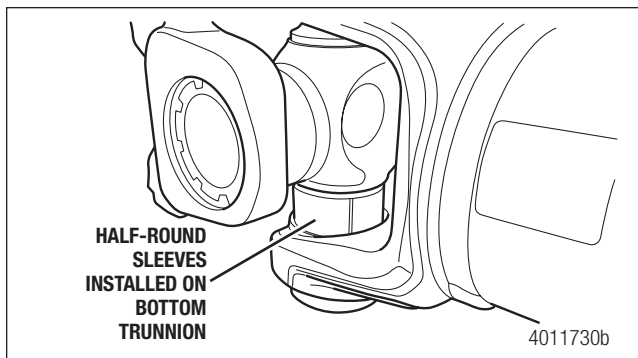

Figure 5.72

8. Install the drive flange assembly back into the bearing cup receiver. Refer to Section 16 for a tool drawing, Figure 5.73.

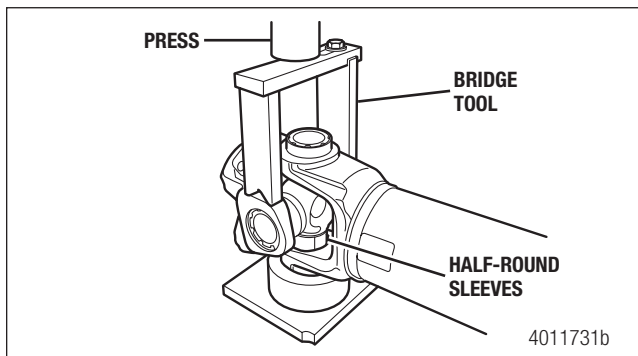

Figure 5.73

9. Install the press bridge tool on the ears of the drive flange and use a press to press DOWN. Figure 5.74.

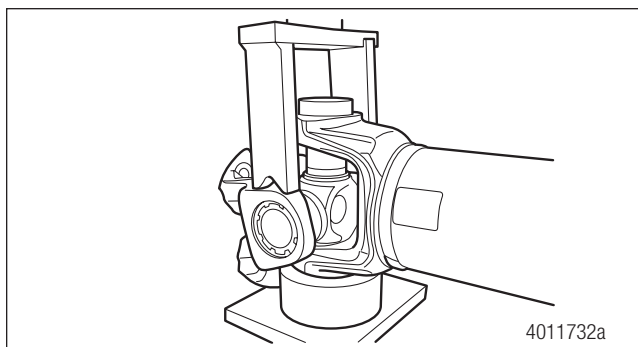

Figure 5.74

10. Remove the half-round sleeves from the trunnion and remove the bushing/bearing assembly from the receiver.
11. Install the half-round sleeves on the radius of the top trunnion. Figure 5.75.

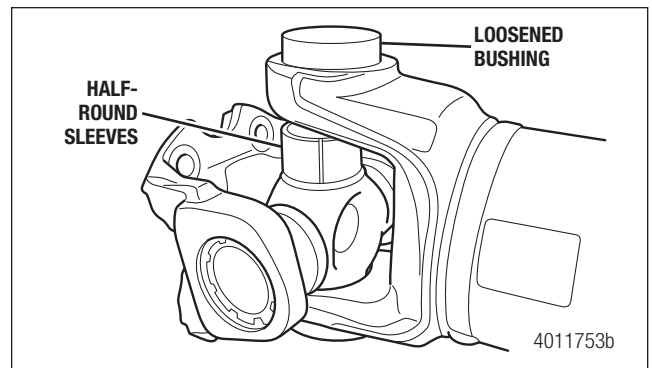

Figure 5.75

12. Turn the drive flange assembly over (rotate it 180 degrees) and lower it into the receiver.
13. Install the press bridge tool and press DOWN. Remove the half-round sleeves from the trunnion and the bushing/bearing assembly from the receiver. Figure 5.76 and Figure 5.77.

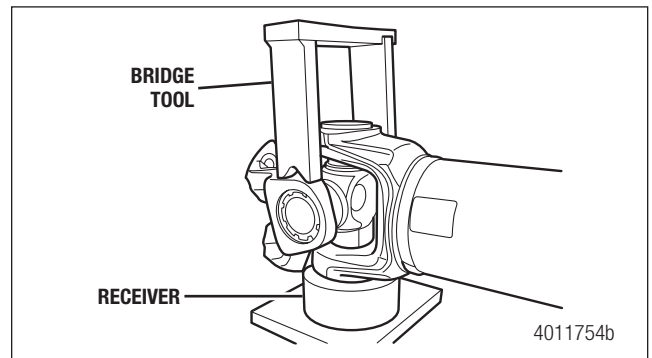

Figure 5.76

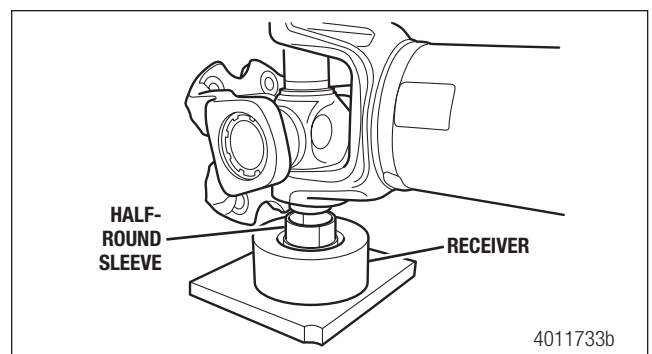

Figure 5.77

5 RPL Series Permalube

14. Remove the drive flange and cross from the driveline.
Figure 5.78.

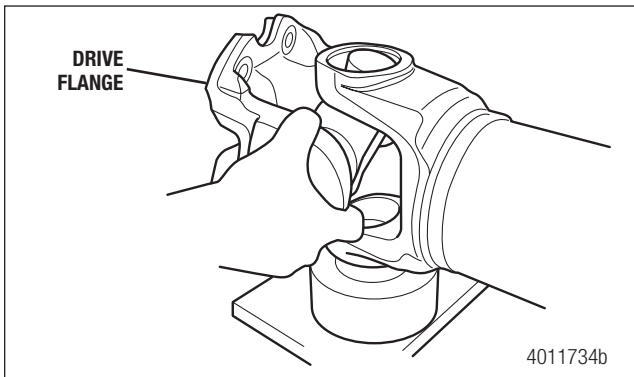

Figure 5.78

15. Use the same procedure to remove the snap rings and bushing/bearing assemblies from both ends of the cross and remove the cross from the drive flange assembly.

Cross

1. Use snap ring pliers to remove the snap rings that secure the drive flange to the cross.
2. Place the drive flange in the receiver cup. Install the press bridge tool on the trunnions. Figure 5.79.

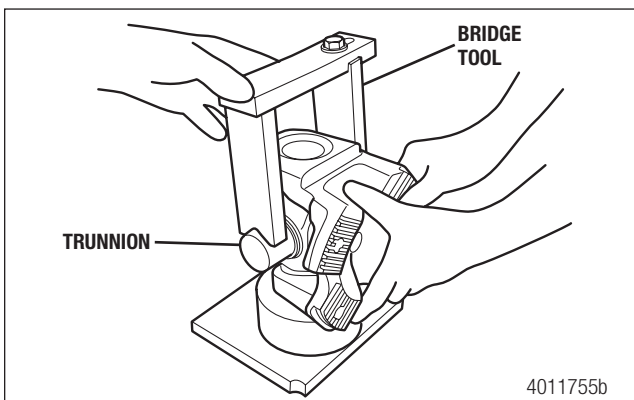

Figure 5.79

3. Press DOWN to press the cross free.
4. Rotate the drive flange 180 degrees (to the other end). Install the press bridge tool and press DOWN.
5. Install half moons on the top universal joint radius, then turn it over.
6. Install the press bridge tool and press DOWN. Figure 5.80.

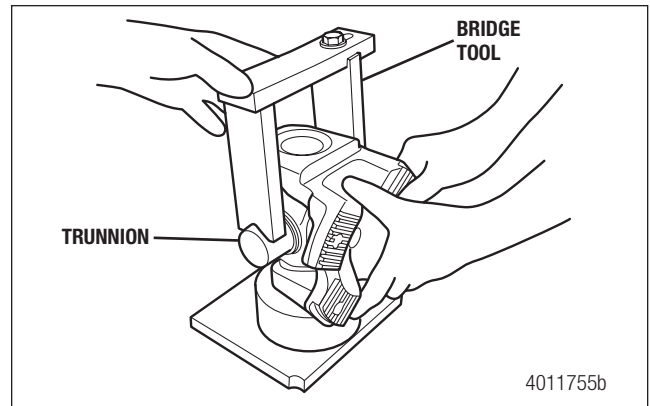

Figure 5.80

7. Remove the half-round sleeves and remove the bushing/bearing assembly.
8. Rotate the drive flange 180 degrees (to the other end). Install the half-round sleeves on the bottom universal joint radius. Figure 5.81.

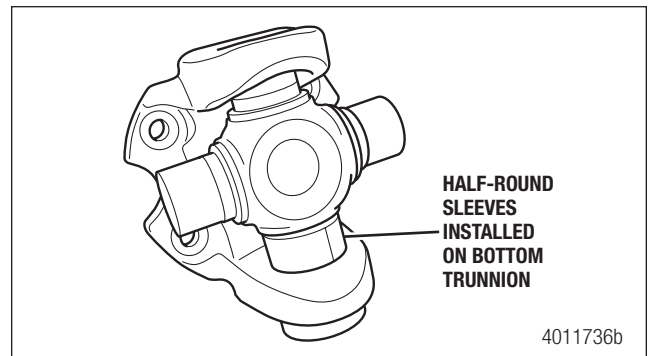

Figure 5.81

9. Install the press bridge tool and press DOWN until the cross is pressed out.
10. Remove the bushing/bearing assembly and the half-round sleeves. Remove the cross from the drive flange. Figure 5.82.



Figure 5.82

5 RPL Series Permalube

Coupling Joint Flange

1. Use a suitable fixture or method to immobilize the drive flange end so the coupling joint end will not rotate.
2. Use a socket to remove the nut from the coupling joint flange.
3. Remove the coupling joint flange from the driveline.

Assembly

Drive Flange

1. Ensure the snap ring grooves are clean and free of debris and clean if necessary. If the groove has debris, the snap ring will not seat correctly.
2. Insert the bushing on the bottom of the joint. Figure 5.83.

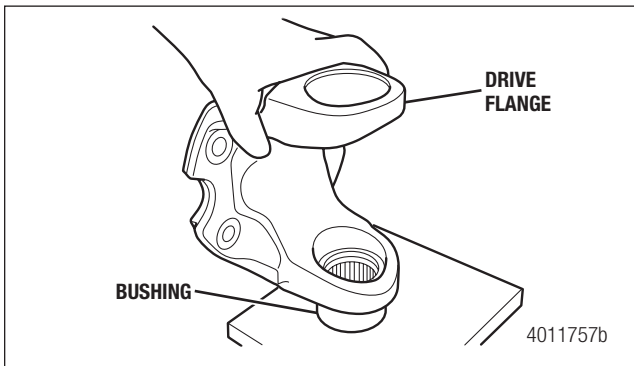

Figure 5.83

3. Install the cross into the drive flange. Figure 5.84.

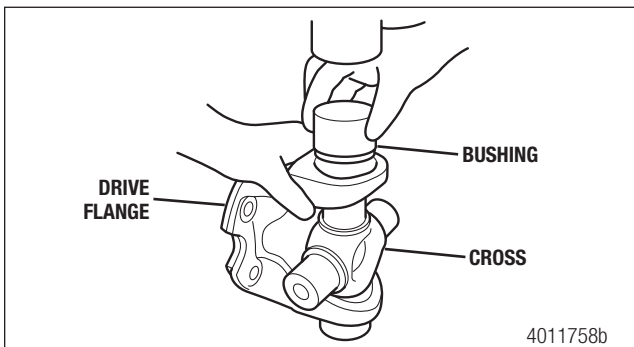

Figure 5.84

4. Install the bushing on top of the cross and drive flange.

⚠ CAUTION

Ensure the universal joint and the bushings being installed are aligned before applying pressure. If the components are not aligned, damage to the universal joint or bushings can result.

5. Verify the universal joint is positioned straight in the press and is not cocked. Ensure the universal joint and the bushings being installed are aligned before applying pressure. Press down on the top bearing to install it down into the yoke hole and onto the cross. Figure 5.85.

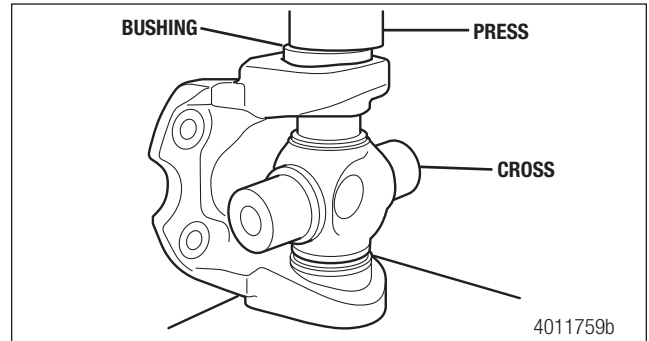

Figure 5.85

6. Install a cylinder and continue pressing down until the bushing is seated low enough to install the snap ring. Figure 5.86.

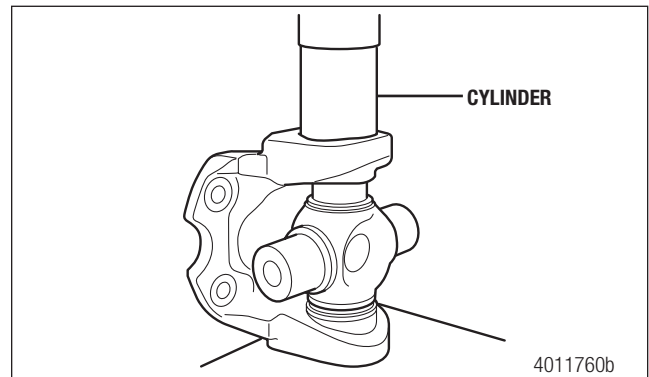

Figure 5.86

7. Install the new snap ring. Ensure it is seated all the way around the groove. Use a drift and hammer if needed to seat it in the groove all the way around. If the snap ring will not seat correctly, make sure the snap ring groove is clean and free of debris. Figure 5.87 and Figure 5.88.

NOTE: The gap between the snap ring ends is smaller when the snap ring is not completely seated. Once correctly seated, the snap ring will expand in the groove and the ends of the snap ring will spread further apart. Figure 5.89 and Figure 5.90.

5 RPL Series Permalube

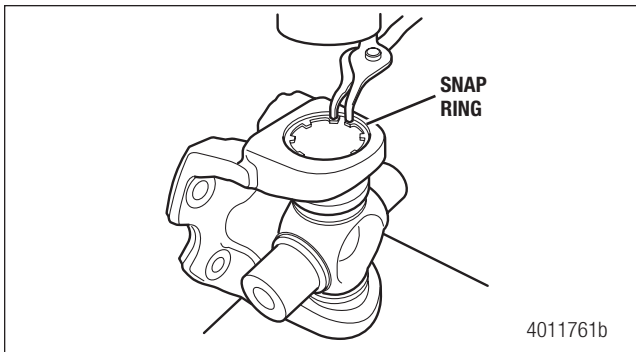

Figure 5.87

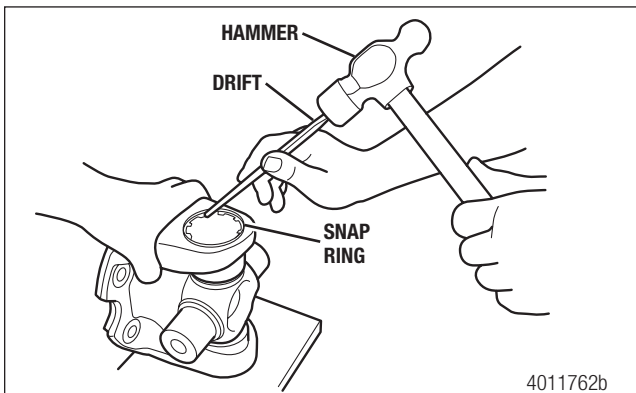

Figure 5.88

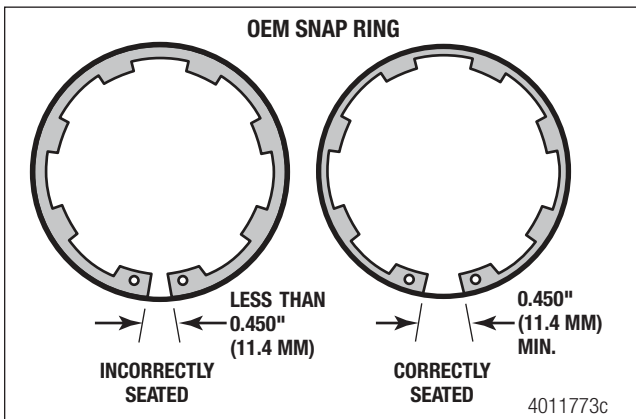

Figure 5.89

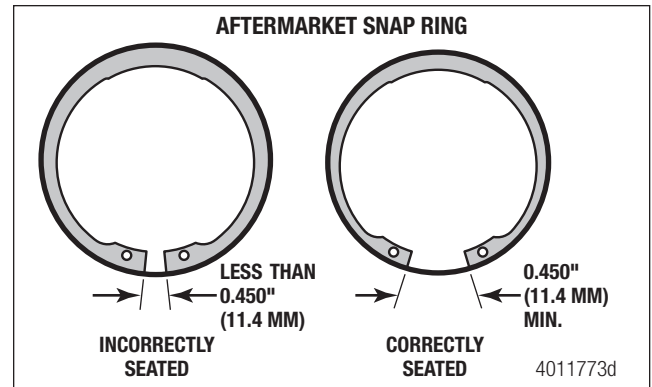

Figure 5.90

8. Rotate the drive flange 180 degrees.
9. Install the cylinder on the end and press DOWN until there is snap ring clearance. Apply only the amount of pressure needed to push the bearing down. Excess pressure may cause damage to the snap ring installed on the other end. Figure 5.91.

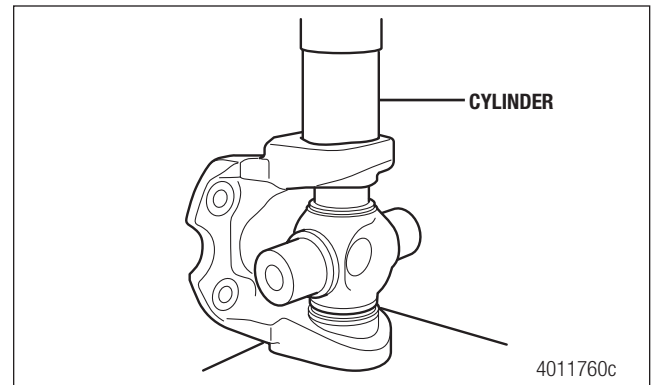

Figure 5.91

10. Install the snap ring. Ensure it is seated all the way around the groove. Use a drift and hammer if needed to seat it in the groove all the way around. If the snap ring will not seat correctly, make sure the snap ring groove is clean and free of debris. Figure 5.92.

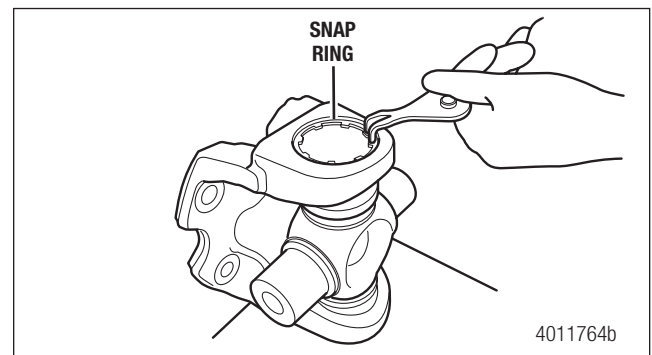

Figure 5.92

5 RPL Series Permalube

Installation

Drive Flange

1. Ensure the snap ring grooves are clean and free of debris and clean if necessary. If the groove has debris, the snap ring will not seat correctly.
2. Install the bushing in the bottom of the yoke. Figure 5.93.

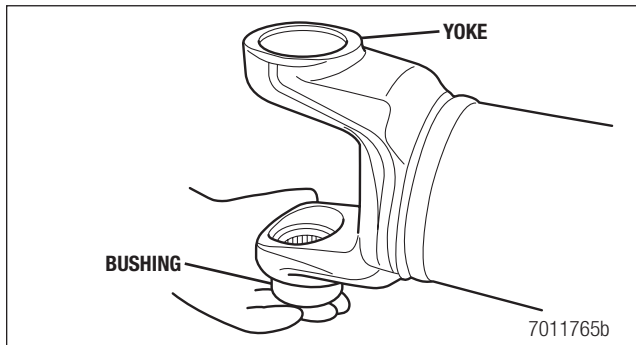

Figure 5.93

3. Install the flange assembly into the universal joint. Install the side without the cup first in the top then seat the rest down into the bottom. Figure 5.94.

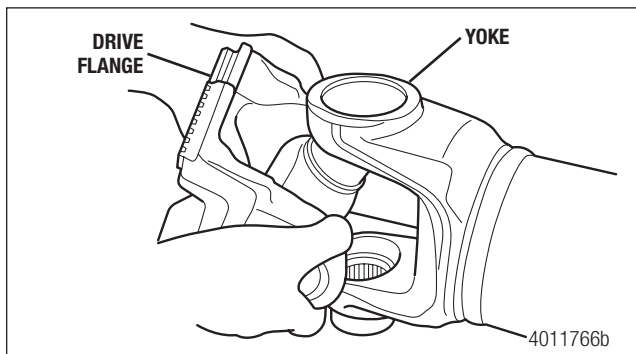

Figure 5.94

4. Install the bushing on top. Figure 5.95.

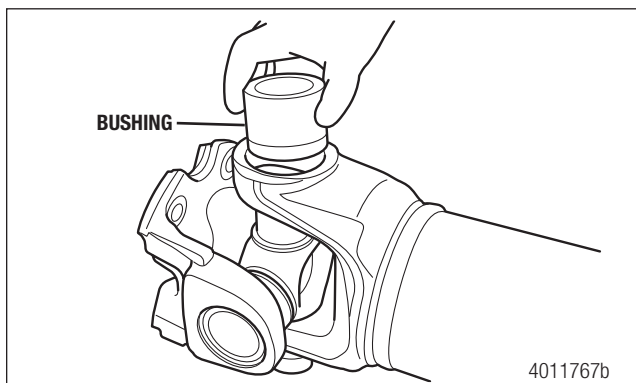

Figure 5.95

5. Use a press to press the top bushing/bearing assembly DOWN. Make sure the yoke is level so the bushing will be pressed straight down. Figure 5.96.

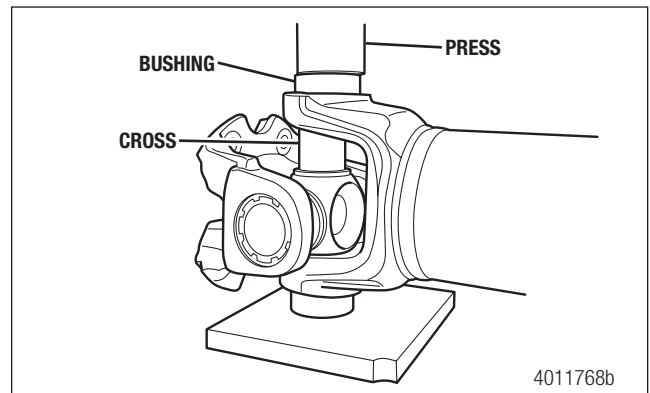

Figure 5.96

6. Tap on the ears of the yoke and move the cross to loosen up the parts after installation and ensure they move freely.
7. Install the cylinder to press the bushing/bearing assembly down so there is enough clearance for the snap ring to be installed. Figure 5.97.

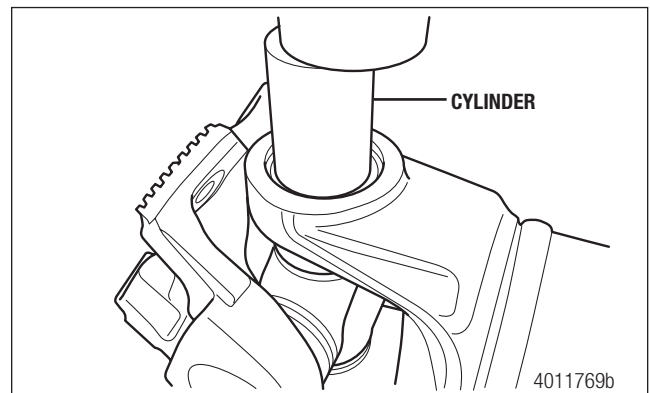

Figure 5.97

8. Install the snap ring. If necessary, use a drift and hammer help seat the snap ring in the groove. If the snap ring will not seat correctly, make sure the snap ring groove is clean and free of debris. Figure 5.98.

NOTE: The gap between the snap ring ends is smaller when the snap ring is not completely seated. Once correctly seated, the snap ring will expand in the groove and the ends of the snap ring will spread further apart.

5 RPL Series Permalube

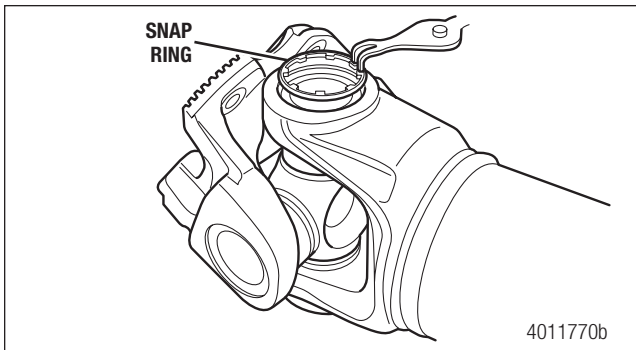

Figure 5.98

9. Rotate the assembly 180 degrees (turn it over). Figure 5.99.

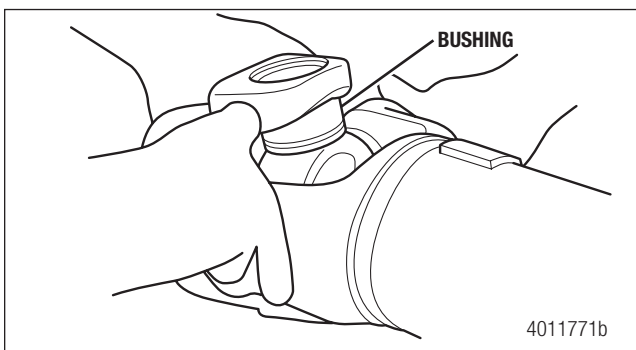

Figure 5.99

10. Install the cylinder and press down to create clearance for snap ring installation. Figure 5.100.

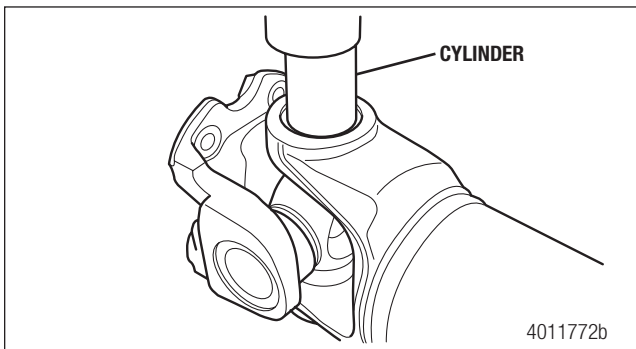

Figure 5.100

11. Install the snap ring. If necessary, use a drift and hammer (suitable tool and mallet) to seat the snap ring in the groove. If the snap ring will not seat correctly, make sure the snap ring groove is clean and free of debris.
12. After assembly, strike the ears of the yoke with a brass mallet to relieve the stress and free up the cross joint. Move it by hand to ensure it moves freely.

Coupling Joint Flange

1. Use a suitable fixture or method to immobilize the drive flange end so the coupling joint end will not rotate.
2. Install the coupling joint flange onto the driveline.
3. Install the nut on the coupling joint flange.
4. Use a socket to tighten the nut to 450-600 lb-ft (610-813 Nm).

Driveline

1. Raise the driveline and position it to the vehicle.
2. Align the driveline drive flange to the vehicle input drive flange according to the reference marks made during removal. The driveline must be reinstalled with the same phasing. Figure 5.101.

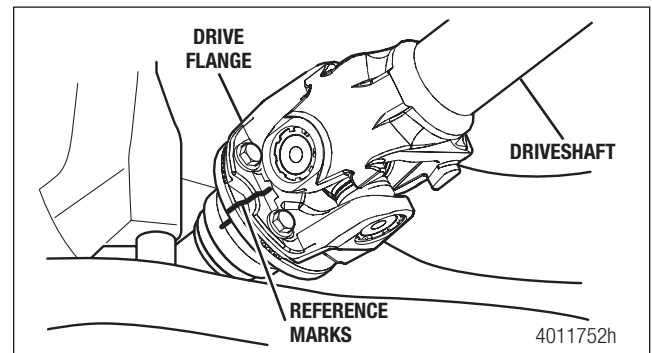

Figure 5.101

⚠ DANGER

Any time a universal joint is disconnected, new cap screws must be used during reassembly. Reusing old fasteners can cause the drive shaft to loosen or separate from the vehicle. Death or severe personal injury and damage to components can occur.

3. Install the new bolts, washers and nuts to secure the drive flange to the input drive flange. Tighten the nuts to 133-163 lb-ft (180-220 Nm). Figure 5.102.

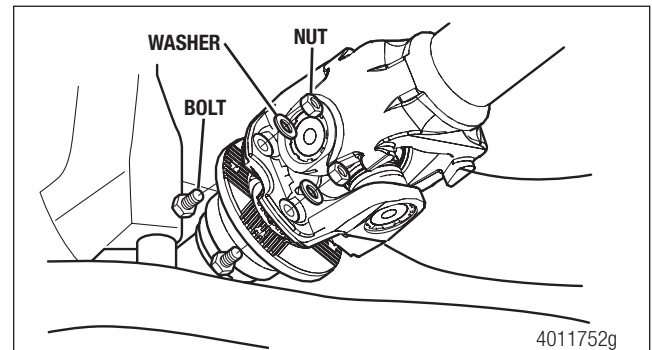

Figure 5.102

5 RPL Series Permalube

4. Align the driveline coupling joint flange to the vehicle rear drive flange according to the reference marks made during removal. The driveline must be reinstalled with the same phasing.
5. Install the fasteners and washers to secure the coupling joint flange to the vehicle rear drive flange. Figure 5.103. Due to tight clearances, some applications may require the bolt to be inserted from the yoke flange side without a washer and secured with a nut on the drive flange side. Figure 5.104. Tighten the fasteners to 133-163 lb-ft (180-220 Nm).

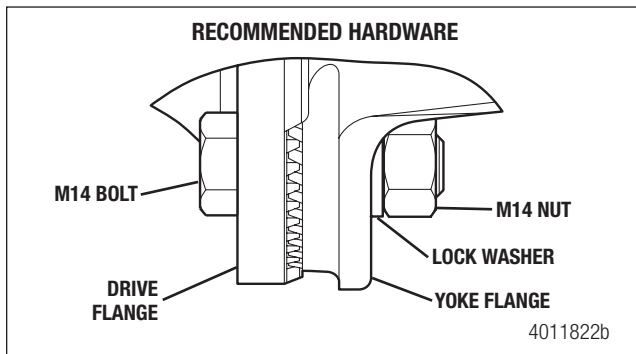

Figure 5.103

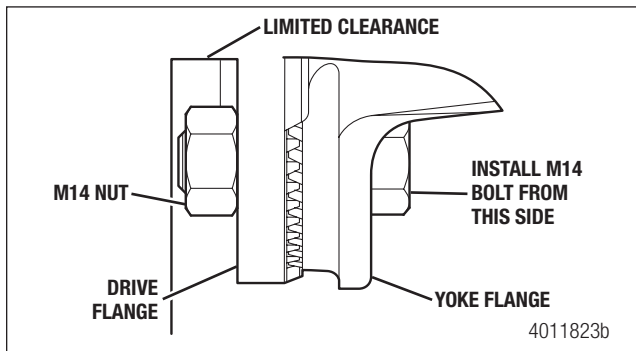

Figure 5.104

Full-Round

Hazard Alert Messages

Read and observe all hazard alert messages in this publication.

⚠ DANGER

Park the vehicle on a level surface. Block the wheels to prevent the vehicle from moving. Support the vehicle with safety stands. NEVER work under a vehicle supported only by jacks. Jacks can slip and fall over. Failure to use safety stands can result in death or serious personal injury and damage to components.

⚠ DANGER

Only service a driveline when the engine is OFF. A rotating driveline can cause serious personal injury and damage to components.

⚠ WARNING

To prevent eye injury, always wear eye protection when performing vehicle maintenance or service.

Removal

Driveline

1. Park the vehicle on a level surface. Release the parking brake to allow the driveline to rotate freely. Block the wheels to keep the vehicle from moving. Raise the vehicle so that the area to be serviced is off the ground. Support the vehicle with safety stands.
2. Loosen and remove the capscrews from the end yoke bearing cups.
3. Remove the first bearing cup. If necessary, use a bearing puller to remove the bearing cup from the yoke bore. Figure 6.1.

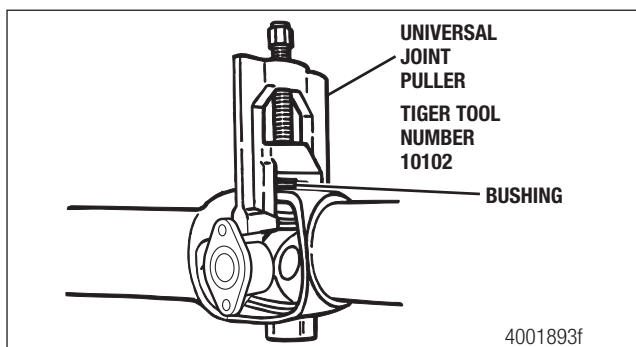

Figure 6.1

4. Remove the second bearing cup. Figure 6.2.

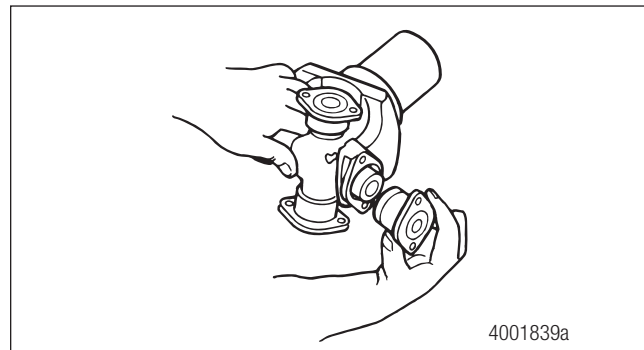

Figure 6.2

NOTE: Support the driveline when you remove it from the end yoke.

5. Slide the yoke to one side until you can work a trunnion free from the yoke bore.
6. Slide the yoke in the OPPOSITE direction while removing the universal joint from the end yoke.
7. Repeat Step 2 to Step 6 to separate the slip yoke end of the driveline.

Universal Joint

1. Loosen and remove the capscrews from the two remaining bearing cups on the yoke end of the driveline.
2. Remove the bearing cups. If necessary, use a commercial bearing puller to remove the bearing cups from the yoke bores.
3. Work the trunnions free of the yoke bores. Remove the universal joint cross from the weld yoke.
4. Repeat Step 1 to Step 3 to remove the universal joint cross from the slip yoke.

Disassembly

Slip Yoke

1. Use a brass or copper hammer and a drift to tap the shroud off the slip seal.
2. Use a screwdriver to pry the seal out of the groove in the slip yoke. Figure 6.3.

6 Full-Round

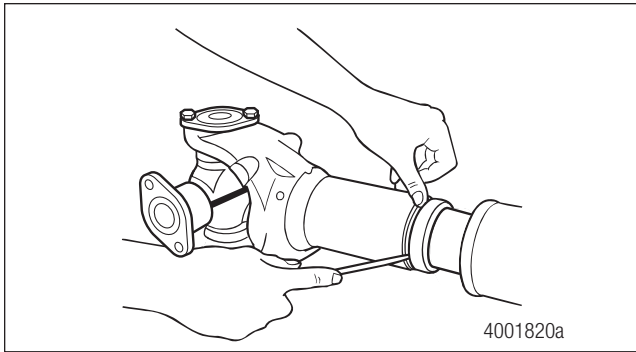

Figure 6.3

3. Mark the slip yoke and slip shaft sections to ensure that you reassemble them into their original positions. Figure 6.4.

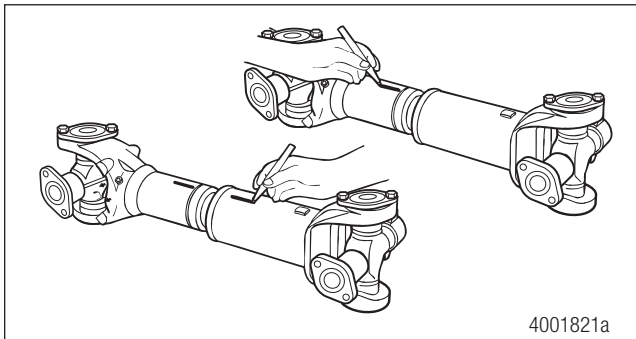

Figure 6.4

4. Pull the slip yoke and slip shaft sections apart. Figure 6.5.

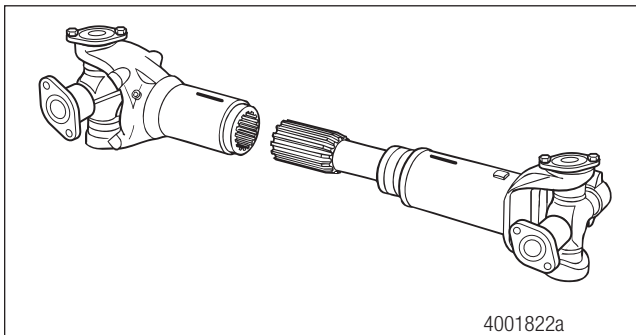

Figure 6.5

5. Remove the seal and shroud. Figure 6.6 and Figure 6.7.

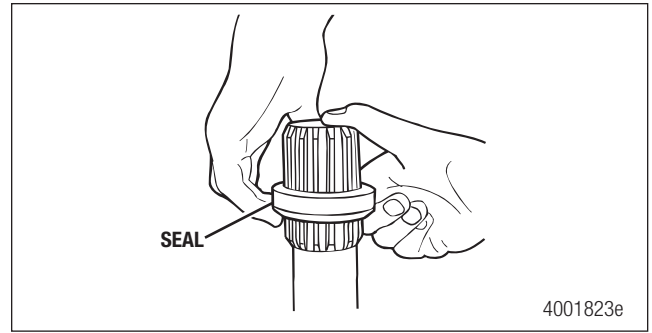

Figure 6.6

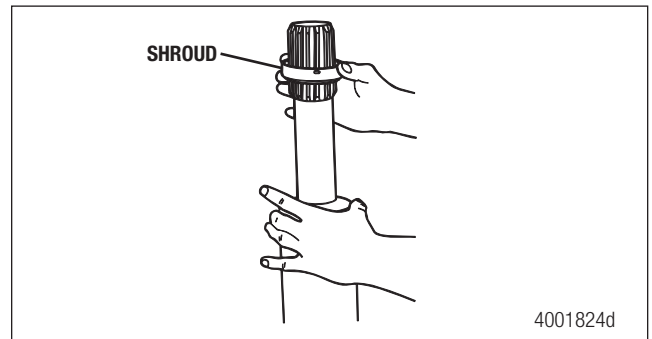

Figure 6.7

Installation

Slip Yoke

1. Install the shroud onto the slip shaft. Figure 6.8.

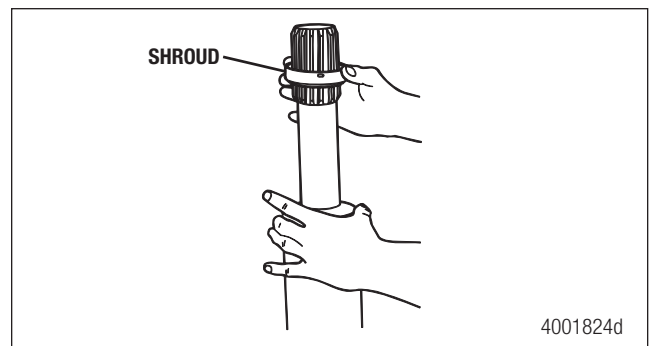

Figure 6.8

2. Install the new seal onto the spline shaft neck. Ensure that the small diameter side fits onto the splines first. Figure 6.9.

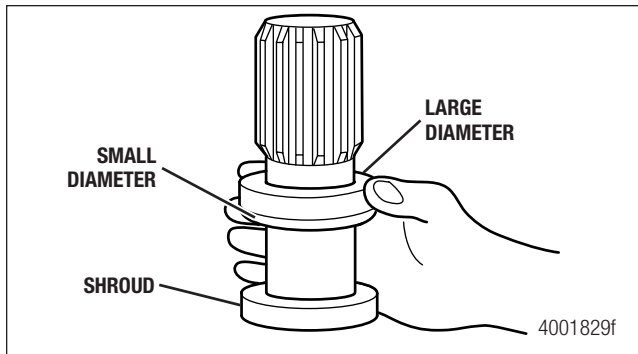

Figure 6.9

3. Install the slip shaft into the slip yoke. Ensure that you reassemble the sections into their original positions by using the marks made during disassembly. Figure 6.10.

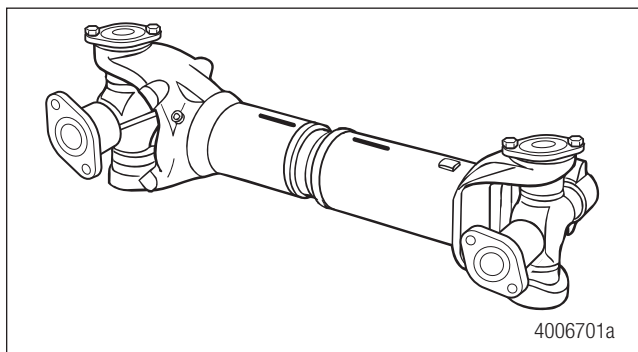

Figure 6.10

4. Install the seal onto the groove in the slip yoke. Figure 6.11.

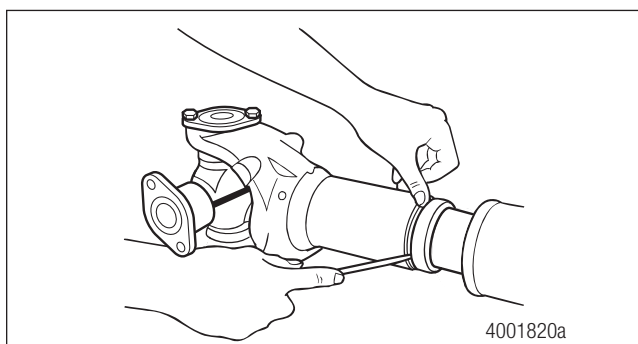

Figure 6.11

5. Snap the shroud over the seal.

Universal Joint

⚠ WARNING

Use a brass or synthetic mallet for assembly and disassembly procedures. NEVER hit steel parts with a steel hammer. Pieces of a part can break off. Serious personal injury and damage to components can result.

1. Install the universal joint cross into the yoke.
2. Install the two bearing cups through the yoke bores and onto the universal joint cross trunnions. If necessary, use a copper or brass hammer to tap the bearing caps until they are fully seated.
3. Hand-tighten the capscrews through the bearing cover plate and into the slip yoke.
4. Use a torque wrench to alternately tighten the capscrews to the correct specifications. Refer to Table B: Torque Specifications – Full-Round.
5. Repeat Step 1 to Step 3 to install the universal joint cross into the weld yoke.

Driveline

1. Wipe off the end yoke bearing bores. Insert the trunnion through the yoke bore.
2. Check the bearing cup to ensure that the needle bearings are in place. Replace the bearing cup when the needle bearings are missing or out of place.
3. Hold the cross. Use a copper or brass hammer to lightly tap the bearing cup completely into the yoke bore. Figure 6.12.

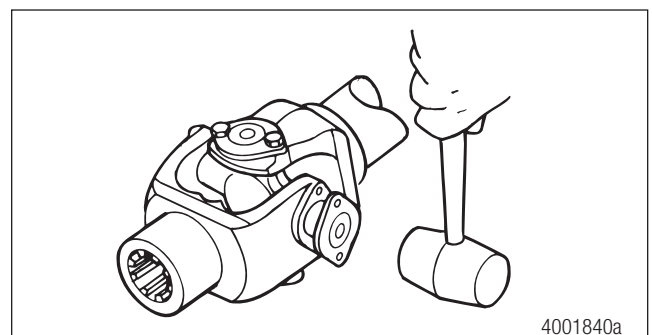

Figure 6.12

4. Align the cover plate holes and the yoke ear. Figure 6.13. Install the bearing cover plate flush against the milled surface of the yoke.

6 Full-Round

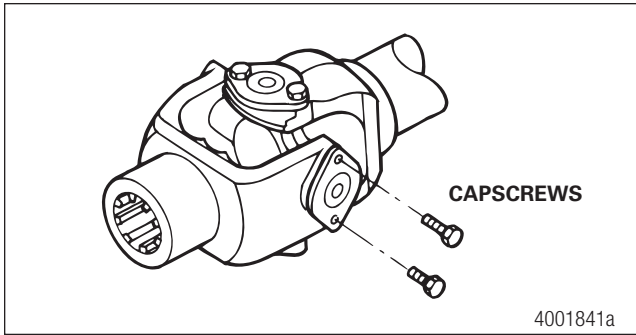

Figure 6.13

⚠ DANGER

Any time a universal joint is disconnected, new cap screws must be used during reassembly. Reusing old cap screws can cause the drive shaft to loosen or separate from the vehicle. Death or severe personal injury and damage to components can occur.

5. Install new cap screws and hand-tighten them through the bearing cover plate and into the yoke.
6. Repeat Step 2 to Step 5 to install the second bearing cup.

If the cover plate will not seat flush against the yoke surface: Remove each bearing cup from the yoke bore. Check the bottom of each bearing cup. If you find a needle bearing, replace the bearing cup.

7. Use a torque wrench to alternately tighten the cap screws to correct specifications. Refer to Table B: Torque Specifications – Full-Round. Figure 6.14.

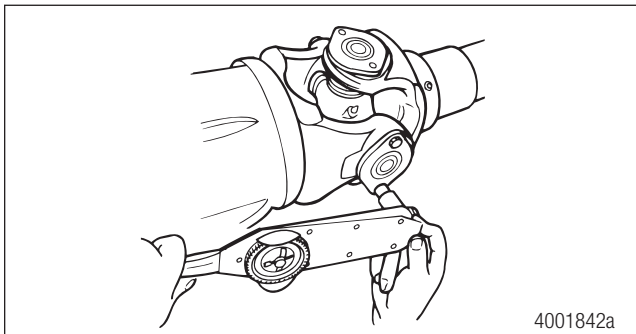
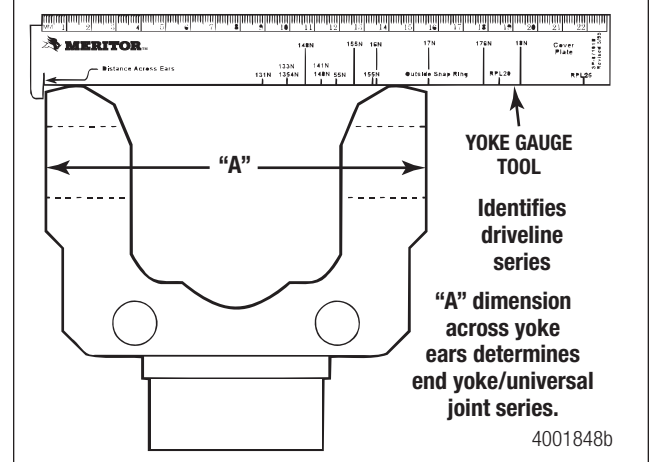

Figure 6.14

Table B: Torque Specifications – Full-Round

Driveline Series	"A" Inches (mm)	Thread Size Inches	Torque Specs lb-ft (Nm)
16N	5.31 (134.87)	5/16-24	26-35 (35-47)
17N	6.09 (154.69)	3/8-24	38-48 (51-65)
176N	7.00 (177.8)	3/8-24	38-48 (51-65)
18N	7.55 (191.77)	3/8-24	38-48 (51-65)



Lubrication

Universal Joint

After installation into the end yokes, lubricate the universal joints at the grease fitting until grease flows from the bearing cup seals on all four trunnions. Use Meritor grease specification O-634-B, NLGI Grade 2 with EP additive. Figure 6.15.

If grease does not purge from the seals: Follow the steps below.

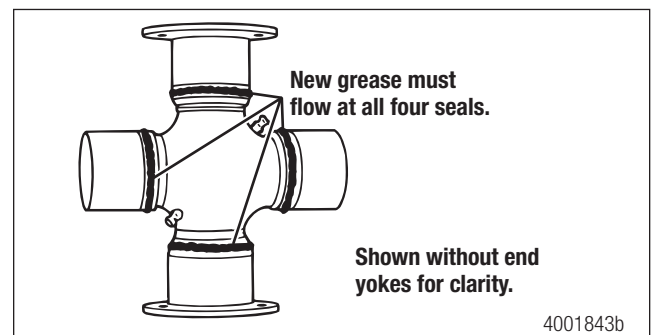

Figure 6.15

- a. Move the assembly UP-AND-DOWN or SIDE-TO-SIDE while you apply grease gun pressure. Figure 6.16.

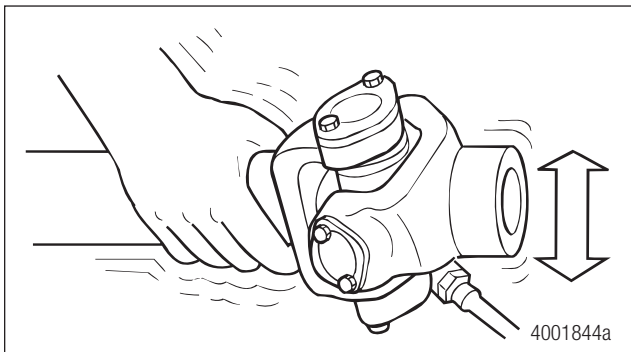

Figure 6.16

- b. Loosen the bearing cup capscrews. Add grease until grease purges from the seals.

If grease still does not purge from all four trunnion seals: Remove the universal joint and correct the problem.

If you cannot determine the problem: Replace the universal joint.

- c. Tighten the capscrews. Refer to Table B: Torque Specifications – Full-Round.

Slip Yoke Splines

NOTE: When you lubricate a slip yoke, the splined shaft can be either fully extended or fully collapsed.

After installation, add Meritor specification O-634-B, NLGI Grade 2 with EP additive to the slip yoke grease fitting. Six to eight pumps or approximately one oz (28 grams) is sufficient to lubricate the splines. Figure 6.17.

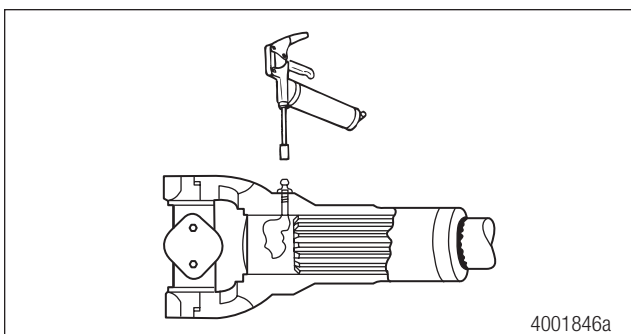

Figure 6.17

7 Wing-Style Permalube

Wing-Style Permalube

Hazard Alert Messages

Read and observe all hazard alert messages in this publication.

⚠ DANGER

Park the vehicle on a level surface. Block the wheels to prevent the vehicle from moving. Support the vehicle with safety stands. NEVER work under a vehicle supported only by jacks. Jacks can slip and fall over. Failure to use safety stands can result in death or serious personal injury and damage to components.

⚠ DANGER

Only service a driveline when the engine is OFF. A rotating driveline can cause serious personal injury and damage to components.

⚠ WARNING

NEVER use a steel hammer to seat bearing cups into yoke bores. A steel hammer can cause the yoke or bearing cup to crack and break off. Serious personal injury and damage to the trunnion, yoke or bearing cup can result.

⚠ WARNING

To prevent eye injury, always wear eye protection when performing vehicle maintenance or service.

Removal

Driveline

1. Park the vehicle on a level surface. Release the parking brake to allow the driveline to rotate freely. Block the wheels to keep the vehicle from moving. Raise the vehicle so that the area you will service is off the ground. Support the vehicle with safety stands.
2. Loosen and remove the four capscrews from the weld yoke end of the driveline. Support the weld yoke end, and separate it from the end yoke.
3. Loosen and remove the four capscrews from the slip yoke end of the driveline. Support the slip yoke end, and separate it from the vehicle.

Universal Joint

NOTE: Wing-style universal joints are permanently assembled. Welded steel straps attach the bearing cups to the trunnion to help ensure that the universal joint fits correctly into the mating yokes. Do not cut or remove the welded straps from the universal joint kits.

1. Loosen and remove the four capscrews retaining the universal joint cross to the weld yoke.
2. Loosen and remove the four capscrews retaining the universal joint cross to the slip yoke. Figure 7.1.

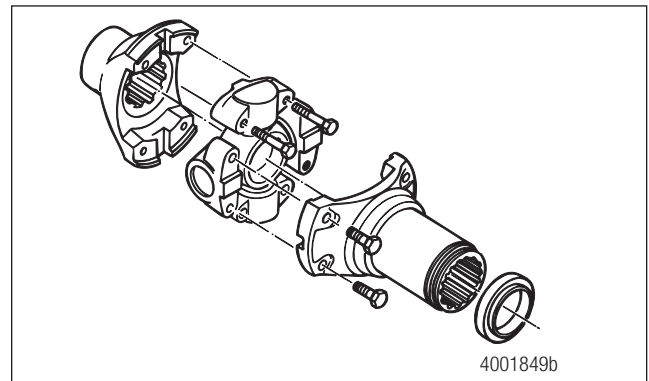

Figure 7.1

Installation

Universal Joint

1. Tap the bearing cups lightly with a brass or copper hammer to seat the bearing cups into the yoke pilot.

⚠ DANGER

Any time a universal joint is disconnected, new capscrews must be used during reassembly. Reusing old capscrews can cause the drive shaft to loosen or separate from the vehicle. Death or severe personal injury and damage to components can occur.

2. Install new capscrews and lock washers. Figure 7.2. Refer to Table C: Replacement Parts and Torque Specifications.

NOTE: Capscrews have a “lock patch” and can be hand-tightened only two or three threads.

3. Hand-tighten the capscrews to the yoke pilot.
4. Use a torque wrench to alternately tighten the capscrews to correct specifications. Figure 7.2. Refer to Table C: Replacement Parts and Torque Specifications.

7 Wing-Style Permalube

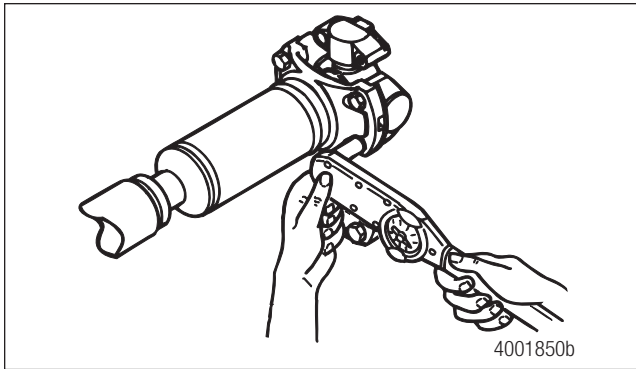

Figure 7.2

Table C: Replacement Parts and Torque Specifications

Drivelines	Name	Description	Torque Specs lb-ft (Nm)
Wing-Style Permalube	Capscrew	1/2-20 x 2-1/2"	115-135
		1/2-20 x 1-1/2"	(155-183)
		3/8-24	40-55 (54-74)
		7/16-20	63-83 (85-112)
	Jam Nut	1/2" H.D.	63-83 (85-112)

Driveline

NOTE: You may install either the slip yoke or weld yoke driveline end first when following the instructions below. After you install one driveline end, repeat these steps to install the opposite end of the driveline.

1. Support the driveline.
2. Tap the bearing cups lightly with a brass or copper hammer to seat the bearing cups into the end yoke.

NOTE: Any time a universal joint is disconnected, new capscrews must be used during reassembly.

3. Install the four new capscrews and lock washers that attach the universal cross to the end yoke. Figure 7.1.

NOTE: Capscrews have a "lock patch" and can be hand-tightened only two or three threads.

4. Hand-tighten the capscrews to the yoke pilot.
5. Use a torque wrench to alternately tighten the capscrews to Meritor's driveline torque specifications. Refer to Table C: Replacement Parts and Torque Specifications and Figure 7.2.
6. Repeat Step 1 to Step 5 to install the opposite driveline end.

Lubrication

Universal Joint

Wing-style universal joints can be greaseable or non-greaseable. Non-greaseable Permalube universal joints do not have grease fittings.

Wing-Style Permalube Universal Joints (Non-Greaseable)

Wing-Style Permalube universal joints are permanently lubricated with grease developed with specific wear and temperature properties. However, you must periodically lubricate the slip yoke splines. Refer to Table G and Slip Yoke Splines for specifications and maintenance procedures.

Wing-Style Universal Joints (Greaseable)

Wing-style greaseable universal joints have grease fittings and are not permanently lubricated. Refer to Table G: Torque Specifications. To lubricate greaseable universal joints, follow the procedures provided for the Full-Round driveline in Section 6.

Slip Yoke Splines

⚠ CAUTION

Do not remove the grease plugs from the cross in an attempt to add additional grease. Damage to the universal joint can result.

NOTE: When you lubricate a slip yoke, the splined shaft can be either fully extended or fully collapsed.

The slip yoke splines are not permanently lubricated and must be greased periodically.

Add Meritor specification O-634-B, NLGI Grade 2 with EP additive to the slip yoke grease fitting. Six to eight pumps or approximately one oz (28 grams) is sufficient to lube the splines. Figure 7.3.

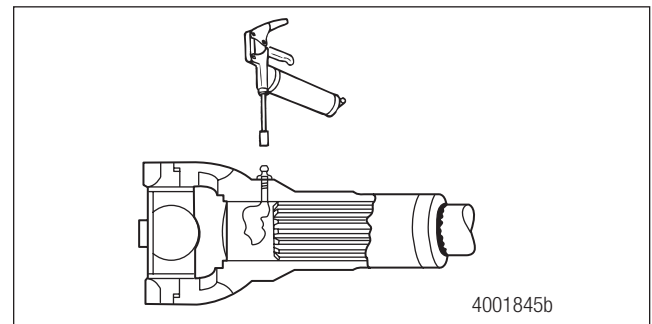

Figure 7.3

8 Easy Service

Easy Service

Hazard Alert Messages

Read and observe all hazard alert messages in this publication.

⚠ DANGER

Park the vehicle on a level surface. Block the wheels to prevent the vehicle from moving. Support the vehicle with safety stands. NEVER work under a vehicle supported only by jacks. Jacks can slip and fall over. Failure to use safety stands can result in death or serious personal injury and damage to components.

⚠ DANGER

Only service a driveline when the engine is OFF. A rotating driveline can cause serious personal injury and damage to components.

⚠ WARNING

To prevent eye injury, always wear eye protection when performing vehicle maintenance or service.

Removal

Driveline

1. Park the vehicle on a level surface. Release the parking brake to allow the driveline to rotate freely. Block the wheels to keep the vehicle from moving. Raise the vehicle so that the area you will service is off the ground. Support the vehicle with safety stands.
2. Loosen and remove the capscrews and bearing straps from the weld yoke end of the driveline. Support the weld yoke end and separate it from the end yoke.
3. Loosen and remove the capscrews and bearing straps from the slip yoke end of the driveline. Support the slip yoke end and separate it from the vehicle.

Universal Joint

1. Loosen and remove the capscrews from the two bearing cups on the weld yoke end of the driveline.
2. Remove the bearing cups. If necessary, use a bearing puller to remove the bearing cups from the yoke bores.
3. Work the trunnions free of the yoke bores. Remove the universal joint cross from the weld yoke.
4. Repeat Step 1 to Step 3 to remove the universal joint cross from the slip yoke.

Disassembly

Slip Yoke

1. Use a brass or copper hammer and a drift to tap the shroud off the slip seal.
2. Use a screwdriver to pry the seal out of the groove in the slip yoke. Figure 8.1.

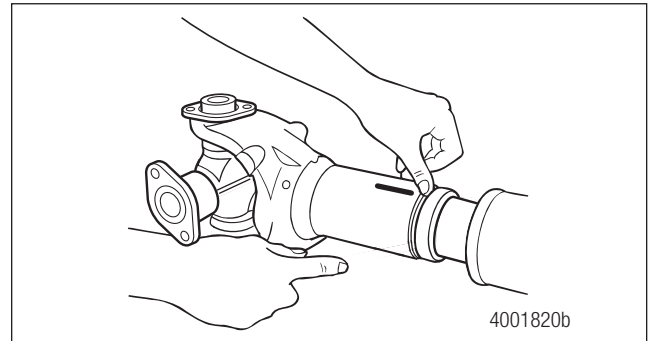

Figure 8.1

3. Mark the slip yoke and slip shaft sections to ensure that you reassemble them into their original positions. Figure 8.2.

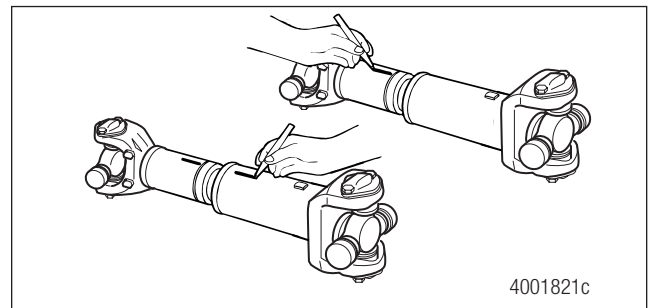

Figure 8.2

4. Pull the slip yoke and slip shaft sections apart. Figure 8.3.

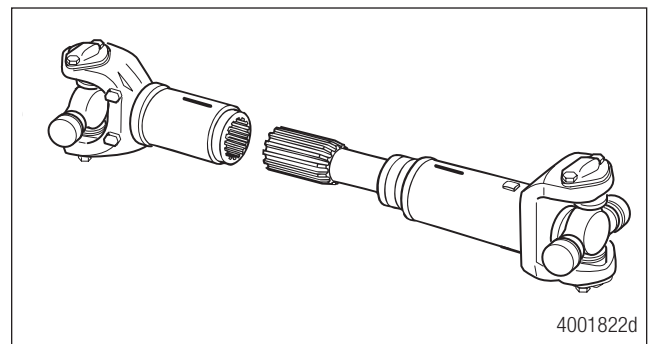

Figure 8.3

5. Remove the seal and shroud. Figure 8.4 and Figure 8.5.

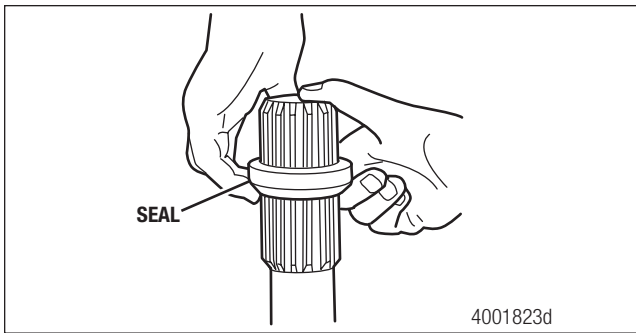

Figure 8.4

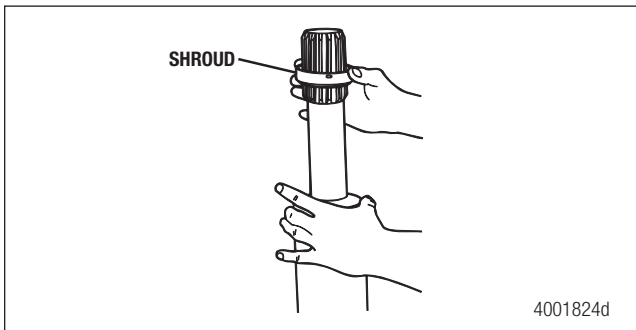

Figure 8.5

Assembly

Slip Yoke

1. Install the shroud onto the slip shaft. Figure 8.6.

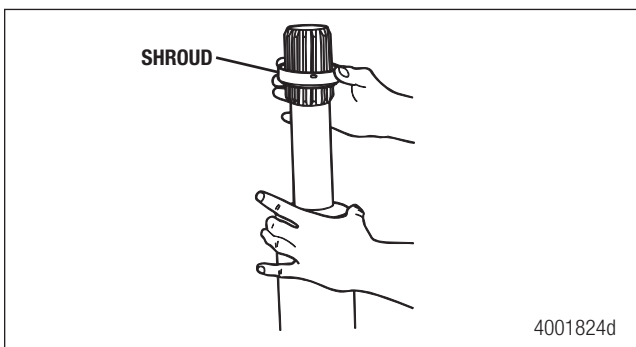

Figure 8.6

2. Install the new seal onto the spline shaft neck. Ensure that the small diameter side fits onto the splines first. Figure 8.7.

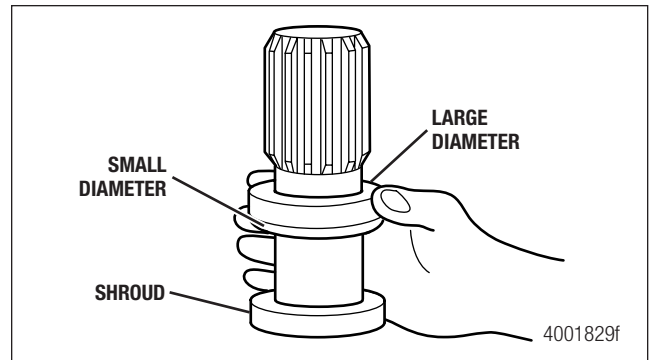

Figure 8.7

3. Install the slip shaft into the slip yoke. Ensure that you reassemble the sections into their original positions by using the marks made during disassembly. Figure 8.8.

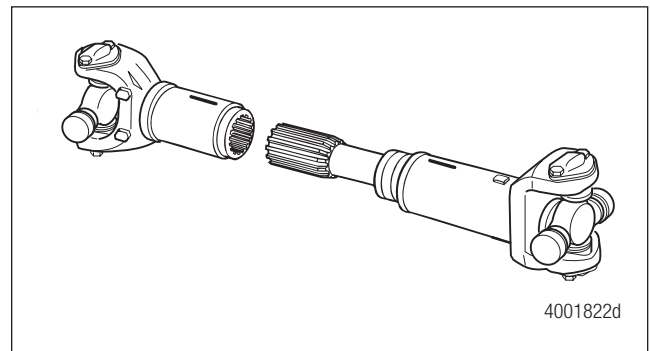

Figure 8.8

4. Install the seal onto the groove in the slip yoke. Figure 8.9.

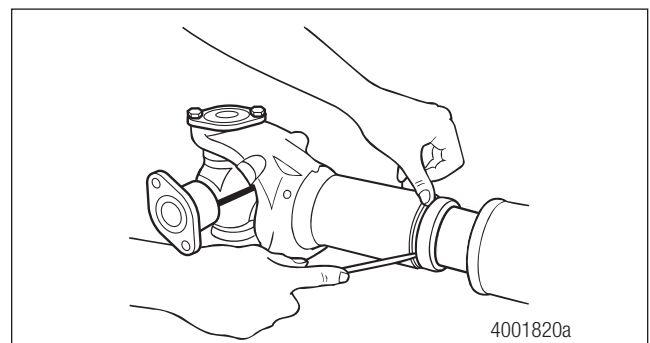

Figure 8.9

5. Snap the shroud over the seal.

8 Easy Service

Installation

Universal Joint

⚠ WARNING

Use a brass or synthetic mallet for assembly and disassembly procedures. NEVER hit steel parts with a steel hammer. Pieces of a part can break off. Serious personal injury and damage to components can result.

⚠ CAUTION

Do not seat the bearing cups into the yoke saddle by tightening down the bearing straps and capscrews. Uneven load distribution, yoke bearing rotation, and damage to the straps and yoke nibs can result.

NOTE: To help ensure maximum driveline performance, do not apply lubricant, grease, anti-seize compound, etc., to the yoke saddles.

1. Install the universal joint cross into the yoke. Always use new bolts and straps.

NOTE: For easier installation, do not remove the wire that fastens the bearing cups to the universal joint trunnion.

2. Install the bearing cups through the yoke bores and onto the universal joint cross trunnions.
3. Tap the bearing cup lightly with a leather or rubber mallet to seat the bearing cups into the yoke saddle.

NOTE: Capscrews have a “lock patch” and can be hand-tightened only two or three threads.

4. Hand-tighten the bearing capscrews. Use a torque wrench to tighten the capscrews to the specified torque. Refer to Table D: Torque Specifications – Easy Service.

Driveline

1. Wipe off the yoke saddle.

⚠ DANGER

Any time a universal joint is disconnected, new capscrews must be used during reassembly. Reusing old capscrews can cause the drive shaft to loosen or separate from the vehicle. Death or severe personal injury and damage to components can occur.

2. Support the driveline. Install the bearing straps and new capscrews onto the slip yoke end of the driveline.

NOTE: Capscrews have a “lock patch” and can be hand-tightened only two or three threads.

3. Hand-tighten the capscrews through the bearing strap into the yoke.
4. Use a torque wrench to alternately tighten the capscrews to Meritor’s driveline torque specification. Refer to Table D: Torque Specifications – Easy Service. Figure 8.10.
5. Repeat Step 1 through Step 3 to attach the weld yoke end of the driveline to the vehicle.

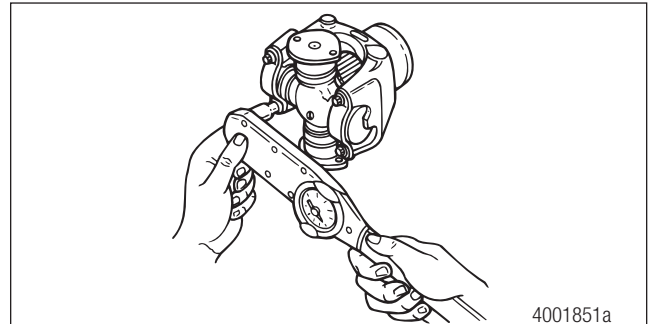
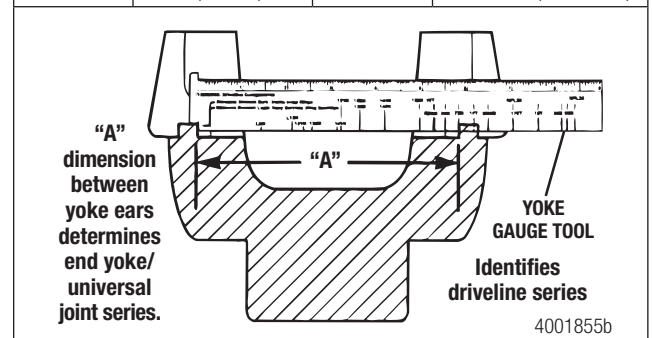

Figure 8.10

Table D: Torque Specifications – Easy Service

Driveline Series	"A" Inches (mm)	Thread Size Inches	Torque Specs lb-ft (Nm)
155T	4.97 (126.24)	3/8-24	40-60 (54-81)
16T	5.31 (134.87)	3/8-24	45-60 (61-81)
17T	6.19 (157.23)	1/2-20	115-135 (155-183)
176T	7.09 (180.08)	1/2-20	115-135 (155-183)
18T	7.63 (193.8)	1/2-20	115-135 (155-183)



Lubrication

Universal Joint

Lubricate the universal joints at the grease fitting until grease flows from the bearing cup seals on all four trunnions. Use a grease that meets Meritor specification O-634-B, NLGI Grade 2 with EP additive. Figure 8.11.

If grease does not purge from all four trunnion seals: Follow the steps below.

- Move the assembly UP-AND-DOWN or SIDE-TO-SIDE while you apply grease gun pressure. Figure 8.12.
- Loosen the bearing cup capscrews. Add grease until grease purges from the four seals.
- Tighten the bearing cup capscrews after grease purges.

If grease still does not purge from all four trunnion seals:

Remove the universal joint and correct the problem. If you cannot, replace the universal joint.

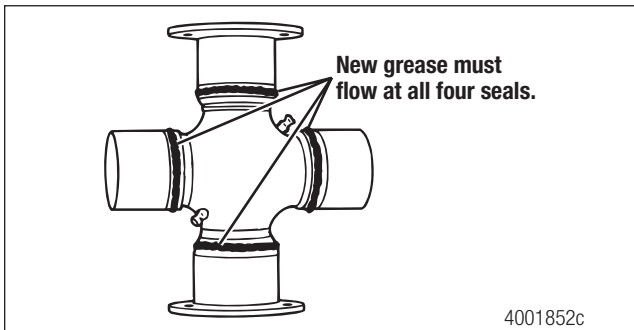

Figure 8.11

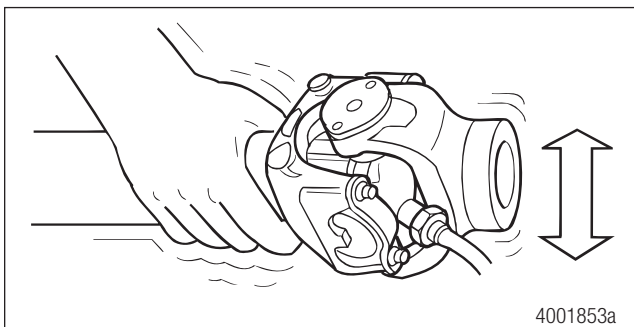

Figure 8.12

Slip Yoke Splines

NOTE: When you lubricate a slip yoke, the splined shaft can be either fully extended or fully collapsed.

Add a grease that meets Meritor specification O-634-B, NLGI Grade 2 with EP additive, to the slip yoke grease fitting. Six to eight pumps or approximately one oz (28 grams) is sufficient to lube the splines. Figure 8.13.

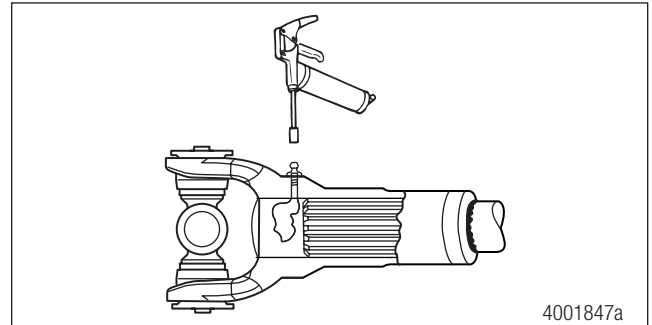

Figure 8.13

9 155R Series Slip Drive Shaft Assembly

155R Series Slip Drive Shaft Assembly

Hazard Alert Messages

Read and observe all hazard alert messages in this publication.

⚠ DANGER

Park the vehicle on a level surface. Block the wheels to prevent the vehicle from moving. Support the vehicle with safety stands. NEVER work under a vehicle supported only by jacks. Jacks can slip and fall over. Failure to use safety stands can result in death or serious personal injury and damage to components.

⚠ DANGER

Only service a driveline when the engine is OFF. A rotating driveline can cause serious personal injury and damage to components.

⚠ WARNING

To prevent eye injury, always wear eye protection when performing vehicle maintenance or service.

Removal

Driveline

1. Park the vehicle on a level surface. Release the parking brake to allow the driveline to rotate freely. Block the wheels to keep the vehicle from moving. Raise the vehicle so that the area you will service is off the ground. Support the vehicle with safety stands.
2. Loosen and remove the capscrews and bearing straps from the weld yoke end of the driveline. Support the weld yoke end and separate it from the end yoke.
3. Loosen and remove the capscrews and bearing straps from the slip yoke end of the driveline. Support the slip yoke end and separate it from the vehicle.

Universal Joint

Snap Ring Removal

NOTE: Refer to the Service Notes page on the front inside cover of this manual for information on how to obtain tools.

1. Use snap ring pliers to remove the snap rings. Figure 9.1.

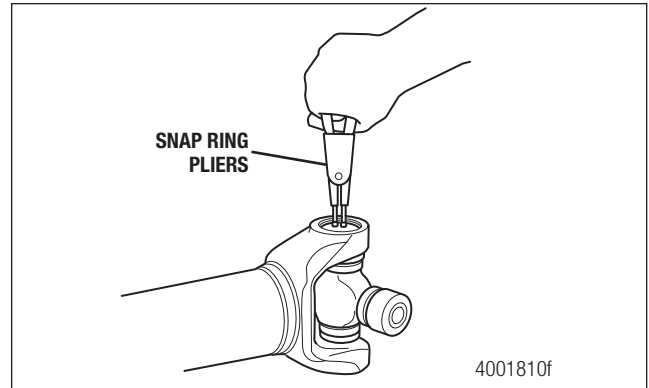

Figure 9.1

2. If necessary, use a brass drift and lightly tap the center of the bushing to assist in snap ring removal. Figure 9.2.

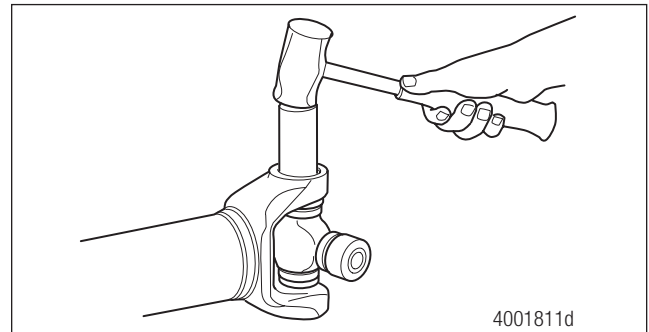

Figure 9.2

3. Repeat the previous steps on the other side of the yoke.

Round Bushing Removal Using a Press, Bridge and Bearing Cup Receiver

NOTE: Use only the appropriate tools to remove the round bushings. Do not use the SPX Kent-Moore yoke bearing cup installation tool (number J-44516) to remove the round bushings. Damage to the tool can result.

Use the following procedure to remove and install round bushings.

⚠ DANGER

Observe all warnings and cautions provided by the press manufacturer. Failure to do so can result in death or personal injury and damage to components.

1. Place the universal joint in a suitable press bridge and bearing cup bushing receiver. Figure 9.3.

9 155R Series Slip Drive Shaft Assembly

Disassembly

Standard Slip Configuration

1. Mark the slip yoke and slip shaft sections to ensure that you reassemble them into their original positions. Figure 9.6.

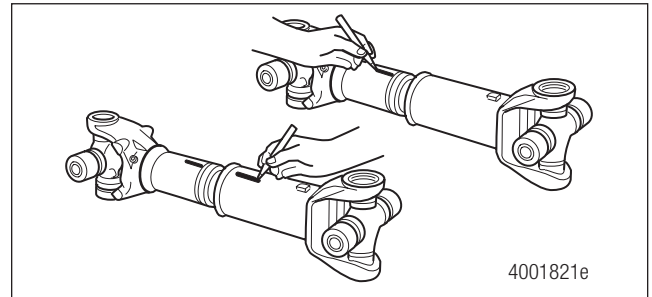

Figure 9.6

2. Pull the slip yoke and slip shaft sections apart. Figure 9.7.

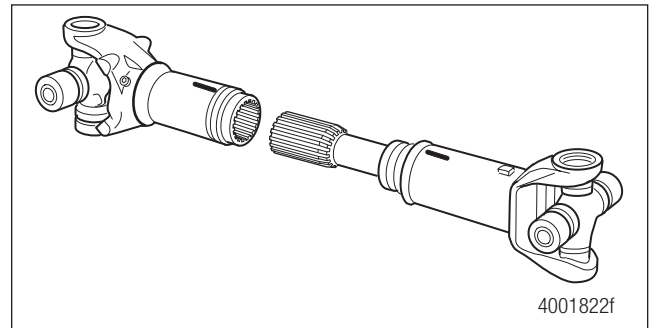

Figure 9.7

3. Remove the seal from the slip shaft. Figure 9.8.

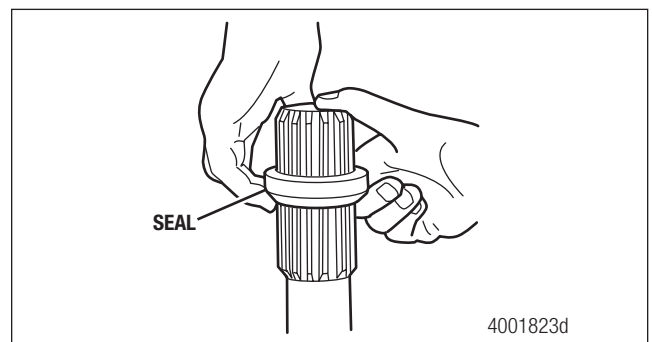

Figure 9.8

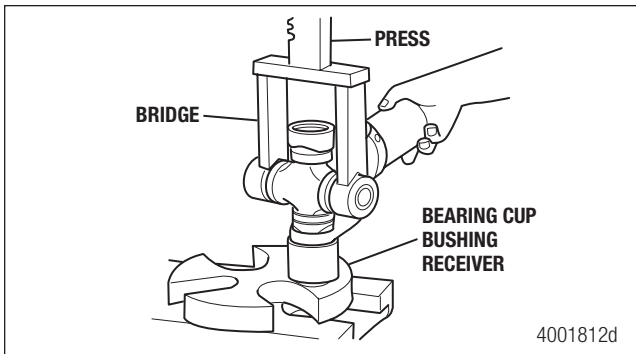

Figure 9.3

2. Press DOWN until the first round bushing loosens. Figure 9.3. Remove the round bushing. Figure 9.4.

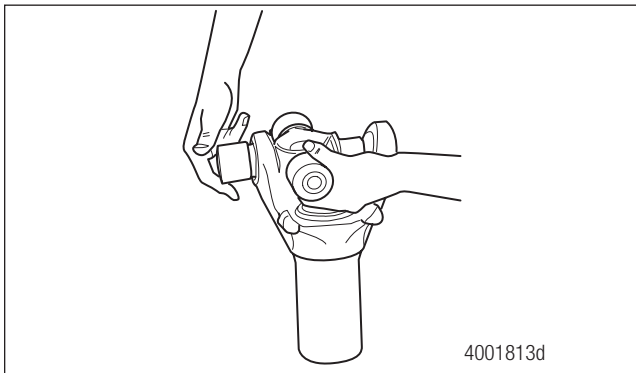

Figure 9.4

3. Rotate the shaft 180 degrees. Repeat the procedure for the opposite side of the universal joint. Figure 9.5.

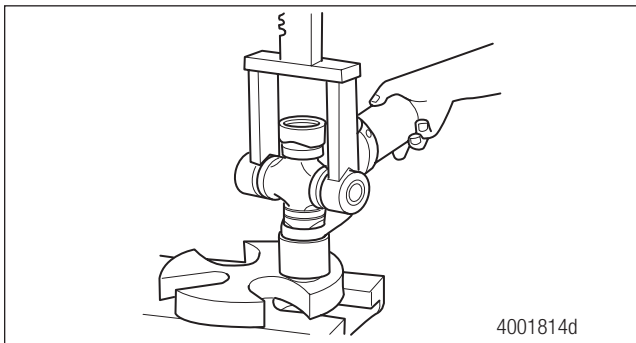

Figure 9.5

4. Remove the universal joint from the yoke.

9 155R Series Slip Drive Shaft Assembly

Assembly

Standard Slip Configuration

1. Remove the grease fittings from the slip yoke before you assemble the slip yoke and spline shaft sections.
2. Use the grease packet supplied with the slip yoke to apply the entire amount of grease into the slip yoke. Figure 9.9.

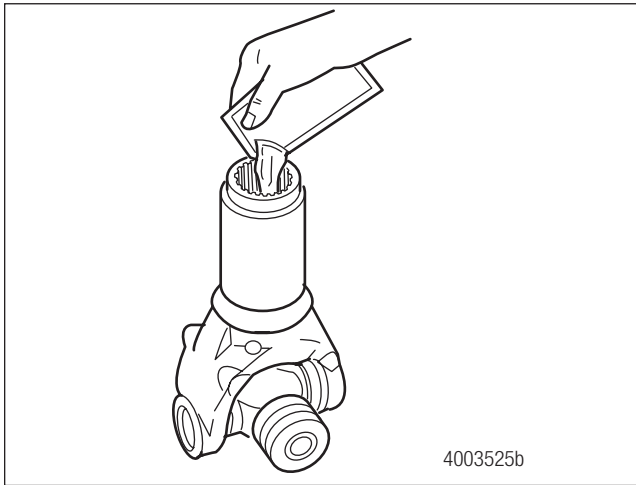

Figure 9.9

3. Use a brush to distribute lubricant on the splines. Figure 9.10.

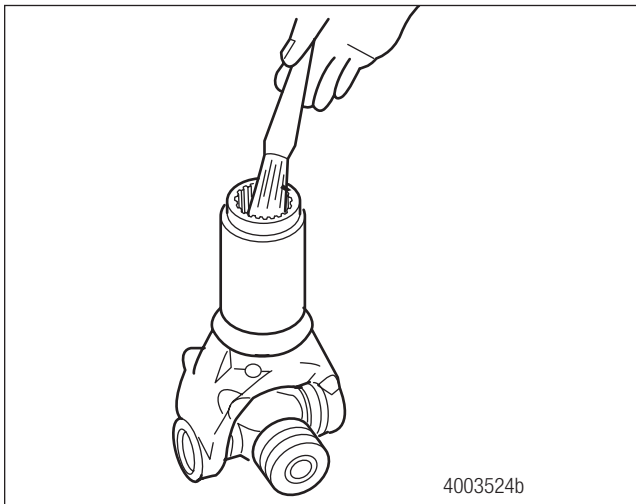

Figure 9.10

4. Install the new seal onto the spline shaft neck. Ensure that the small diameter side fits onto the splines first. Figure 9.11.

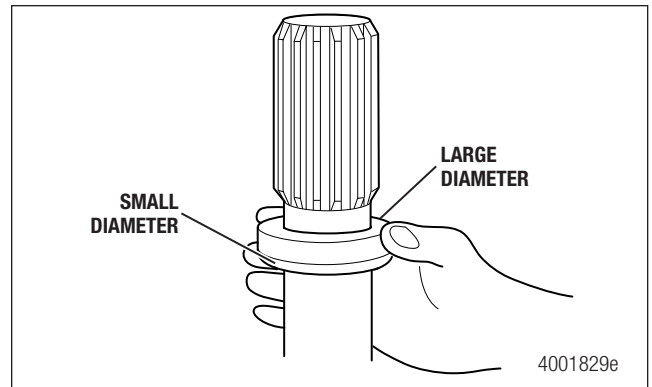

Figure 9.11

5. Align the slip yoke and spline shaft sections with the phasing marks you made on these sections during disassembly. Figure 9.12.

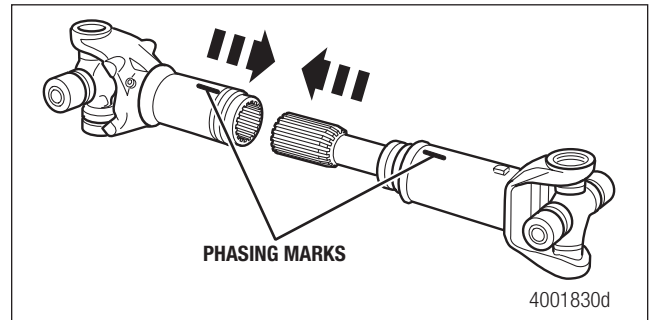

Figure 9.12

6. Install the spline shaft into the slip yoke until the splines fully engage. Figure 9.12.
7. Snap the seal into the groove. Figure 9.13.

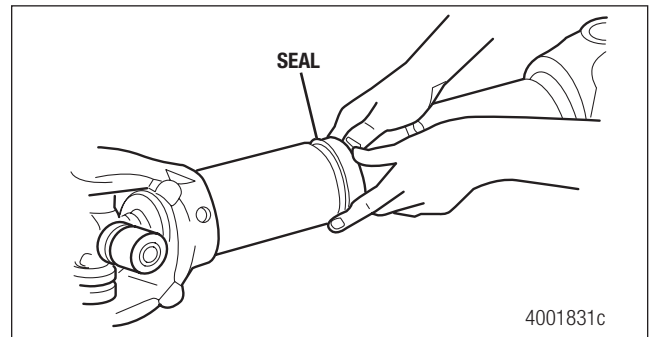

Figure 9.13

9 155R Series Slip Drive Shaft Assembly

8. Push together the driveline sections. Figure 9.14.

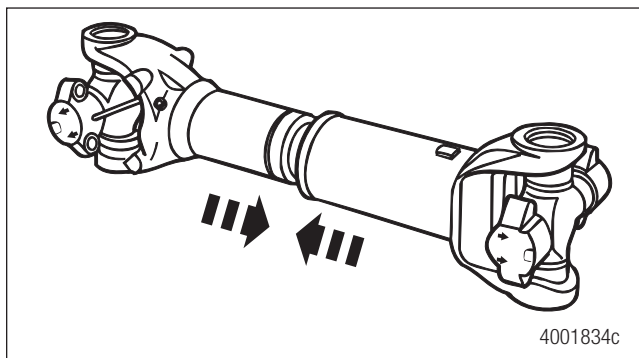

Figure 9.14

9. Reinstall the grease fittings.

Installation

Universal Joint

CAUTION

Do not use grease or anti-seize compound in the yoke ear bores. Damage to components can result.

1. Clean dirt and contamination from the slip yoke and weld yoke ear bores.

NOTE: The deflector is preassembled onto the bushing.

2. Position the first bushing onto the trunnion by threading the cross trunnion through the yoke bore. Figure 9.15.

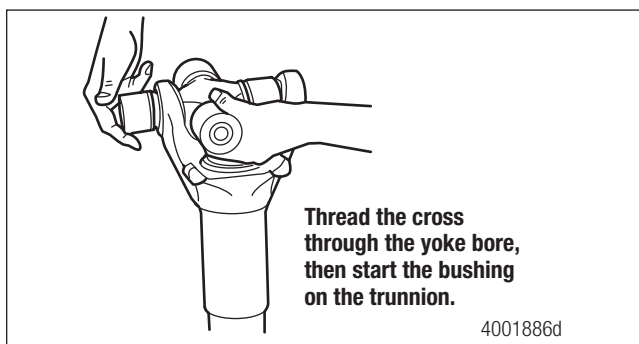

Figure 9.15

DANGER

Observe all warnings and cautions provided by the press manufacturer. Failure to do so can result in death or personal injury and damage to components.

CAUTION

Use an arbor press or universal joint press to install the round bushing into the yoke. Do not use a hammer, which can loosen and damage components.

3. Use an appropriate press to install the first bushing slightly past the snap ring groove. Figure 9.16.

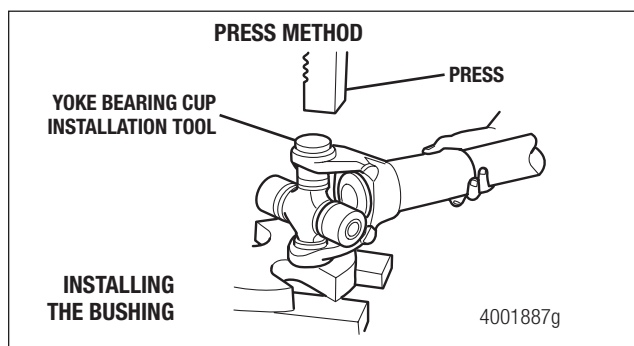

Figure 9.16

CAUTION

The snap ring must be fully seated into the snap ring groove to avoid damage to the driveline.

4. Use snap ring pliers to install the snap ring into the snap ring groove. Figure 9.17. Fully seat the snap ring.

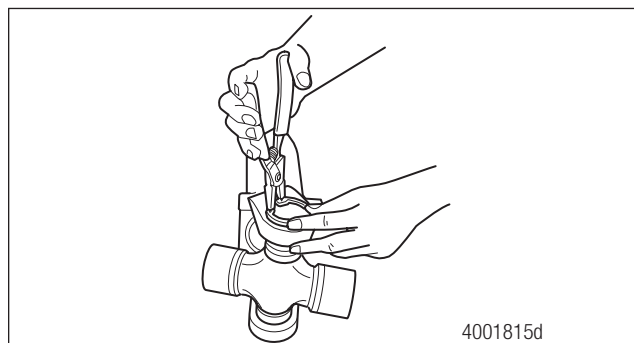

Figure 9.17

5. Position the second bushing onto the trunnion by threading the cross through the yoke bore as shown. Figure 9.18.

9 155R Series Slip Drive Shaft Assembly

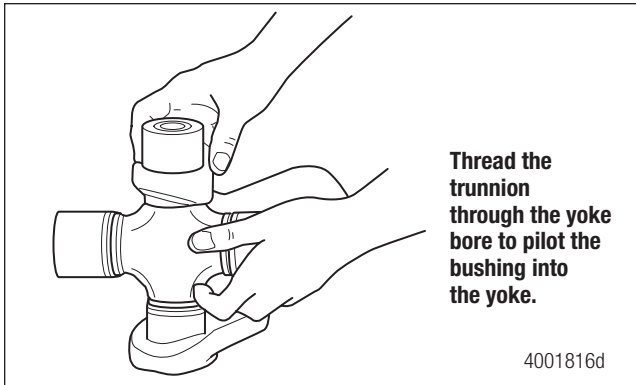

Figure 9.18

6. Use an appropriate press, yoke bearing cup installation tool or universal joint press to install the second bushing slightly past the snap ring groove. Check that the bushing is aligned with the universal joint. Figure 9.16.

CAUTION

The snap ring must be fully seated into the snap ring groove to avoid damage to the driveline.

7. Use snap ring pliers to install the second snap ring into the snap ring groove. Figure 9.19.

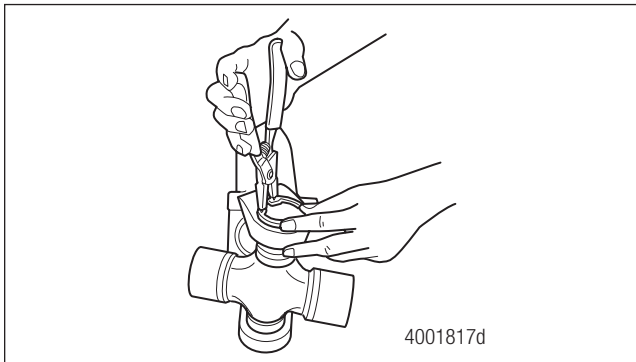

Figure 9.19

8. Strike the yoke ear with a brass or copper hammer to ensure that the universal joint moves freely. Figure 9.20.

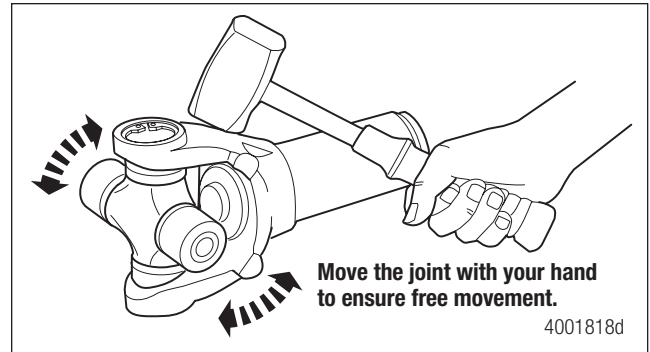

Figure 9.20

Driveline

1. Wipe off the yoke saddle.

DANGER

Any time a universal joint is disconnected, new capscrews must be used during reassembly. Reusing old capscrews can cause the drive shaft to loosen or separate from the vehicle. Death or severe personal injury and damage to components can occur.

2. Support the driveline. Install the bearing straps and new capscrews onto the slip yoke end of the driveline.

NOTE: Capscrews have a “lock patch” and can be hand-tightened only two or three threads.

3. Hand-tighten the capscrews through the bearing strap into the yoke.
4. Use a torque wrench to alternately tighten the capscrews to Meritor’s driveline torque specification. Figure 9.21.

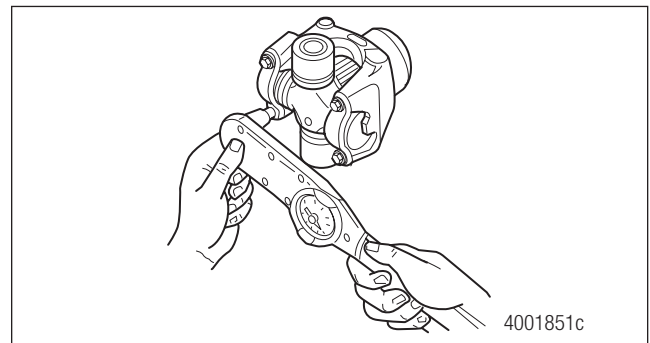

Figure 9.21

5. Repeat Step 1 to Step 3 to attach the weld yoke end of the driveline to the vehicle.

Lubrication

Universal Joint

Lubricate the universal joints at the grease fitting until grease flows from the bearing cup seals on all four trunnions. Use a grease that meets Meritor specification O-634-B, NLGI Grade 2 with EP additive. Figure 9.22.

If grease does not purge from all four trunnion seals: Follow the steps below.

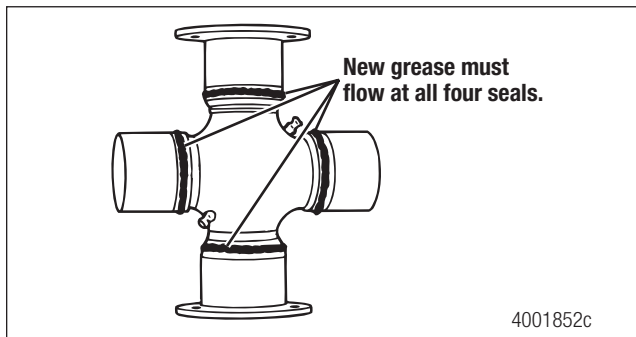

Figure 9.22

- Move the assembly UP-AND-DOWN or SIDE-TO-SIDE while you apply grease gun pressure.
- Loosen the bearing cup capscrews. Add grease until grease purges from the four seals.
- Tighten the bearing cup capscrews after grease purges.

If grease still does not purge from all four trunnion seals: Remove and replace the universal joint.

Slip Yoke Splines

Add a grease that meets Meritor specification O-634-B, NLGI Grade 2 with EP additive, to the slip yoke grease fittings. Six to eight pumps or approximately one oz (28 grams) is sufficient to lube the splines. Figure 9.23.

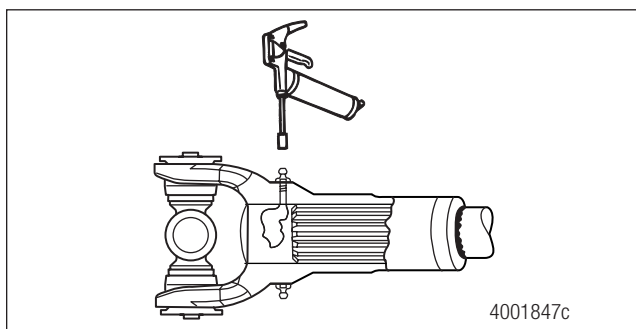

Figure 9.23

10 Center Bearing Removal and Installation

Center Bearing Removal and Installation

Hazard Alert Messages

Read and observe all hazard alert messages in this publication.

⚠ DANGER

Park the vehicle on a level surface. Block the wheels to prevent the vehicle from moving. Support the vehicle with safety stands. NEVER work under a vehicle supported only by jacks. Jacks can slip and fall over. Failure to use safety stands can result in death or serious personal injury and damage to components.

⚠ DANGER

Only service a driveline when the engine is OFF. A rotating driveline can cause serious personal injury and damage to components.

⚠ WARNING

To prevent eye injury, always wear eye protection when performing vehicle maintenance or service.

⚠ WARNING

NEVER use a steel hammer to seat bearing cups into yoke bores. A steel hammer can cause the yoke or bearing cup to crack and break off. Serious personal injury and damage to the trunnion, yoke or bearing cup can result.

⚠ WARNING

Only install the correct grade new bearing retainer bolts and stamped strap bolts. Do not reuse these parts. If the bearing retainer straps are damaged, install new retainers. Damaged and reused parts can affect driveline operation, which can cause the driveline to separate from the vehicle. Serious personal injury and damage to components can result.

⚠ WARNING

A driveline assembly can weigh more than 100 pounds (46 kilograms). Always use lifting devices and the correct procedures when handling drivelines to prevent serious personal injury and damage to components.

Center Bearings on Meritor Drivelines

The center bearing removal and installation procedures in this section apply to Meritor RPL Permalube, Wing-Style Permalube, Easy Service, Full-Round and 155R drivelines.

Self-Aligning Center Bearings

Most vehicles are equipped with self-aligning center bearings. Self-aligning center bearings do not use external deflectors. Some vocational applications, however, do use external deflectors. Both types of center bearings are shown in Figure 10.1.

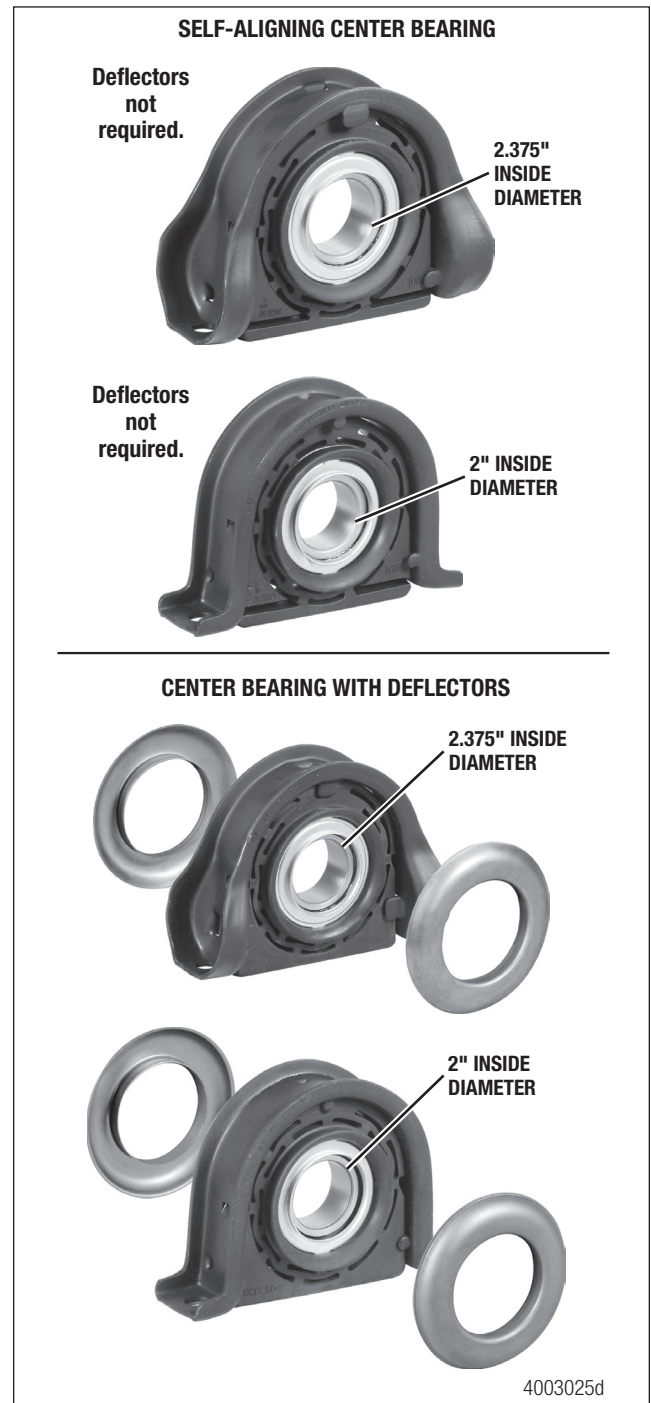

Figure 10.1

10 Center Bearing Removal and Installation

Center bearing designs use a small amount of external waterproofing grease. The external waterproofing grease can be displaced by centrifugal force, which can give the impression of leakage under normal conditions.

The actual bearing grease is contained within the assembly by seals.

A self-aligning center bearing accepts \pm five degrees of angular misalignment. This helps to ensure that the hanger bearing is correctly aligned to the driveline under all operating conditions. The cushion on the self-aligning center bearing is loose by design. The looseness allows the self-aligning movement.

Removal

Coupling Shaft

1. Ensure that the support strap is in the correct position to support the weight of the driveline.
2. Remove the center bearing bracket bolts. Figure 10.2 and Figure 10.3.

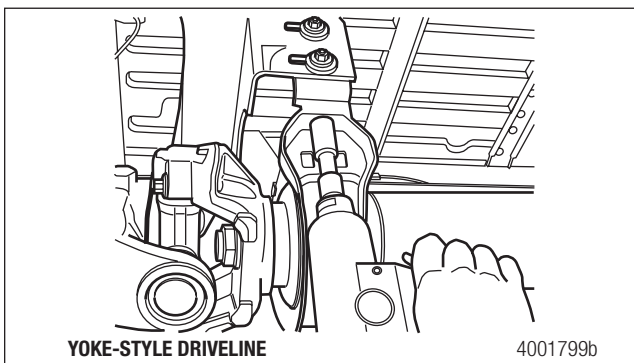

Figure 10.2

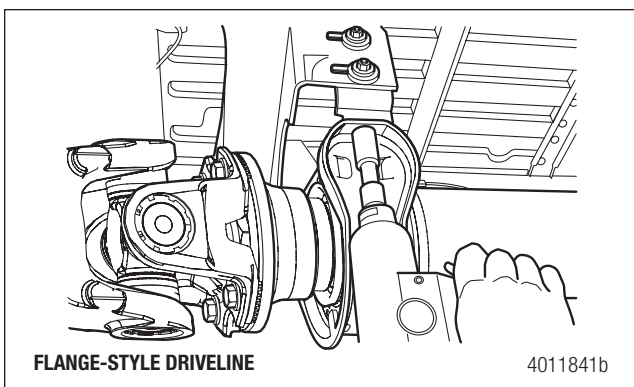

Figure 10.3

3. Remove the universal joint from the coupling yoke or flange. Discard the universal joint mounting bolts.

If it's necessary to unseat the bearing cup

assemblies: Use a rubber hammer to tap on the yoke or flange, or bearing cup. Once the coupling shaft is free, remove it from the support straps and move the driveline to a workbench.

For driveline assemblies with more than two coupling shafts:

Repeat Step 1 to Step 3 as necessary. Place the support straps on the additional coupling shafts.

Disassembly

Coupling Yoke or Flange

⚠ DANGER

Always replace a loose or damaged coupling yoke or flange. Only install a new coupling shaft yoke or flange nut. Do not reuse this part. A loose or damaged coupling yoke or flange, or a reused yoke or flange nut, can affect driveline performance and cause the driveline to separate from the vehicle. Death or serious personal injury and damage to components can result.

1. Remove the coupling shaft yoke or flange nut. Discard the nut. Inspect the washer. You can reuse the washer if it's not damaged. Figure 10.4 and Figure 10.5.

If the washer is damaged: Discard the washer and replace it with a new one.

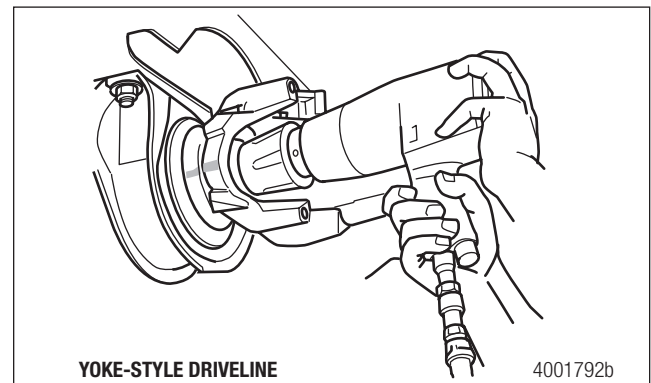

Figure 10.4

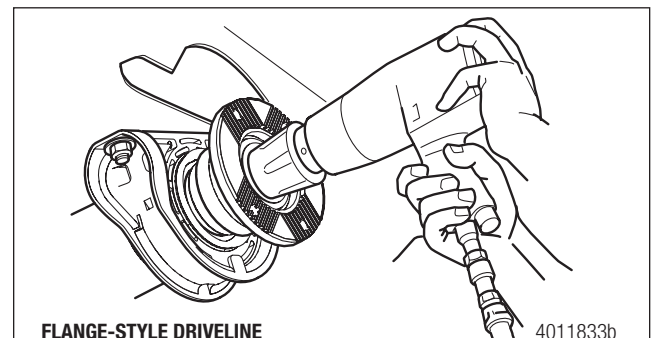

Figure 10.5

10 Center Bearing Removal and Installation

⚠ DANGER

Always reassemble a driveline according to the vehicle's original phasing type. A driveline that is not installed correctly can affect driveline performance and cause the driveline to separate from the vehicle. Death or serious personal injury and damage to components can result.

2. Mark the end yoke or flange counterbore to the coupling shaft "nose." This will help you to reassemble the center bearing end yoke or flange in its original phased position. Figure 10.6 and Figure 10.7.

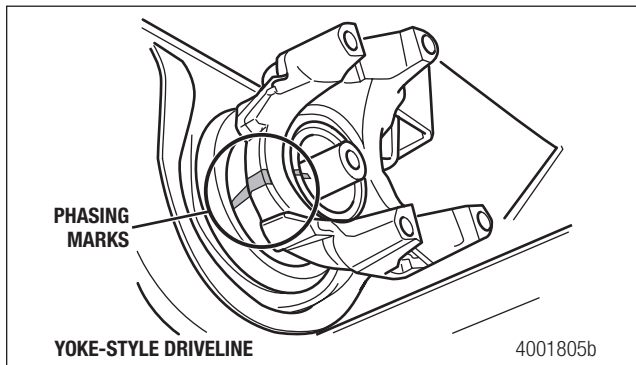

Figure 10.6

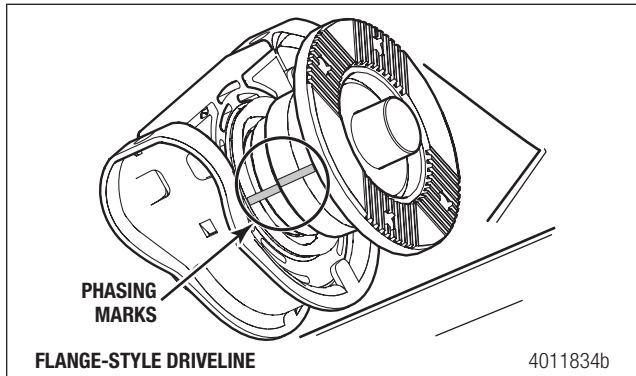

Figure 10.7

3. Remove the center bearing bracket bolts. Figure 10.8 and Figure 10.9.

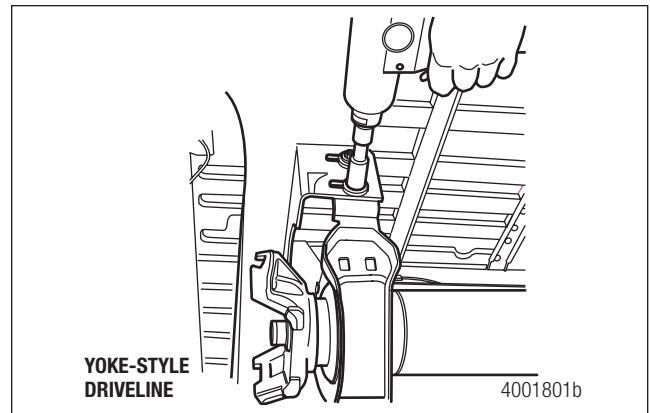

Figure 10.8

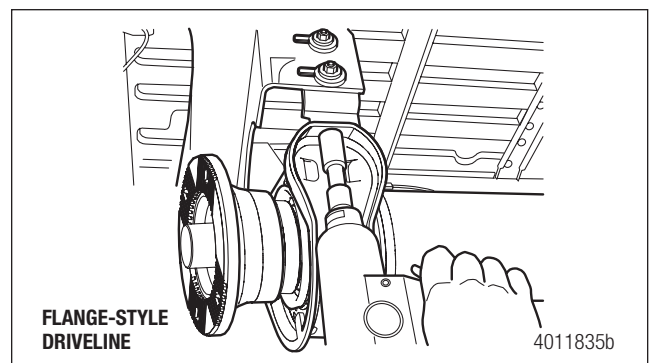

Figure 10.9

4. Remove the coupling shaft with the center bearing.

If it's necessary to unseat the cup assemblies: Use a rubber hammer to tap on the yoke or bearing cup. Once the coupling shaft is free, remove it from the support straps. Move the coupling shaft to a workbench area.

⚠ CAUTION

The center bearing end yoke or flange has a press fit. Use a puller tool to remove it from the driveline. Do not use a hammer. Damage to components can result.

5. Place the driveline on a workbench. Use a puller to remove the center bearing end yoke or flange. Do not use a hammer. Follow the puller tool manufacturer's instructions. Figure 10.10 and Figure 10.11.

If the yoke or flange is loose enough to remove by hand: Replace the entire coupling shaft.

10 Center Bearing Removal and Installation

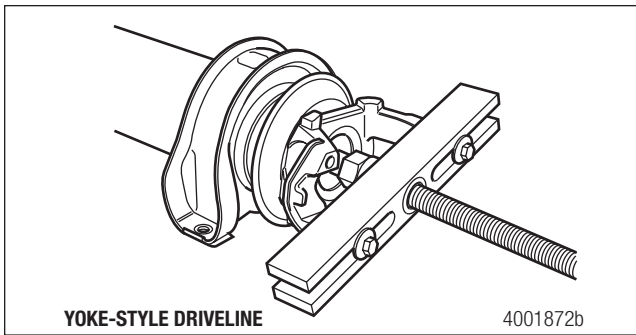

Figure 10.10

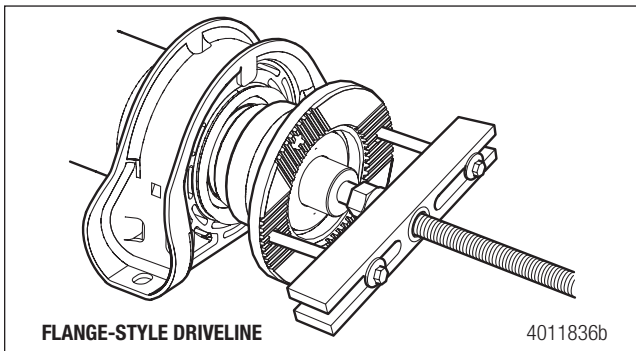

Figure 10.11

6. Inspect the center bearing end yoke or flange splines.

If the splines are damaged or missing, or the yoke or flange is cracked: Replace the yoke or flange.

7. Inspect the coupling shaft splines and threads.

If the splines or threads are damaged or missing: Replace the entire coupling shaft.

Center Bearing

1. Remove and discard the center bearing bracket. Figure Figure 10.12.

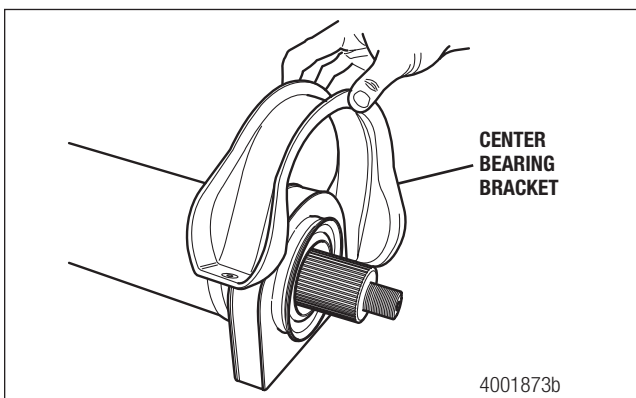

Figure 10.12

2. Remove and discard the rubber cushion. Figure 10.13.

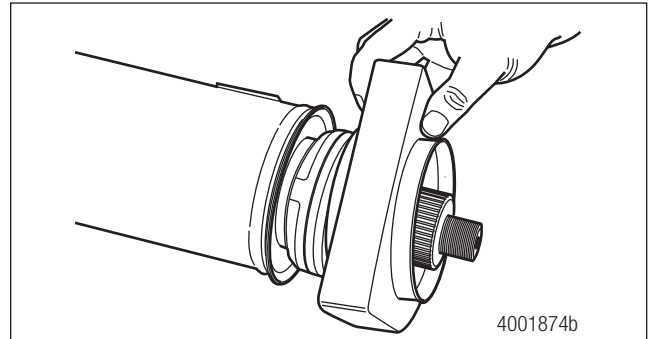

Figure 10.13

3. Use a puller to remove the bearing assembly from the coupling shaft. Follow the puller tool manufacturer's instructions. Discard the center bearing. Figure 10.14.

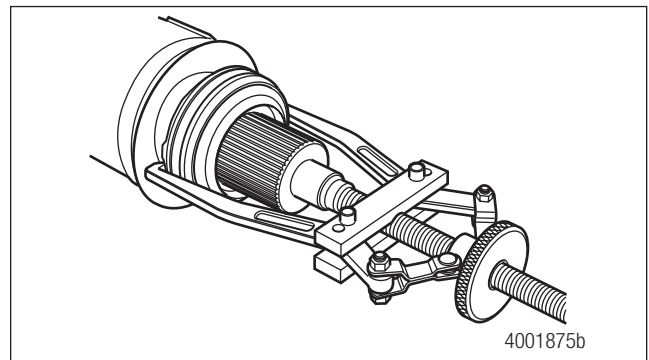

Figure 10.14

4. Inspect the coupling shaft for wear on the bearing diameter.

If the coupling shaft is damaged from a seized bearing: Replace the entire coupling shaft. Figure 10.15.

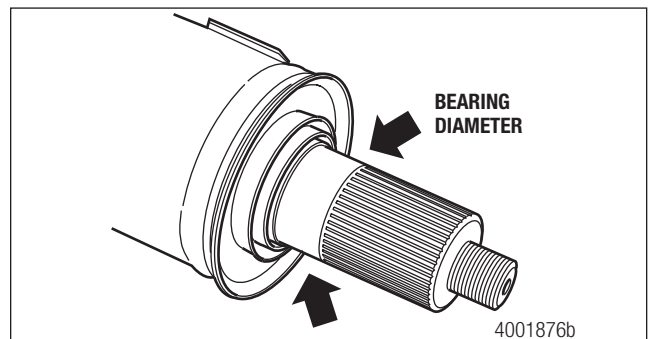

Figure 10.15

NOTE: Self-aligning center bearings do not require external deflectors.

5. Remove both deflectors, if equipped. Install a new center bearing, deflectors, if necessary, and coupling yoke.

10 Center Bearing Removal and Installation

Installation

Deflectors, If Required

NOTE: Self-aligning center bearings do not require external deflectors.

1. Wipe the center bearing support surface with a fine emery cloth.
2. Install a new deflector on the coupling shaft. To avoid damaging the deflector, use a section of tubing and a brass hammer to seat the deflector. Verify that the deflector is completely seated against the center bearing support shoulder. Figure 10.16.

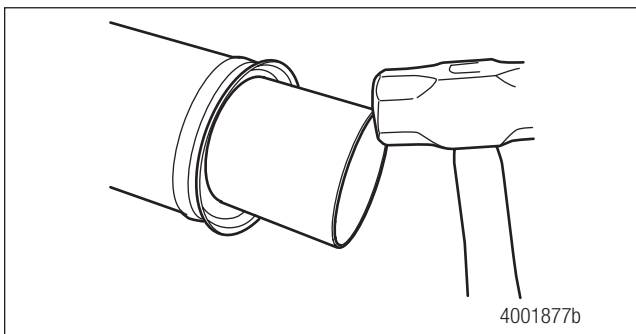

Figure 10.16

Center Bearing

NOTE: Self-aligning center bearings do not require external deflectors. Refer to [Technical Publication TP-2243, Center Bearing Inspection/Installation Guidelines](#) for center bearing inspection/installation guidelines.

1. Install deflectors, if included in the center bearing kit.
2. Carefully align the new center bearing assembly with the machined surface of the coupling shaft. Use your hands to push the center bearing onto the coupling shaft. Figure 10.17.

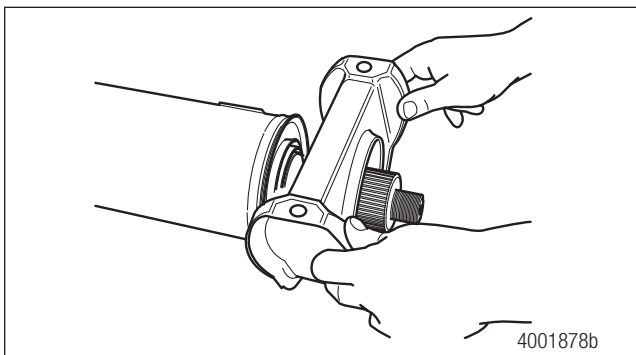

Figure 10.17

3. Use a punch and brass hammer to install the bearing.

4. If a deflector is required on the yoke or flange, use a section of tubing and a brass hammer to press the deflector onto the end yoke or flange. Use of the tubing will help avoid damage to the deflector. Figure 10.18 and Figure 10.19.

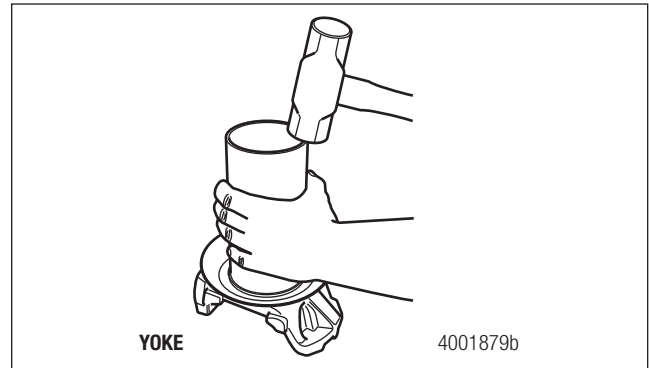

Figure 10.18

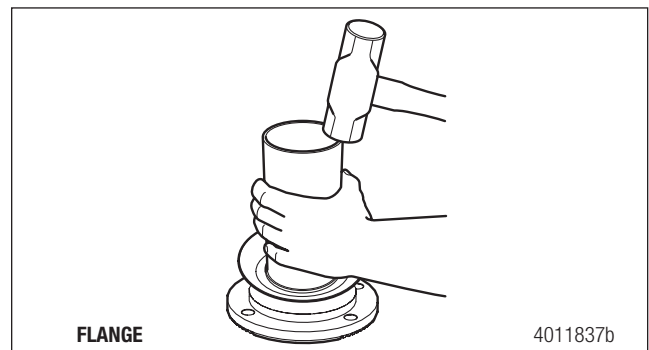

Figure 10.19

5. Use a rubber hammer to tap the yoke or flange onto the coupling shaft splines. The phasing marks on the driveline must be aligned. Figure 10.6 and Figure 10.7. Continue to tap the yoke or flange until it is completely seated against the center bearing. Do not use the nut to draw the yoke or flange down.
6. Install a washer and a new coupling shaft yoke or flange nut. Tighten the nut to 450-600 lb-ft (612-816 Nm).

Coupling Shaft

1. Verify that the support straps are in the correct position to support the weight of the driveline.
2. Align the center bearing bracket with the frame support.
3. Install bearing spacers, if necessary, to return the bearing bracket to its original position.
4. Install the center bearing bracket bolts. Tighten them to the vehicle manufacturer's specification. Figure 10.20 and Figure 10.21.

10 Center Bearing Removal and Installation

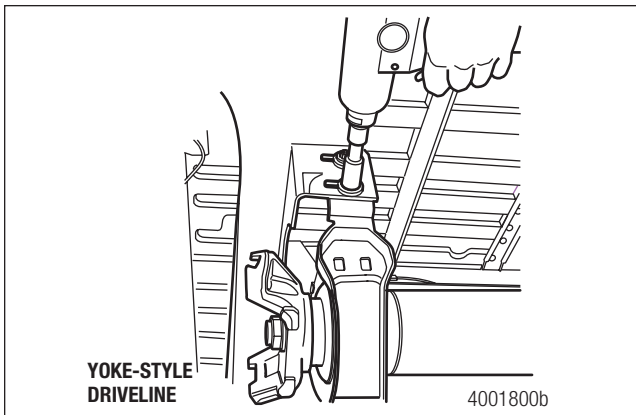

Figure 10.20

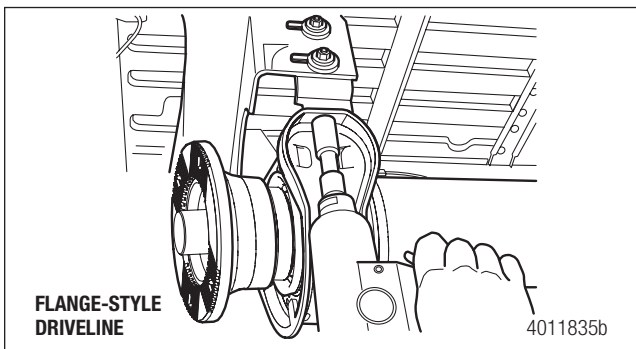

Figure 10.21

11 Lubrication

Lubrication

Hazard Alert Messages

Read and observe all hazard alert messages in this publication.

⚠ DANGER

Park the vehicle on a level surface. Block the wheels to prevent the vehicle from moving. Support the vehicle with safety stands. NEVER work under a vehicle supported only by jacks. Jacks can slip and fall over. Failure to use safety stands can result in death or serious personal injury and damage to components.

⚠ DANGER

Only service a driveline when the engine is OFF. A rotating driveline can cause serious personal injury and damage to components.

⚠ WARNING

To prevent eye injury, always wear eye protection when performing vehicle maintenance or service.

Maintenance

Greaseable Drivelines

The Full-Round, Easy Service, Wing-Style and 155R greaseable drivelines require periodic lubrication of the universal joints and slip yoke splines. Figure 11.1 and Figure 11.2.

If grease fittings require replacement, use only the correct type and size as specified in [PB-9895, Meritor Aftermarket Driveline Components](#). Using an incorrect grease fitting may prevent proper lubrication.

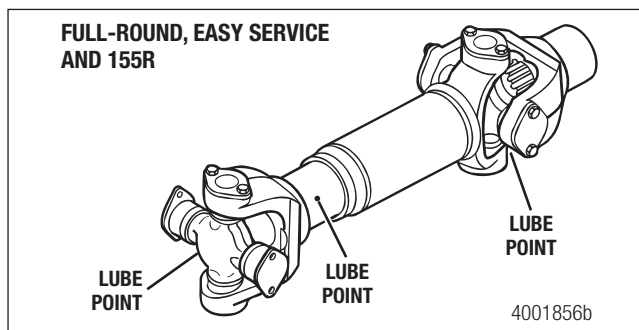

Figure 11.1

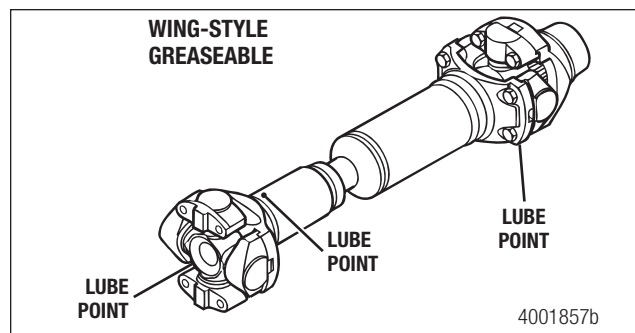

Figure 11.2

Non-Greaseable Drivelines

The RPL Series Permalube non-greaseable driveline is completely lubricated and sealed at the factory and does not require lubrication. Figure 11.3.

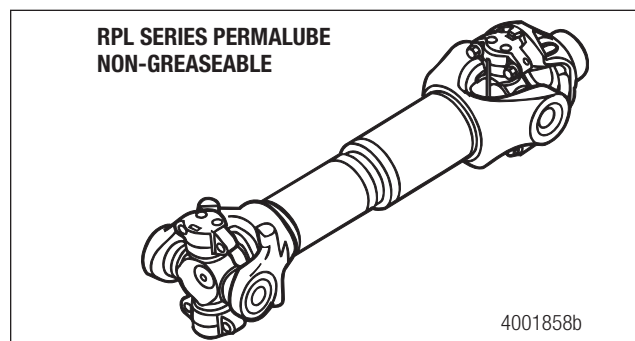

Figure 11.3

The Wing-Style Permalube non-greaseable driveline requires lubrication of the slip yoke splines ONLY. Figure 11.4.

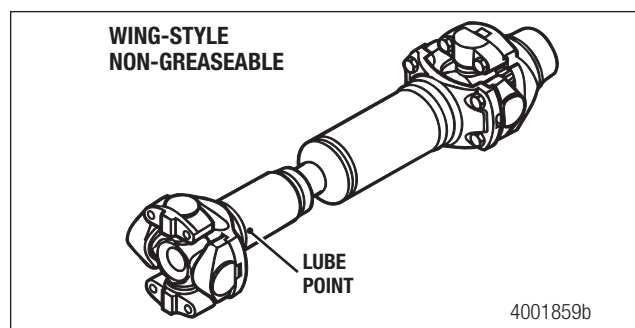

Figure 11.4

Driveline Inspection

- Inspect the Full-Round, Easy Service, Wing-Style and 155R greaseable drivelines for wear and damage at regularly scheduled maintenance intervals specified in Table E: Lubrication Intervals for Full-Round, Easy Service, Wing-Style and 155R Greaseable Drivelines.

- Inspect RPL Series Permalube and Wing-Style Permalube non-greaseable drivelines at least every 25,000 miles (40 000 km).

Table E: Lubrication Intervals for Full-Round, Easy Service, Wing-Style and 155R Greaseable Drivelines

Component	Application	Greasing Interval	Grease	Meritor Specification	NLGI Grade	Grease Description	Outside Temperature
Universal Joint, Slip Yoke and Splines	Line Haul — Applications where tractor is operated entirely on concrete or smooth paved road surfaces	50,000 miles (80 000 km)	Universal Joint Grease	0-634-B	2	Lithium 12-Hydroxy Stearate with Molybdenum Disulfide	Refer to the grease manufacturer's specifications for the temperature service limits.
	On Highway — Applications where tractor is operated at least 90% on paved road surfaces and up to 10% on gravel, dirt or unpaved roads	16,000 miles (25 000 km)					
	City — Applications where truck is operated at least 90% in city environment	6,500 miles (10 000 km)					
	Heavy Service — Moderate mileage operation (Less than 60,000 miles [96 560 km]) per year. On/off road vocations (10% or more off road). Moderate to frequent stops/starts (up to 10 stops per miles).	The greasing interval depends on the individual operating conditions, speed and loads. To determine the interval, inspect for the presence of grease at all positions until an interval can be determined. Grease the assembly as necessary.					

11 Lubrication

Table F: Approved Lubricants

Lubricant	Recommendation
Universal Joint Grease	Must meet Meritor Specification O-634-B
	Shell Gadus S1 V160D Grade 2
	Fuchs Renolit Molycent 2 NT
	Ford Material Specification ESA-M1C75-B

Torque Specifications

Driveline

Table G: Torque Specifications

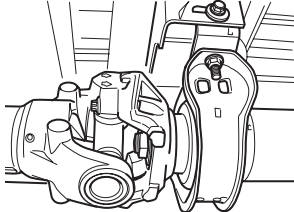
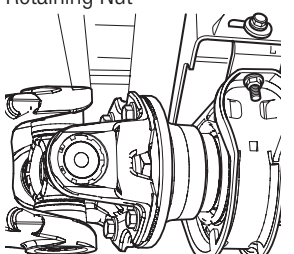
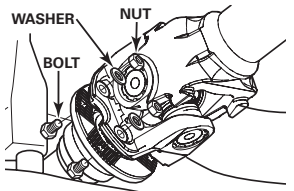
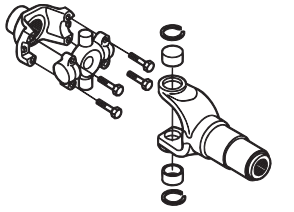
Description	Thread Size Inches	Torque Range lb-ft (Nm)
Coupling Shaft Yoke Retaining Nut 	1-1/4-18	450-600 (610-813)
Coupling Shaft Flange Retaining Nut 	M45 x 1.5	450-600 (610-813)
RPL35 and RPL35SD Series 180 MM Companion Flange Fasteners 	M14 x 2.0	133-163 (180-220)
RPL20, RPL25 and RPL25SD Series Permalube Capscrews 	1/2-20 M14 x 2.0	115-135 (155-183) 133-163 (180-220)

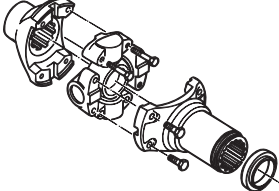
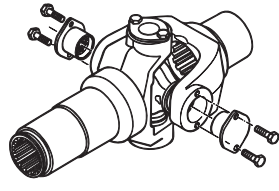
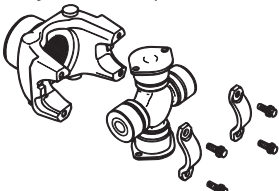
Description	Thread Size Inches	Torque Range lb-ft (Nm)
Wing-Style Permalube Capscrews 	1/2-20 3/8-24 7/16-20	115-135 (155-183) 40-55 (54-74) 63-83 (85-112)
Full-Round Capscrews 	5/16-24 3/8-24	26-35 (35-47) 38-48 (51-65)
Easy Service Capscrews 	3/8-24 ¹ 3/8-24 ² 1/2-20 ³	40-55 (54-75) 45-60 (61-81) 115-135 (155-183)

¹ RPL10 and RPL14 Series Permalube, and 155R Series Drivelines

² 16T Series Driveline

³ 17T, 17LT, 18T Series Drivelines

13 Troubleshooting

Troubleshooting

Special Tools

Electronic Vibration Analyzer (EVA) 2 Diagnostic Tool

The Electronic Vibration Analyzer (EVA) 2 is a diagnostic tool that helps detect low-frequency vibrations in a drivetrain. Axle ratio, number of cylinders, vehicle speed and engine rpm are factored into a calculation that determines vibration frequency, amplitude and the vehicle's system suspected of causing the vibration. Figure 13.1.

Use the EVA 2 diagnostic tool to determine the source of the vibration. Refer to the manufacturer's instructions for complete operating information for using this tool. The EVA 2 is available from SPX Kent-Moore. Refer to the Service Notes page on the front inside cover of this manual for ordering information.



Figure 13.1

Troubleshooting

Universal Joints

⚠ DANGER

Excessive looseness across the ends of the universal joint bearing cup assemblies can cause imbalance or vibration in the driveline assembly. Imbalance or vibration can cause component wear, which can result in separation of the driveline from the vehicle. Death or serious personal injury and damage to components can result.

Use the following procedure to check for looseness across the ends of the universal joint bearing cup assemblies and trunnions.

1. Hold the INBOARD yoke or flange on the driveline with both hands.
2. Try to move the yoke or flange UP-AND-DOWN and SIDE-TO-SIDE by applying at least 50 pounds (22.7 kg) of force to the driveline near the universal joints. Figure 13.2 and Figure 13.3.

If movement is greater than 0.006-inch (0.152 mm):
Replace the universal joint.

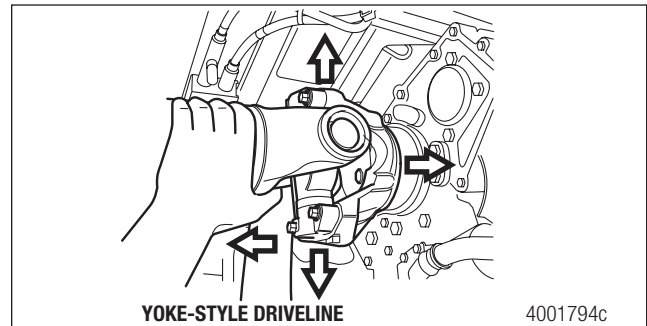

Figure 13.2

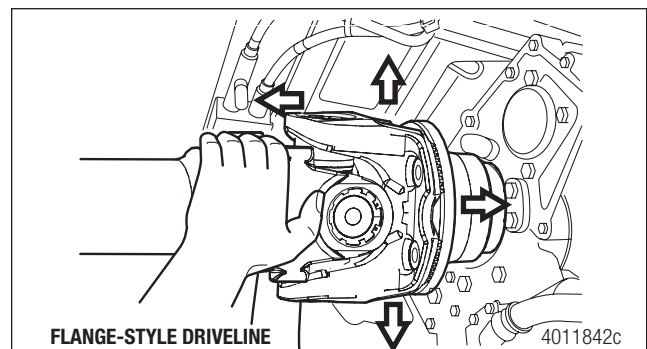

Figure 13.3

Greaseable Universal Joints

1. Check that all grease fittings are installed. Replace missing or damaged fittings with the correct type and size as specified in [PB-9895, Meritor Aftermarket Driveline Components](#). Tighten them to 6 lb-ft (8 Nm). Figure 13.4.

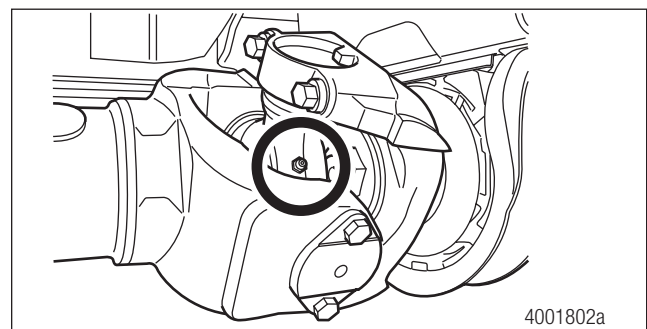

Figure 13.4

2. Check for loose grease fittings. Tighten them to 6 lb-ft (8 Nm).

Driveline Runout

1. Use a jack to raise the rear axle. Support the vehicle with safety stands.
2. Check each driveshaft for dents, bends, twists or other damage.
3. Use a dial indicator to measure that the driveshaft is straight within 0.030-inch (0.76 mm) on the tube 3-4-inches (76-102 mm) from the front and rear welds, and 0.030-inch (0.76 mm) at the center of the tube. Figure 13.5.

If the driveshaft is not within these specifications:

Disconnect the driveshaft at the location it exceeds 0.030-inch (0.76 mm). Rotate the driveshaft 180 degrees (detach universal joint from yoke and rotate shaft relative to yoke) and reattach. Check the runout again.

If the driveshaft is still not within the specification:

Remove the driveshaft and repair at a reputable driveline repair facility.

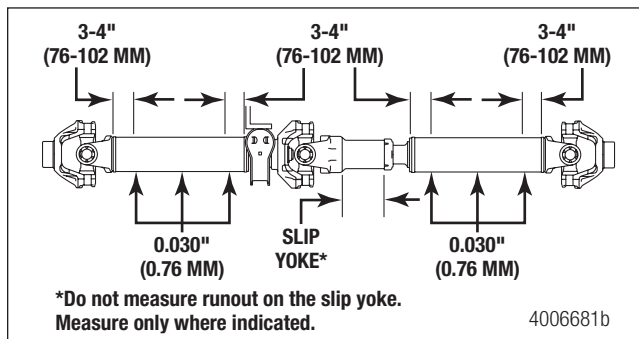

Figure 13.5

NOTE: Paint should be cleared off the tube if possible to get the best reading; uneven paint could cause error. Keep the dial indicator on a solid stable surface for better reading. Meritor recommends repainting after measurement.

Slip Yoke

NOTE: For single one-piece driveline systems, check the slip yoke for movement with the driveline installed and the vehicle on a level surface with its wheels on the ground. For multiple driveline systems, remove the slip yoke assembly from the vehicle to check for movement.

1. Ensure that the vehicle is on a level surface with its wheels on the ground. For single driveline systems, check the slip yoke for movement with the driveline installed. For multiple driveline systems, remove the slip yoke assembly from the vehicle and check for movement.
2. Firmly mount a dial indicator with a magnetic base onto the slip yoke barrel next to the dust seal. Figure 13.6. The dial indicator must not move when checking for slip yoke looseness or the measurement will not be correct.

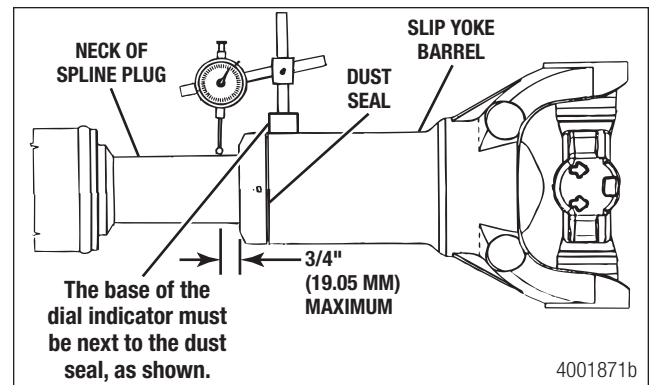

Figure 13.6

3. Extend the dial indicator arm from the base, so that it contacts the neck of the spline plug within 3/4-inch (19.05 mm) from the dust seal. Figure 13.6.
4. With hands near the center of the driveline, move the slip yoke UP-AND-DOWN. Check the dial indicator measurement. Movement between the spline plug and slip yoke must not exceed 0.017-inch (0.432 mm). Figure 13.7 and Figure 13.8.

If movement exceeds 0.017-inch (0.432 mm):

Components are worn or damaged. Replace as required.

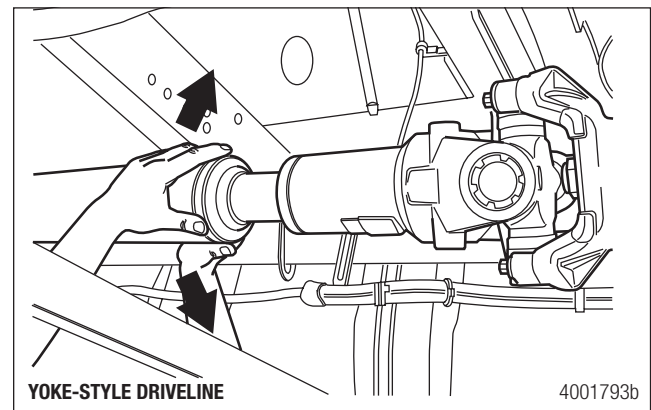

Figure 13.7

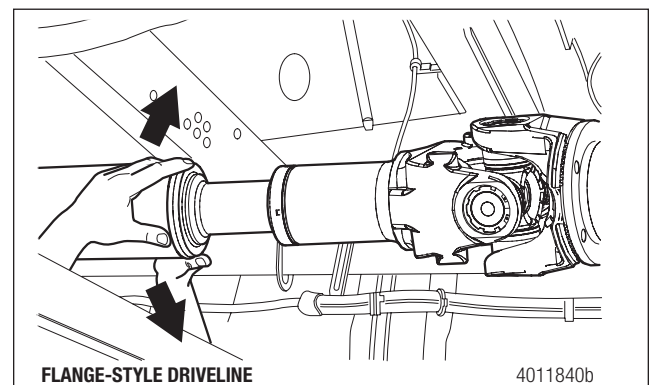

Figure 13.8

13 Troubleshooting

5. Use a dial indicator to examine the slip yoke spline for excessive radial movement. Radial movement between the slip yoke and the tube shaft must not exceed 0.017-inch (0.432 mm).

If the radial movement exceeds 0.017-inch (0.432 mm): Replace the slip yoke and the tube shaft.

6. Inspect the driveline for damage or bent tubing.

If the driveline is damaged or bent: Repair the driveline at a reputable driveline repair facility.

7. If necessary, carefully remove mud or road debris from the driveline.

8. Inspect the slip yoke spline seal for grease leakage or seal damage.

9. Inspect for missing balance weights, damaged tubing or a missing welch plug at the slip yoke.

For second order drivetrain vibration, refer to “Measure Driveline Angles” in Section 14.

Table H: Vibration

Condition	Cause	Correction
Driveline vibration	Driveline phasing incorrect	Correct the phasing by aligning the yokes on both ends of the driveline.
	Missing balance weights or foreign material on driveline tubing	Have the driveline balanced.
	Transmission or axle end yokes loose	Inspect for radial looseness. Tighten the nut or replace the end yoke.
	Excessive end play in universal joints	Replace the universal joints.
	Excessive hinging in slip section	Replace worn components.
	Welch plug loose or missing in slip yoke	Replace the welch plug or slip yoke.
	Worn center bearing	Replace the center bearing.
	Chassis ride height too low or too high	Readjust the ride height. Check and see if the ride height is to OEM specification.
	Torsional accelerations in driveline	Measure the transmission, driveline and axle planes. Record the readings and run the Driveline Analysis Program. If the angles are found to be out of specifications, adjust or replace components as directed.
	Loose, missing or damaged driveline fasteners or parts	Tighten loose fasteners, and replace damaged and missing parts.
	Loose or worn universal joint	Check and see if the snap rings are in place. Check for looseness or end play. Check for rust.
Component vibration	Use tools like EVA to check for vibration frequency. Unbalance occurs at 1st order or 1x driveshaft RPM. High or non-canceled angles occur at 2nd order or 2x driveshaft RPM.	

Condition	Cause	Correction
Low gear shudder at full drive or full coast under light load conditions	Incorrect phasing	The drive shaft should be checked to make sure that it is not out of phase on purpose.
	Driveline weight incompatible with engine-transmission mounting	Install a two-piece driveline with a shaft support bearing.
	Driveline too long for speed	Install a two-piece driveline with a shaft support bearing.
	Loose outside diameter fit on slip yoke spline	Change the slip yoke and spline plug.
	Universal joint loose	Inspect the universal joint for looseness; tighten to specification. Replace if necessary.
	Driveline out of balance or bent	Rebalance or replace.
	Worn universal joint	Replace the universal joint.
	Torsional or inertial excitation	Reduce the universal joint continuous running angle by adding shims to driveline components.

Table I: Premature Wear

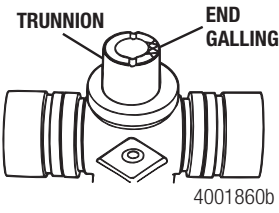
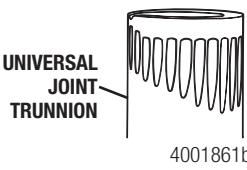
Condition	Cause	Correction
Low mileage universal joint wear	End yoke cross hole misalignment	Use an alignment bar to check for end yoke cross hole misalignment. Replace the end yoke if misaligned.
	Excess angularity	Check the universal joint operating angles. Reduce the angles if necessary.
	Incorrect or inadequate lubrication	Lubricate according to specifications (non-RPL designs).
	Worn or damaged seals	Replace the universal joint kit.
Repeat universal joint wear	Excessive continuous running load	Replace with a higher capacity universal joint and driveline.
	Continuous operation at high angle/high speed	Replace with a higher capacity universal joint and driveline. Check the universal joint operating angles. Reduce the angles if necessary.
	Worn or damaged seals	Replace the universal joint kit.
	Incorrect or inadequate lubrication	Lubricate according to specifications (non-RPL designs).
End galling of cross trunnion and bearing assembly 	Excessive angularity	Check the universal joint operating angles. Reduce the angles if necessary.
	Excessive torque load for universal joint and driveline size	Replace with a higher capacity universal joint and driveline.
	Incorrect or inadequate lubrication	Lubricate according to specifications (non-RPL designs).
Needle rollers brinelled into bearing cup and cross trunnion 	Excessive continuous running load	Replace with a higher capacity universal joint and driveline.
	Continuous operation at high angle/high speed	Replace with a higher capacity universal joint and driveline. Check the universal joint operating angles. Reduce the angles if necessary.
	Insufficient operating angles	Increase the operating angles to a minimum of two degrees.
	Normal bearing wear	Replace worn components.
	Incorrect or inadequate lubrication	Lubricate according to specifications (non-RPL designs).

13 Troubleshooting

Condition	Cause	Correction
Spalling of needles into trunnion	Incorrect or inadequate lubrication	Lubricate according to specifications (non-RPL designs).
	Dirt contamination	Replace worn components.
	Normal bearing wear	Replace worn components.
Broken cross and bearing assemblies TYPICAL SHOCK FAILURE — CROSS DAMAGE  4001862b	Excessive torque load for universal joint and driveline size	Replace with a higher capacity universal joint and driveline.

Table J: Slip Yoke Spline Wear

Condition	Cause	Correction
Seizure	Incorrect lubrication	Lubricate the slip yoke spline according to specifications. Check the seal.
	Worn or damaged part	Replace the spline components.
	Contamination	Lubricate the slip yoke spline according to specifications. Check the seal.
Galling	Worn or damaged parts	Replace the spline components.
	Contamination	Lubricate the slip yoke spline according to specifications. Check the seal.
Outside diameter wear at extremities	Incorrect lubrication	Lubricate the slip yoke spline according to specifications. Check the seal.
	Excessive loose outside diameter fit	Replace the spline components.
Spline shaft or tube broken in torsion	Tube size inadequate	Use a larger diameter tube.
	Excessive torque load for universal joints and driveline size	Replace with a higher capacity universal joint and driveline.
Spline shaft seal is dislodged	Shaft is too short	Make sure there is enough slip travel to accommodate full range of suspension travel. Consult with OEM if required.

Table K: Shaft and Tube

Condition	Cause	Correction
Shaft support bearing wear	Driveline too long for operating speeds	Install a two-piece driveline with a shaft support bearing.
	Incorrect lubrication of bearings	Replace the center bearing.
Shaft support rubber insulator wear  4001863b	Bending fatigue due to secondary couple loads	Reduce the universal joint continuous running angle.
	Excessive torque load for universal joint and driveline size	Replace with a higher capacity universal joint and driveline.
	Shaft support bearing misaligned; interferes with deflector	Realign the mounting bracket-to-frame crossmember to eliminate interference with the deflector.
	Radial play in excess of 0.200 inches (508 mm)	Mount the dial indicator with the base on the center bearing bracket and position the indicator tip against the shaft. Measure the total radial play by pushing up and pulling down on the driveline vertically. The total indicated reading (TIR) should not exceed 0.200 inches (508 mm). If the radial play is over 0.200 inches (508 mm), replace the center bearing assembly.
	Loose bolts; excessive wear	Refer to OEM for torque specifications.
Tube circle weld fracture	Balance weight located in apex of weld yoke lug area	Replace the tubing and rebalance.
	Balance weight too close to circle weld	Replace the tubing and rebalance.
	Incorrect circle weld	Replace the tubing and rebalance.
Shaft broken in bending	Driveline too long for operating speeds	Install a two-piece driveline with a shaft support bearing.
	Bending fatigue due to secondary couple loads	Reduce the universal joint continuous running angle.

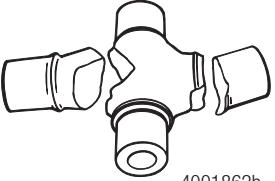
Table L: Yoke or Flange Fracture

Condition	Cause	Correction
Yoke broken or cracked  4001864a	Mating yoke lug interference at full jounce and rebound	Replace the yoke. Check the design for application. Use high angle yokes.
	Excessive torque load for universal joint and driveline size	Replace with a higher capacity universal joint and driveline.
	Bending fatigue due to secondary couple loads	Reduce the universal joint continuous running angles.

Table M: Universal Joint Center Parts

Condition	Cause	Correction
Cross or trunnion fracture	Abnormally high loading	Check for abuse of vehicle, stuck or overloading.
Bushing fracture	Excessive load for universal joint	Check for maximum driveline torque in lowest gear. If necessary, replace with a higher capacity universal joint and driveline.
	Excessive angularity	Check the universal joint operating angles. Reduce the angles if necessary.
	Worn or damaged parts	Replace with new parts.

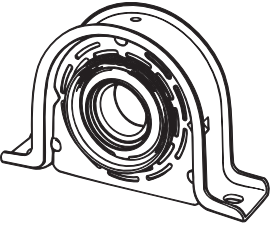
13 Troubleshooting

Table N: Yokes — Wing-Style Bushings

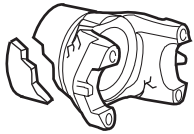
Condition	Cause	Correction
Loose bolts	Dirt or foreign material, such as paint, on mounting pad	Check for fretting on the mounting pads or drive tang. Surfaces must be free of foreign material and the bushings must be fully seated before bolts are fully tightened.
Broken bolts	Over or under torqued bolts If there is no fretting on the mounting pad or bolt hole and there is fretting on the drive tang: The bolt broke. If there is fretting on the mounting pad or bolt hole: The bolt was loose.	Surfaces must be free of foreign material and the bushings must be fully seated before bolts are fully tightened.
	Excessive angularity	

Table O: Yokes — Round Bushings

Condition	Cause	Correction
Extremely hard to remove or replace bushing	Distorted bushing hole in yoke or normally close clearances, fretting corrosion and rust build-up	When you remove a bushing, use a penetrating oil and be careful not to distort the ears on the yoke when you hammer on the center cross. Remove grease, rust and dirt from the mounting surfaces before assembly. Apply NeverSeez to make disassembly easier.
New center parts will not flex when you install them into the yoke	Yoke ears are distorted, causing the center parts to bind	Replace the yoke.

Measuring and Recording Driveline Angles

Special Tools

Tools You'll Need

- An inclinometer or a spirit level protractor to measure driveline angles. Figure 14.1 and Figure 14.2.

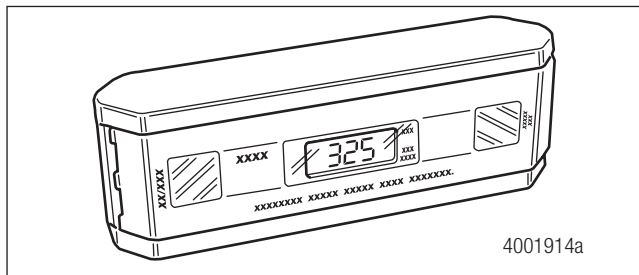

Figure 14.1

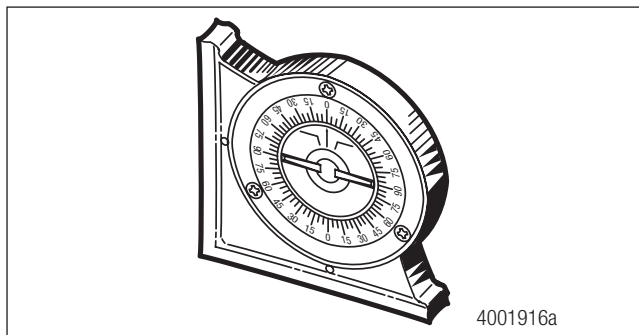

Figure 14.2

- A tape measure to measure ride height for air-ride-equipped tractors
- A Data Gathering Worksheet. Photocopy one of the several Data Gathering Worksheets provided at the end of this manual. You will use this photocopy to record the tractor's specifications and driveline angle measurements. Refer to the Service Notes page on the front inside cover of this manual for information on how to obtain additional Data Gathering Worksheets.

Overview

Prepare the Vehicle

⚠ DANGER

Park the vehicle on a level surface. Block the wheels to prevent the vehicle from moving. Support the vehicle with safety stands. NEVER work under a vehicle supported only by jacks. Jacks can slip and fall over. Failure to use safety stands can result in death or serious personal injury and damage to components.

⚠ WARNING

To prevent eye injury, always wear eye protection when performing vehicle maintenance or service.

1. Park the vehicle on a level surface. Do not engage the tractor brakes or the parking brakes.
2. Verify that all tires are on a level surface and inflated to the specified pressure.
3. Block the front tires at both the front and rear.

For Air-Ride-Equipped Tractors

1. Build air pressure to at least 115 psi (792.35 kPa).
2. Deflate air from the air bags: Use the dash-mounted deflate switch or release air pressure through the air valve at the rear of the tractor.
3. Allow the air bags to inflate completely.
4. Measure ride height with a tape measure. If necessary, adjust ride height to the correct vehicle manufacturer's specifications.

Data Gathering Worksheet

General Information Section

NOTE: Worksheets can be located at the end of this manual.

There are individual data gathering sheets for each of the following driveline configurations:

- One-piece driveline, single rear axle
- One-piece driveline, tandem rear axle
- Two-piece driveline, single rear axle
- Two-piece driveline, tandem rear axle

14 Measuring and Recording Driveline Angles

Select the correct worksheet for the vehicle's driveline configuration.

Fill in the general information section at the top right-hand corner of the data gathering worksheet. Figure 14.3.

Customer Name:	Robert Smith		
Phone:	(555) 555-1234	Fax:	(555) 555-6789
OEM:	XXXXX	Model:	XXXXXX
VIN: (Last 6 digits only)	XXXXXX	Unit:	XXXXX
Date:	1/1/99	DSM:	XXXXXX

Phasing Type (Refer to the reverse side.)	<input type="text"/>	Transmission Angle	<input type="text"/>	1st Driveline Angle	<input type="text"/>	2nd Driveline Angle	<input type="text"/>
Maximum Engine RPM	2200						
Transmission Top Gear Ratio	0.86:1						
Rear Suspension Ride Height	37"						
Maximum Engine HP	<input type="text"/>						

Usually found on the engine specification label attached to the tractor's engine block.

If equipped with air ride.

Usually found on the transmission specification plaque attached to the tractor instrument panel.

4001895b

Figure 14.3

Phasing Type Box

NOTE: The phasing type is not required for angle analysis of one-piece driveline configurations.

Fill in the "Phasing Type" box on the data gathering worksheet.

Refer to Phasing Type 1, 2, 3 and 4 examples listed on the worksheet. Figure 14.4.

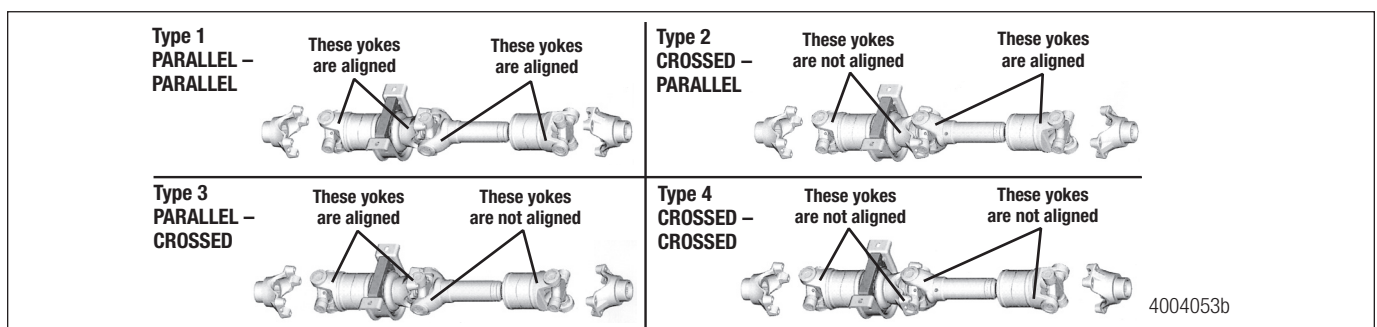

Figure 14.4

14 Measuring and Recording Driveline Angles

If you are unsure of the vehicle's phasing type, use "1" in the box. Figure 14.5.

Phasing Type (Refer to the reverse side.)	<input type="text" value="1"/>	
Maximum Engine RPM	<input type="text"/>	
Transmission Top Gear Ratio	<input type="text"/>	
Rear Suspension Ride Height	<input type="text"/>	
Maximum Engine HP	<input type="text"/>	
Clutch	<input type="text"/>	

4001904b

Figure 14.5

Positive (+) and Negative (-) Angle Designations

You must fill in driveline angle measurements on the Data Gathering Worksheet as POSITIVE (+) and NEGATIVE (-) dimensions.

Before you measure a component, go to the side of the vehicle and look at the driveline. If the FRONT of the component is HIGHER than the REAR of the component, the dimension will be POSITIVE (+).

If the FRONT of the component is LOWER than the REAR of the component, the dimension will be NEGATIVE (-). Figure 14.6.

Measure

Main Driveline Angles

Measure the Transmission Output Yoke Angle

Place the inclinometer or spirit level protractor on a spacer and on the transmission output yoke to measure the transmission output yoke angle. If a measurement is difficult to obtain on the yoke, you can measure from a flat transmission surface, including the countershaft bearing covers or the PTO cover. Figure 14.7 and Figure 14.8.

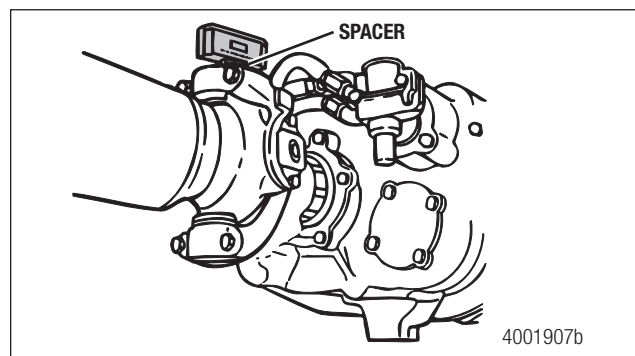

Figure 14.7

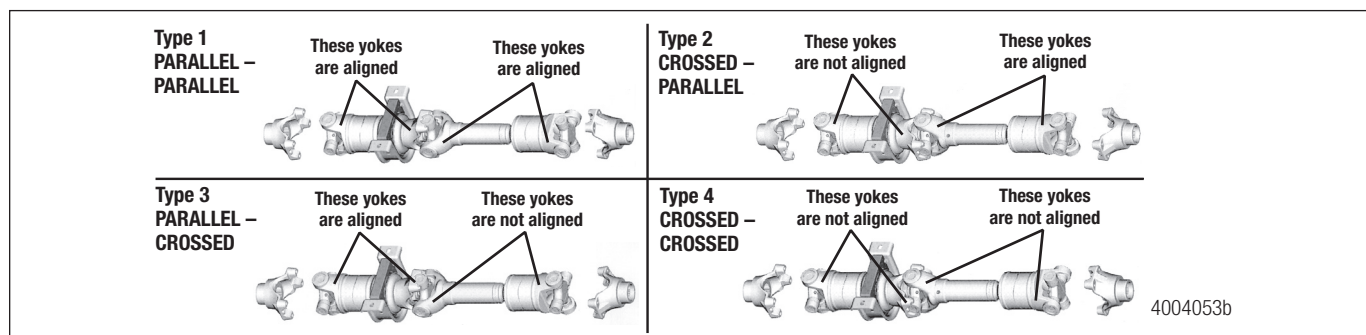

Figure 14.6

14 Measuring and Recording Driveline Angles

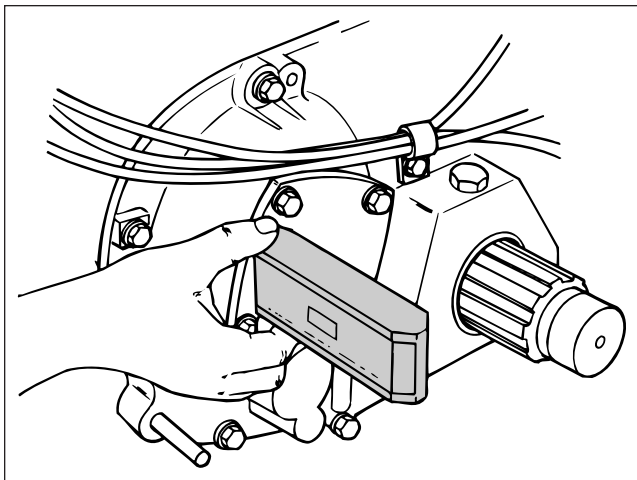

Figure 14.8

Record the measurement in the Transmission Angle box on the Data Gathering Worksheet. Figure 14.9.

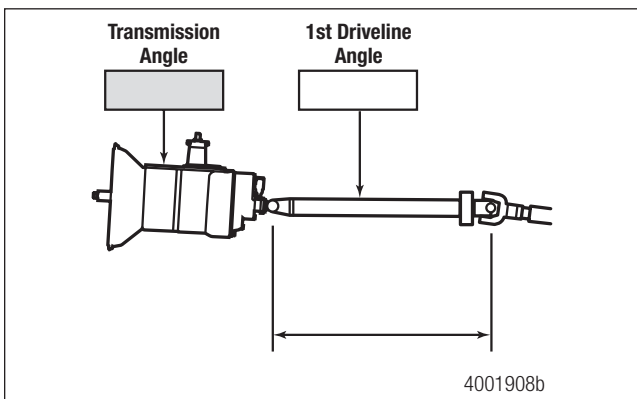

Figure 14.9

Measure the First and Second Driveline Angles

Place the inclinometer or spirit level protractor on a smooth, flat portion of the driveline tubing to measure the first and second driveline angles. Figure 14.10. **Do not measure over welds or balance weights. The measurements will not be valid.**

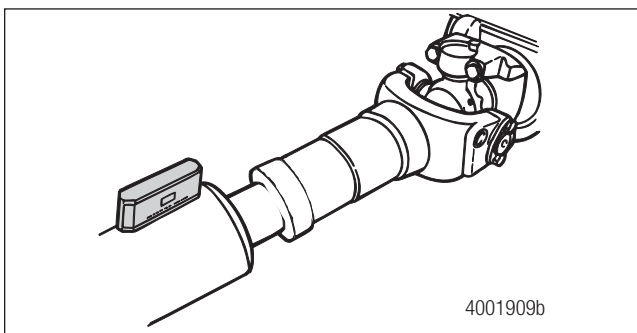

Figure 14.10

Record the measurements in the First Driveline Angle and Second Driveline Angle boxes on the Data Gathering Worksheet. Figure 14.11.

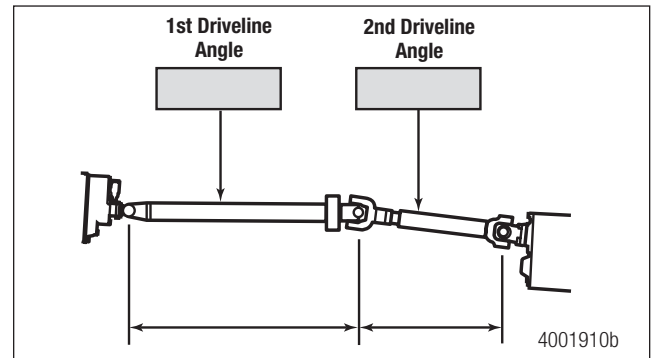

Figure 14.11

Measure the Forward Rear Drive Axle Angle

Place the inclinometer or spirit level protractor on a spacer and on the output yoke or on a smooth, flat portion of the axle housing tube (the "long" side, away from the bowl and near the suspension U-bolt) to measure the forward rear drive axle angle. Figure 14.12 and Figure 14.13.

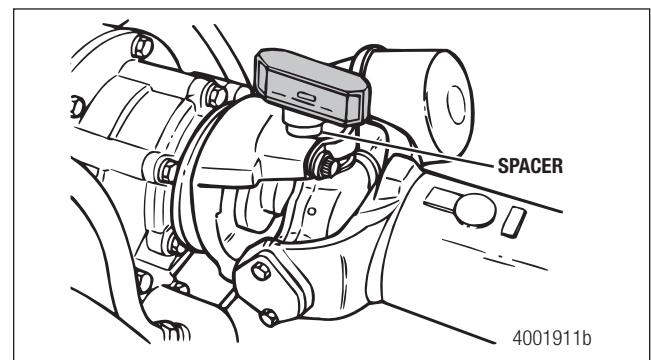

Figure 14.12

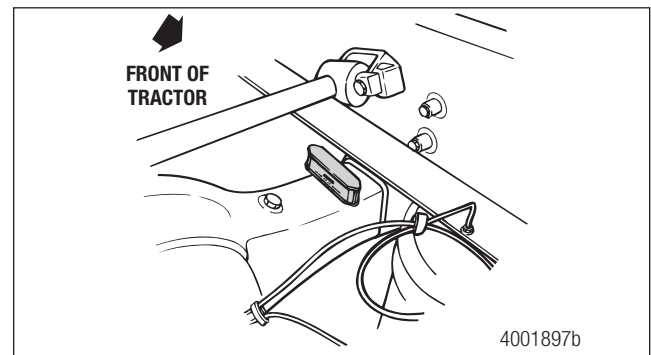

Figure 14.13

NOTE: Figure 14.13 is the preferred measurement method.

14 Measuring and Recording Driveline Angles

Write the measurement in the Front Axle Angle box on the Data Gathering Worksheet. Figure 14.14.

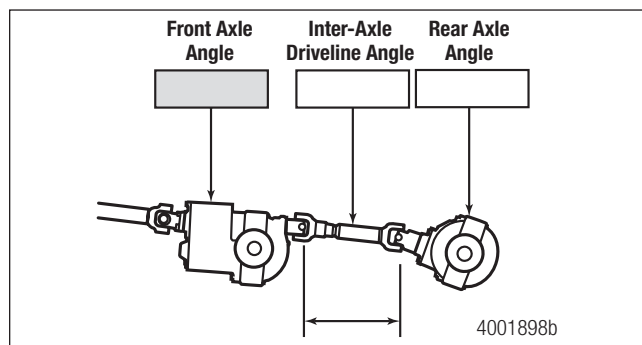

Figure 14.14

Measure the Inter-Axle Angle

Place the inclinometer or spirit level protractor on a smooth, flat portion of the driveline tubing to measure the inter-axle angle. Figure 14.15. **Do not measure over welds or balance weights. The measurement will not be valid.**

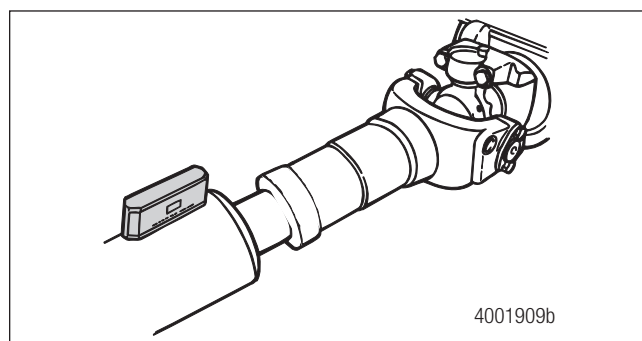

Figure 14.15

If the driveline tubing is too short, place the edge of the inclinometer or spirit level protractor vertically on the tube. Subtract 90 degrees from the reading to determine the correct angle. Figure 14.16.

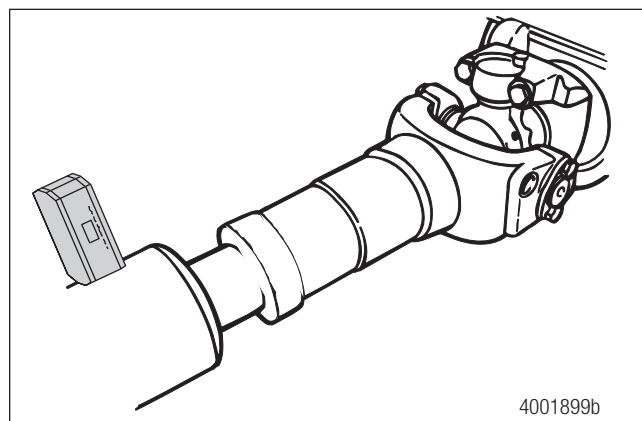

Figure 14.16

Write your measurement in the Inter-Axle Angle box on the Data Gathering Worksheet. Figure 14.17.

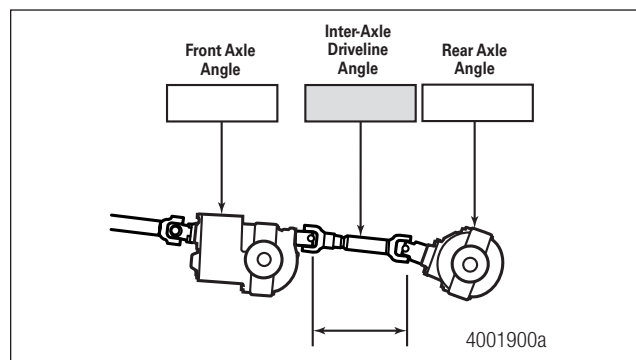

Figure 14.17

Measure the Rear Axle Angle

Place the inclinometer or spirit level protractor on a spacer and on the input yoke or on a smooth, flat portion of the axle tube (the "long" side, away from the bowl and near the suspension U-bolt) to measure the rear axle angle. Figure 14.18 and Figure 14.19.

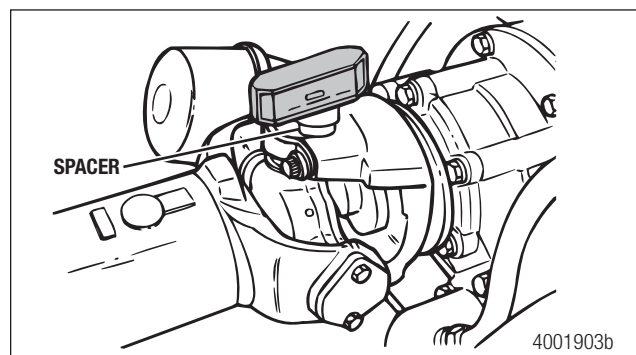

Figure 14.18

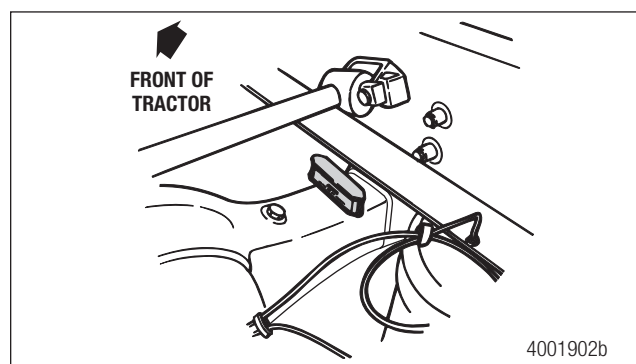

Figure 14.19

NOTE: Figure 14.19 is the preferred measurement method.

Write the measurement in the Rear Axle Angle box on the Data Gathering Worksheet. Figure 14.20.

14 Measuring and Recording Driveline Angles

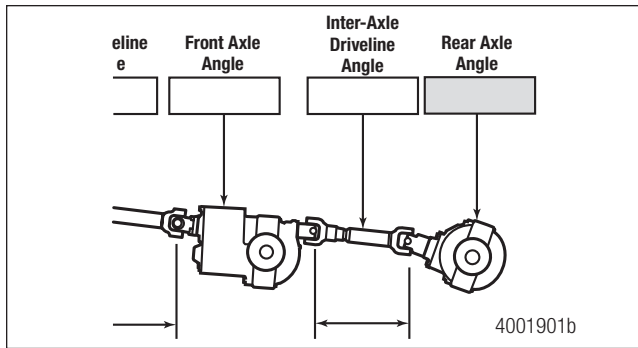

Figure 14.20

When You Finish Measuring the Driveline Angles

1. Set the tractor's parking brake.
2. Remove the blocks from the front tires.
3. You are now ready to enter the dimensions you recorded on the Data Gathering Worksheet into the Meritor Driveline Angle Analysis Program on the disk included with this manual. Figure 14.21.

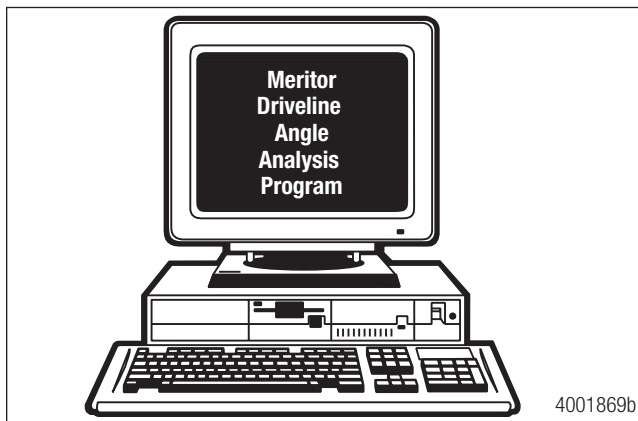

Figure 14.21

Manually Calculating Driveline Angles

If a computer and/or the Meritor Driveline Angle Analysis Program are not available, driveline joint angles can be calculated manually.

To calculate a joint angle, subtract the measured forward component angle from the measured rear component angle for that joint.

Example:

To calculate the first joint angle, you would use the angle measurements for the transmission and the first driveline.

- Transmission Angle = -2.5°
- First Driveline Angle = -1.0°
- First Joint Angle = $-1.0 - (-2.5) = 1.5^\circ$

NOTE: Remember to include the negative sign for negative component angles. Always use a calculator to ensure accurate results with the correct negative or positive designations.

Adjustment

Hints for Driveline Set Up

After analyzing driveline angles, keep the following in mind when performing adjustment or replacement procedures.

- Keep operating angles below five degrees.
- Keep operating angles within one degree of each other.
- Typically, the hypoid and amboid Forward-Rear axle plane is the same as the Engine/Transmission plane (usually 3 to 3.5 degrees).
- Typically, the hypoid Rear-Rear axle plane is 10.5 to 11.5 degrees.
- Typically, on an amboid model, the Rear-Rear axle plane is 3 to 3.5 degrees.

Recommended hypoid driveline angles are shown in Figure 14.22.

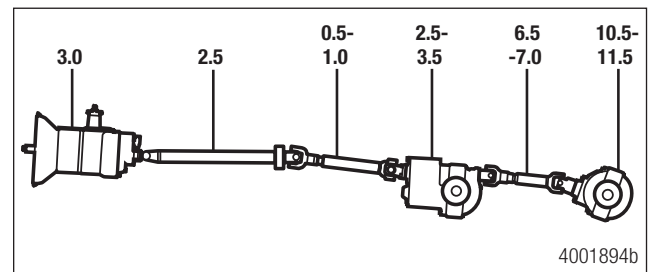

Figure 14.22

Recommended amboid driveline angles are shown in Figure 14.23.

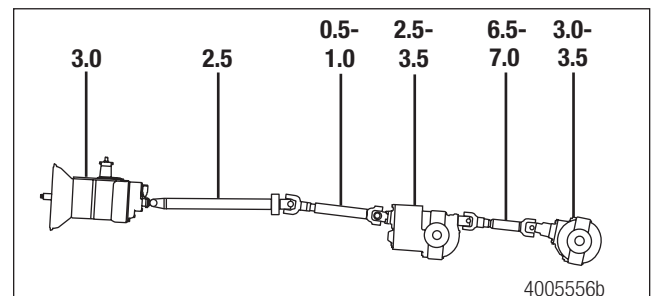

Figure 14.23

14 Measuring and Recording Driveline Angles

Driveline Angle Analysis Program

The [Driveline Angle Analysis Program](#) is used to determine the correct driveline angles for a Class 8 tractor with a two-piece main driveline and inter-axle. The program runs in Adobe Acrobat® Reader software. Refer to the Acrobat® Reader documentation for detailed information on using this program.

Open the Driveline Program

The Driveline Angle Analysis Program is on the CD-ROM included with this maintenance manual. To open the program, place the CD-ROM in the computer CD/DVD drive. The program will automatically launch. A menu page will appear on your screen with three options: View Manual, Run Program and Exit.

If the program does not automatically launch:

1. Click the Windows® Start icon. Click Run.
2. In the Run window, click Browse to find your system's CD/DVD drive (for example, [D:]); or enter your drive in the Open field. Click OK.
3. Double-click the auto folder. Double-click Driveline.exe.

Confirm the Vehicle Ride Height

Begin by confirming that the vehicle ride height is within specification.

1. Click on the **View Ride Height Measurement And Adjustment Procedures** field.
2. Follow the procedures to measure. If necessary, adjust the vehicle ride height.
3. Road test the vehicle to determine if the driveline condition still exists.
4. If the driveline condition was resolved by adjusting the ride height, click on the **Click Here To Exit This Program** field.
5. If the condition still exists, click on the field that applies to the vehicle's driveline configuration. There are currently four configurations covered by the Driveline Angle Analysis Program:
 - Two-piece tandem
 - Two-piece single
 - One-piece single
 - One-piece tandem

Measure the Driveline Angles

Measure the driveline angles listed on the Data Gathering Sheet that apply to the vehicle's driveline configuration. Refer to the procedures in this section.

Clicking on the PHOTO buttons displays examples of where to measure each angle.

NOTE: Data Gathering Worksheets are provided at the end of this manual. A worksheet can be taken to the vehicle, where you can record the relevant information.

Enter the Data

1. Enter the following optional information in the appropriate fields at the top of the screen. Figure 14.24.

Type	Phasing Types	Residuals	Driveline Speed
1	Parallel - Parallel	0.000	10 RPM
		0.000	1 rads/sec
		0.000	
		0.000	

Figure 14.24

- Customer name and phone numbers
- OEM
- Model
- VIN
- Unit
- Year
- DSM name

14 Measuring and Recording Driveline Angles

NOTE: You must correctly enter information in Step 2 through Step 5 to obtain a correct analysis. If fields are left blank, you will not obtain an analysis.

2. Enter the maximum engine RPM. Figure 14.24.
3. Enter the transmission overdrive ratio. This value should be less than 1. For direct drive applications, enter 1. Figure 14.24. Click the **Select By Vendor** pull-down menu. Click on the **GO** button. The screen will display lists of transmissions by manufacturer. You can select your specific transmission model and ratio from these lists.

NOTE: The phasing type is not required for angle analysis of one-piece driveline configurations.

4. Enter the driveline phasing type. Click on the **VIEW** button next to the **Phasing Type** field to view examples of the four phasing types. Figure 14.25. Passing the cursor over the example types will close them.

Common driveline phasing types are: Figure 14.26.

- Type 1: Parallel-Parallel
- Type 2: Crossed-Parallel
- Type 3: Parallel-Crossed
- Type 4: Crossed-Crossed

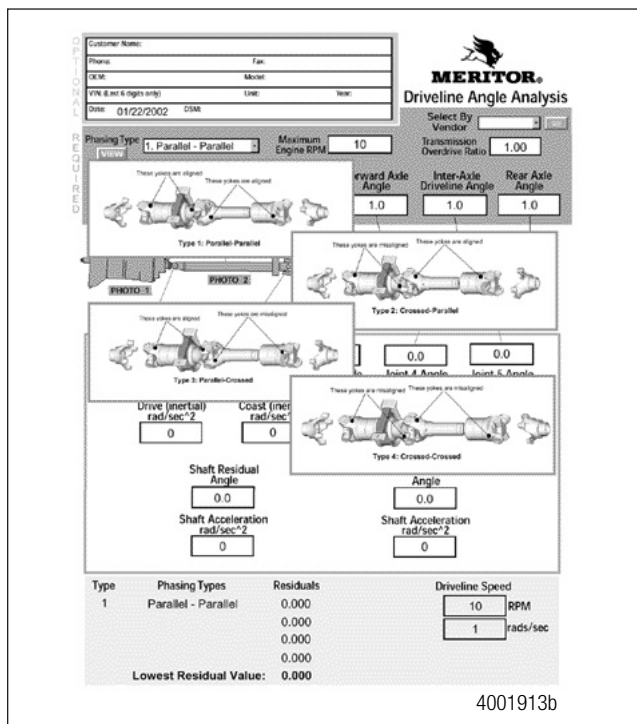

Figure 14.25

NOTE: Each driveline section is designated either PARALLEL or CROSSED, which is determined by the position of the yokes at either end of the section. If the yoke lugs on the two yokes are aligned, the section is PARALLEL.

If the yoke lugs are not aligned (opposite or crossed), the section is CROSSED. Both sections are considered when determining the phasing type.

14 Measuring and Recording Driveline Angles

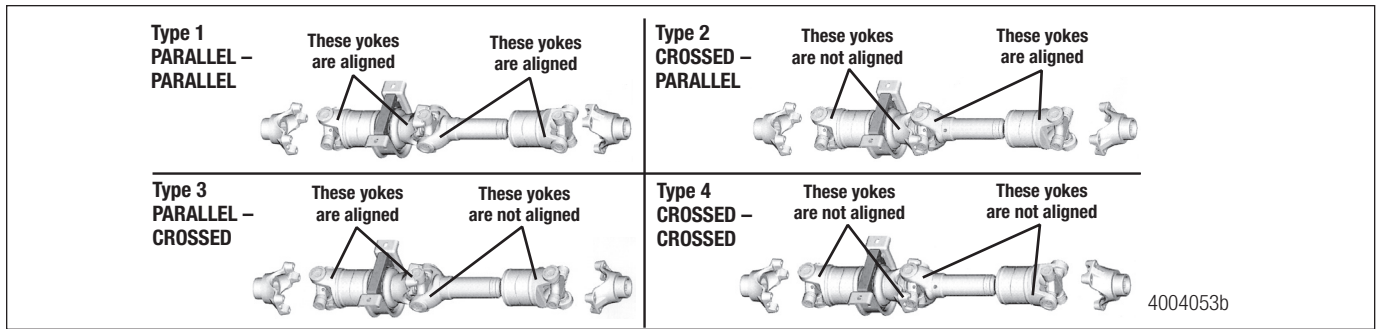

Figure 14.26

5. Enter the driveline angle values that you measured on the vehicle.
6. After you've entered all of the required information, click anywhere on the screen to complete the calculations. Values will appear in the driveline analysis fields, which are located below the driveline diagram. Values shown in red are not acceptable and must be corrected.

If some values are shown in red: Click the **Exceeds . . .** field located beneath the data fields, to display the troubleshooting boxes.

Measuring and Recording Driveline Angles: Plan View

Tools Needed

- Tape measure
- Carpenter's square or straightedge
- A plumb bob

Prepare the Vehicle

DANGER

Park the vehicle on a level surface. Block the wheels to prevent the vehicle from moving. Support the vehicle with safety stands. NEVER work under a vehicle supported only by jacks. Jacks can slip and fall over. Failure to use safety stands can result in death or serious personal injury and damage to components.

WARNING

To prevent eye injury, always wear eye protection when performing vehicle maintenance or service.

1. Park the vehicle on a level surface. Do not engage the brakes or the parking brake.
2. Verify that all tires are on a level surface and inflated to the specified pressure.
3. Block the front tires at both the front and rear.

For Air-Ride-Equipped Axles

1. Build air pressure to at least 115 psi (792.35 kPa).
2. Deflate air from the air bags. Use the dash-mounted deflate switch or release the air pressure through the valve at the rear of the vehicle.
3. Allow the air bags to inflate completely.
4. Measure the ride height with a tape measure or calipers. If necessary, adjust the ride height to the correct vehicle manufacturer's specifications.

14 Measuring and Recording Driveline Angles

Measure Driveline Angles

Measure the plan view angles by using either Method 1 or Method 2.

Method 1

1. Measure and record the side view angles. Refer to the procedure in this section.
2. Measure the length of the driveline from the center of the transmission universal joint to the center of the carrier universal joint. Figure 14.27.

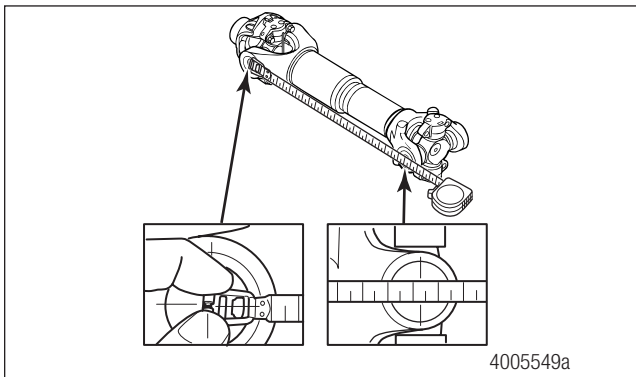

Figure 14.27

3. Measure the distance from the center of the transmission universal joint to the frame rail. Use a carpenter's square or other straightedge if needed. Figure 14.28.

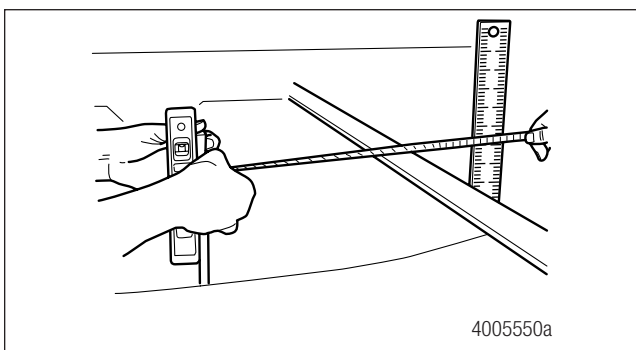

Figure 14.28

4. Measure the distance from the center of the carrier universal joint to the frame rail. Use a carpenter's square or other straightedge if needed. Figure 14.28.
5. The universal joint plan view angle can now be calculated by using Formula 1.

Method 2

1. Measure the length of the driveline from the center of the transmission universal joint to the center of the carrier universal joint. Figure 14.27.
2. Attach a plumb bob to the frame rail in line with the transmission universal joint. Mark a point on the ground just below the plumb bob. Figure 14.29.

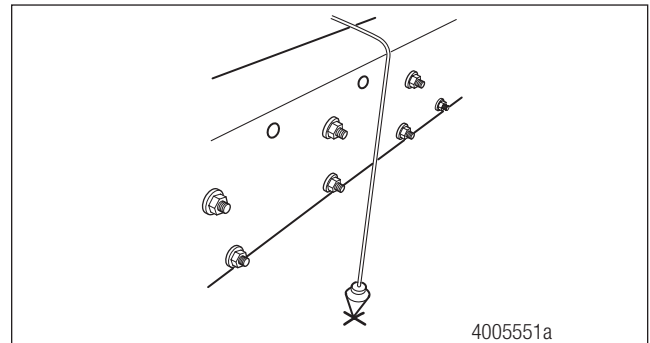

Figure 14.29

3. Repeat Step 2 for points in line with the carrier universal joint and a spot in between the universal joints.
4. Draw a straight line connecting the points on the ground. Figure 14.30.

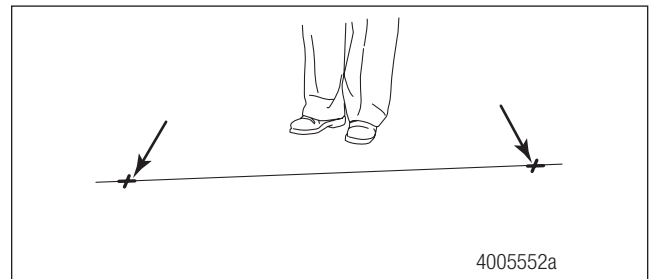

Figure 14.30

5. Attach a plumb bob to the center of the transmission universal joint. Mark a point on the ground just below the plumb bob. Figure 14.31.

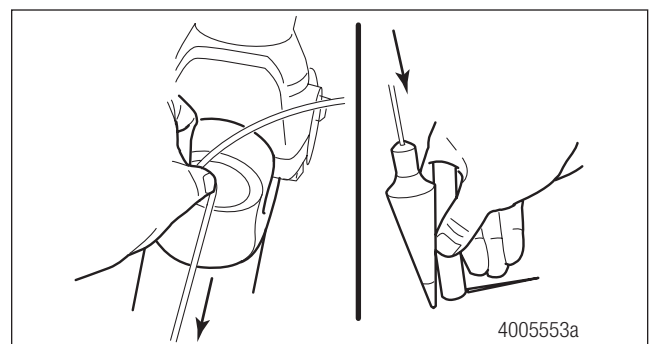

Figure 14.31

14 Measuring and Recording Driveline Angles

- Repeat Step 5 for the carrier universal joint.
- Using a carpenter's square, measure the distance from the transmission universal joint point to the frame rail reference line. Figure 14.32.

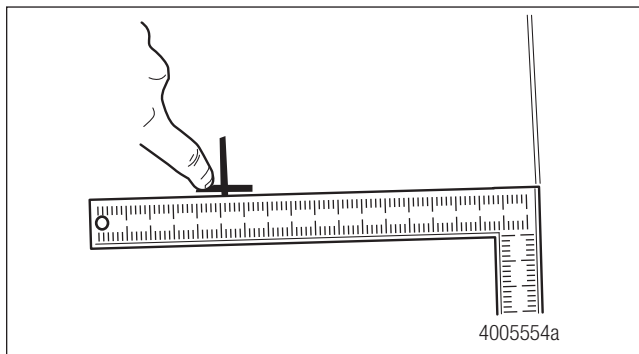

Figure 14.32

- Repeat Step 7 for the carrier universal joint.
- The universal joint plan view angle (true joint angles) can now be calculated by using Formula 1.

Calculate Driveline Angles

- Measure and record the side view angles. Refer to the procedure in this section. Figure 14.33 is shown as a reference.

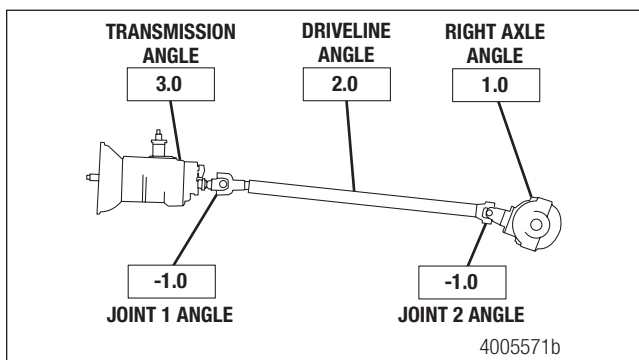

Figure 14.33

- Calculate the plan view universal joint angles using Formula 1. Figure 14.34.

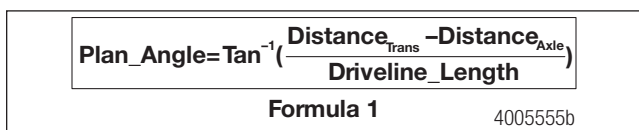

Figure 14.34

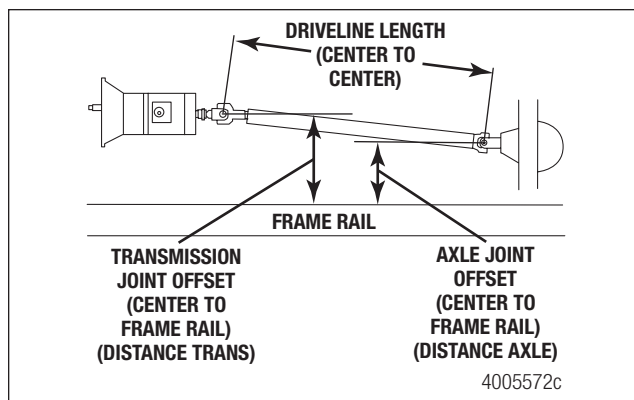

Figure 14.35

NOTE: Both joints will have the same plan view angle. Figure 14.35 is shown as a reference.

- Calculate the compound universal joint angles using Formula 2. Figure 14.36.

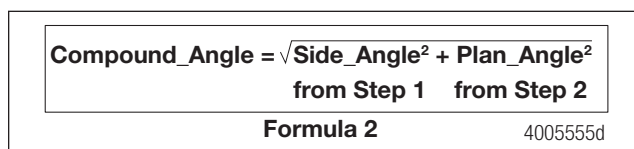

Figure 14.36

The compound universal joint angles (true universal joint operating angles) should not be greater than 5 degrees during vehicle operation, and the difference between the carrier-driveline joint angle and transmission-driveline joint angle should not be greater than 1.5 degrees to ensure optimal operation of the drivetrain.

15 Driveline Balance Weight

Driveline Balance Weight

When re-balancing drivelines, proper driveline weights are necessary. Meritor's recommended practices for welding balance weights are shown in Figure 15.1, Figure 15.2, Figure 15.3, Figure 15.4 and Figure 15.5.

NOTE: For best results, it may be necessary to balance connected shafts assembled together as a system.

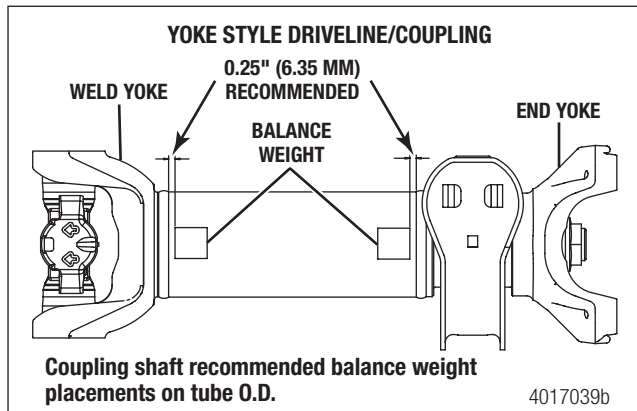

Figure 15.1

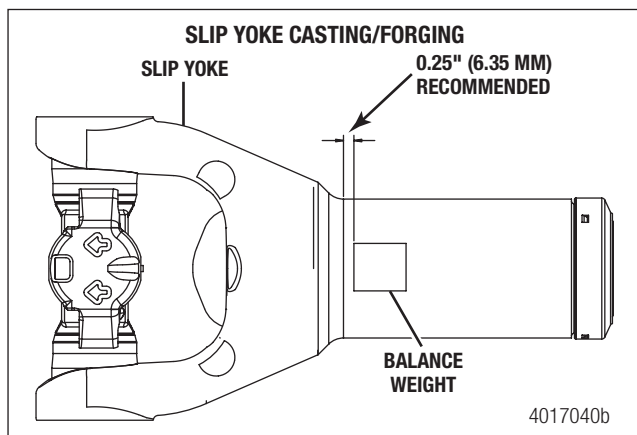

Figure 15.2

⚠ CAUTION

Slip yokes are cast iron material. If you are attaching a balance weight to a slip yoke, proper welding procedures and materials must be used when welding to cast iron materials. Failure to do so may result in damage to the slip yoke.

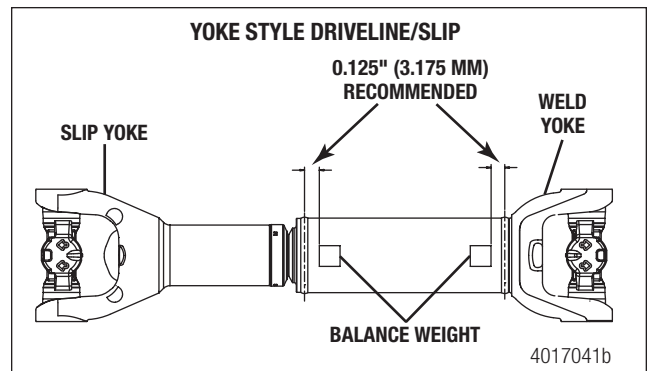

Figure 15.3

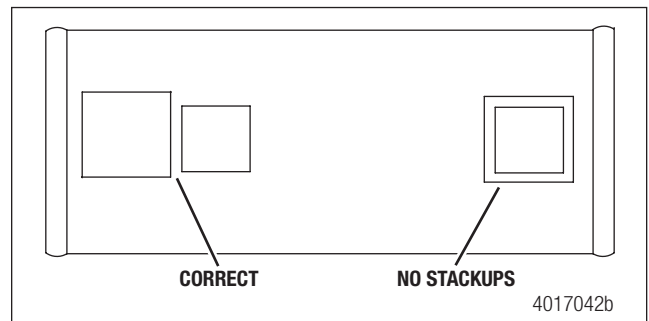

Figure 15.4

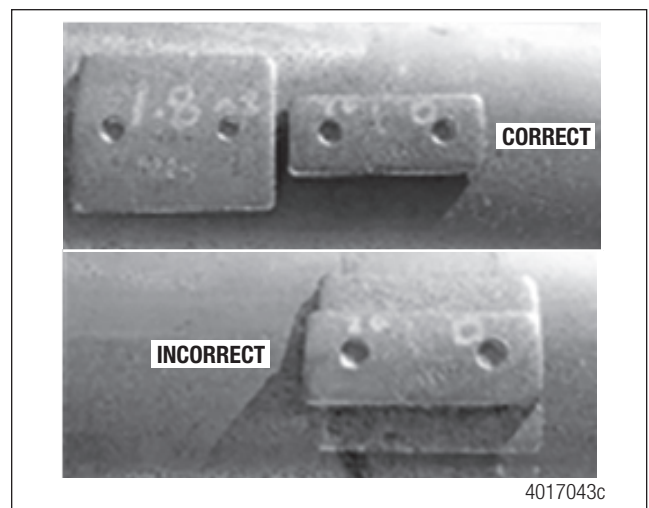

Figure 15.5

Special Tools

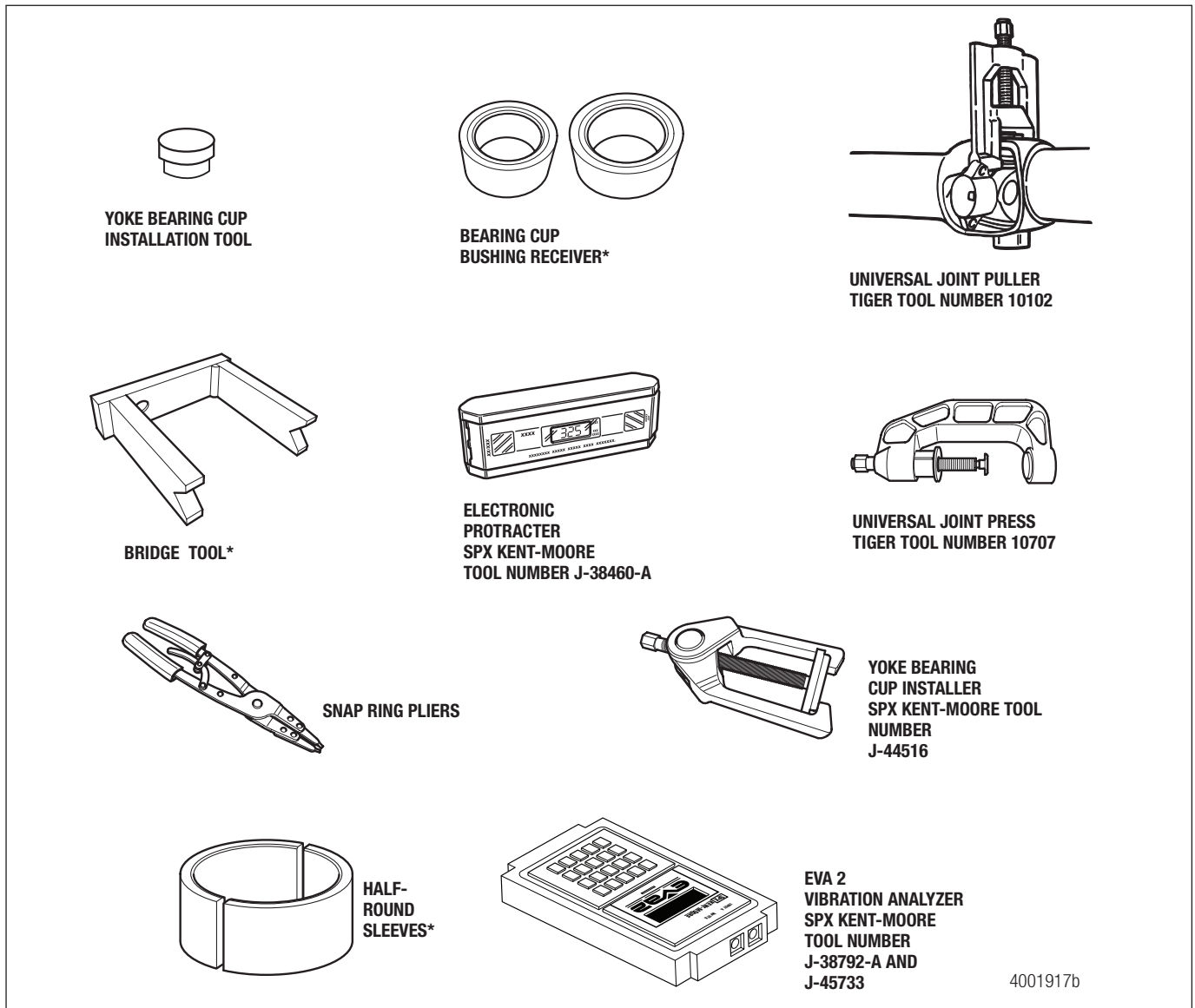

Figure 16.1

Refer to the Service Notes page on the front inside cover of this manual for information on how to obtain these tools.

*See Tool Drawings.

16 Special Tools

Tool Drawings

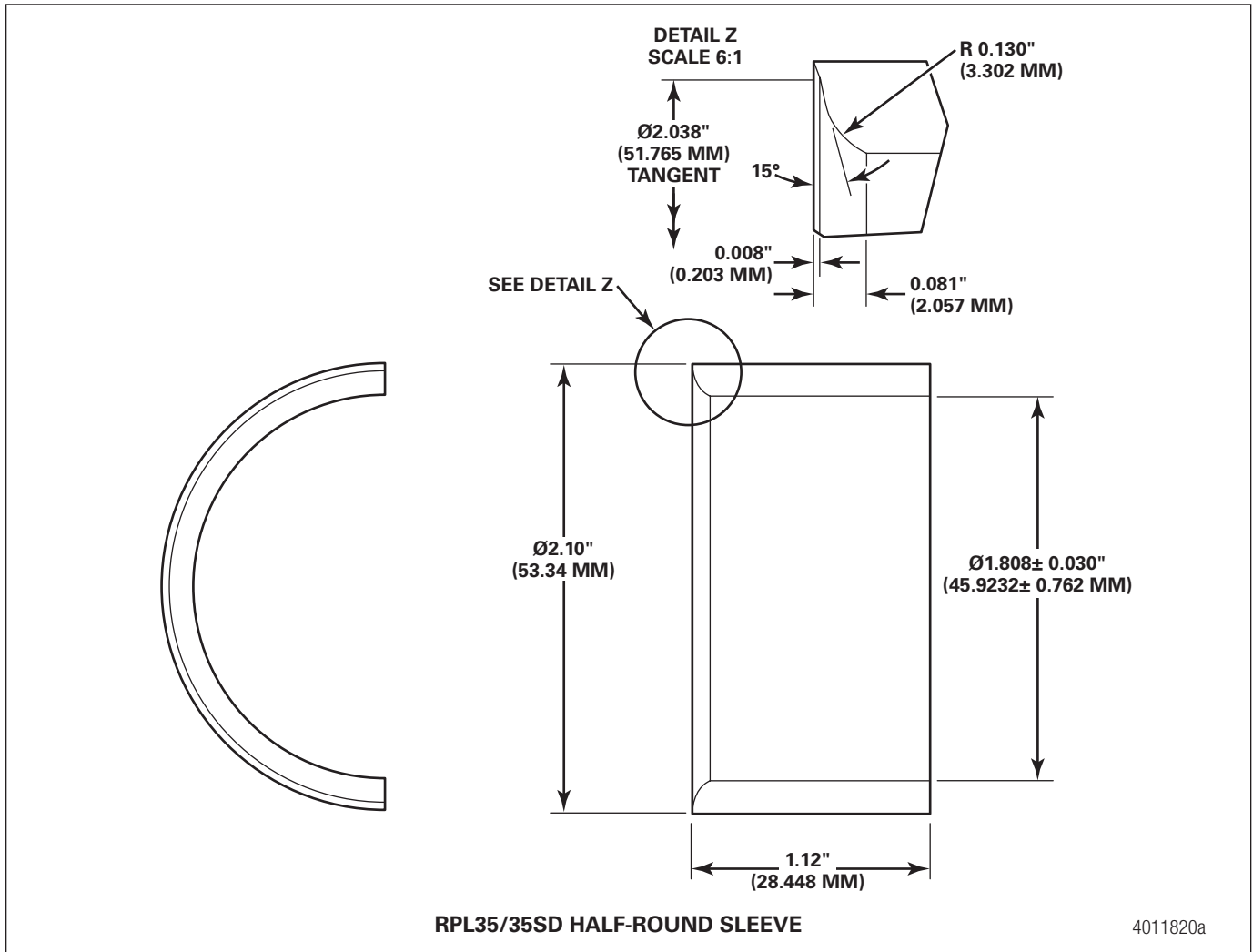

Figure 16.2

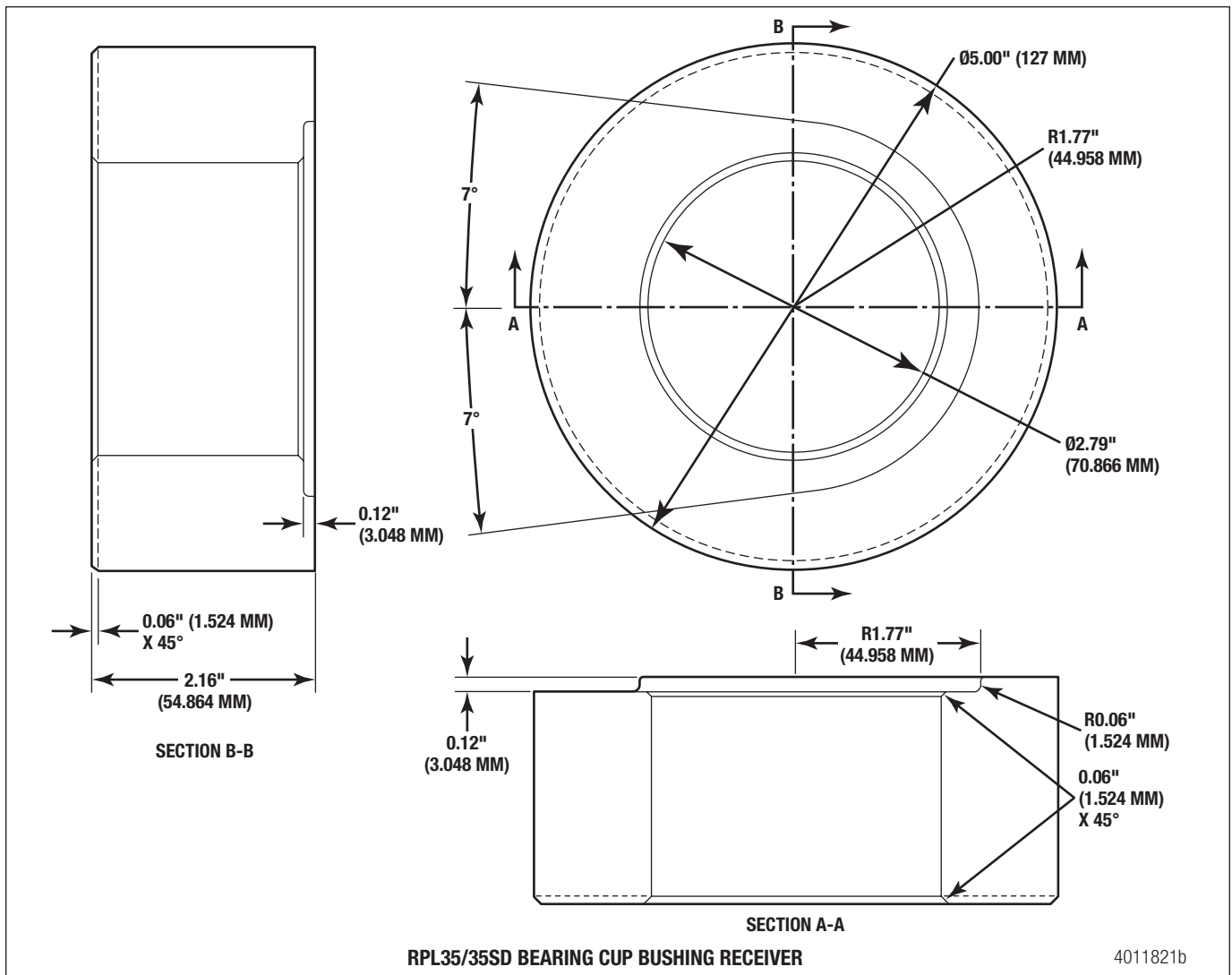

Figure 16.3

16 Special Tools

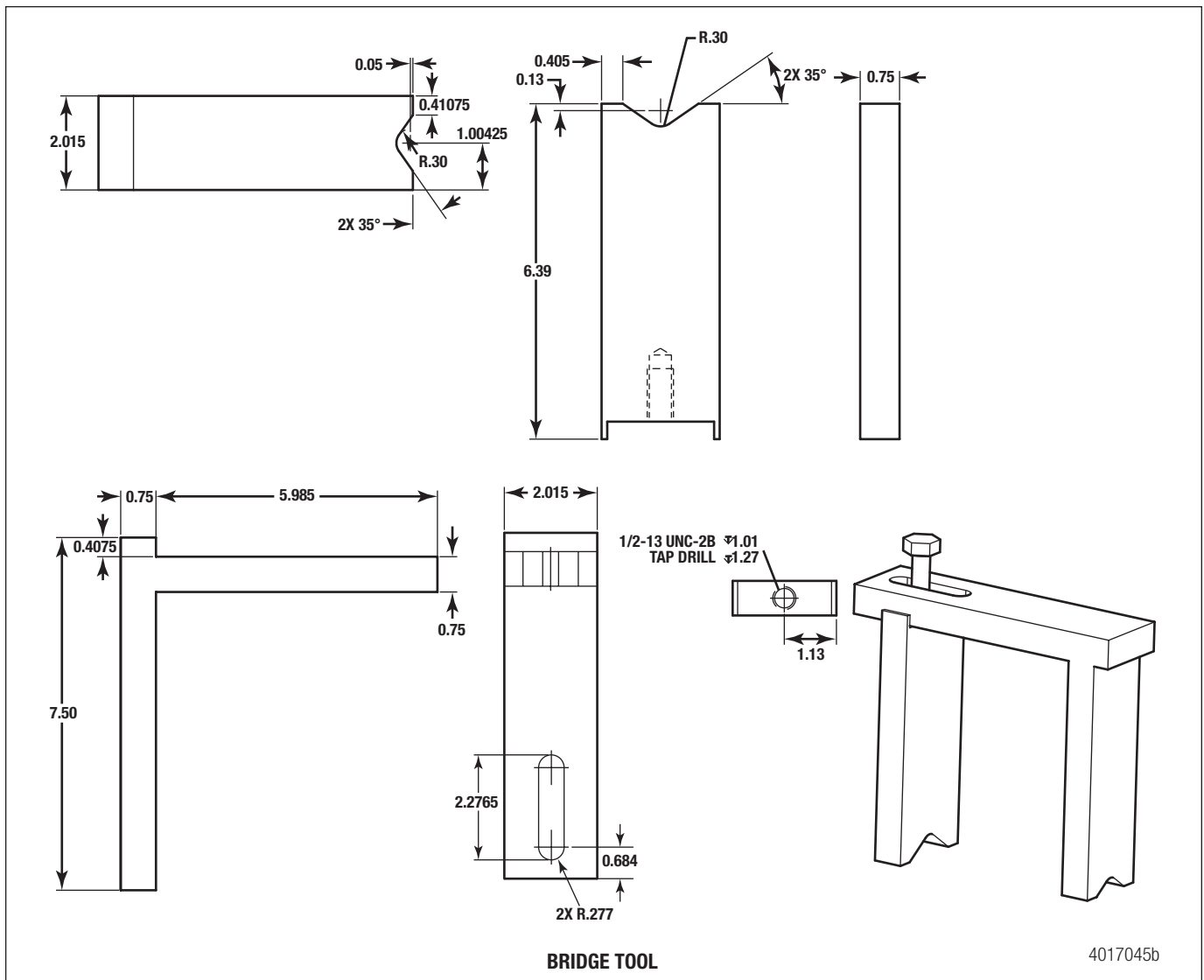

Figure 16.4

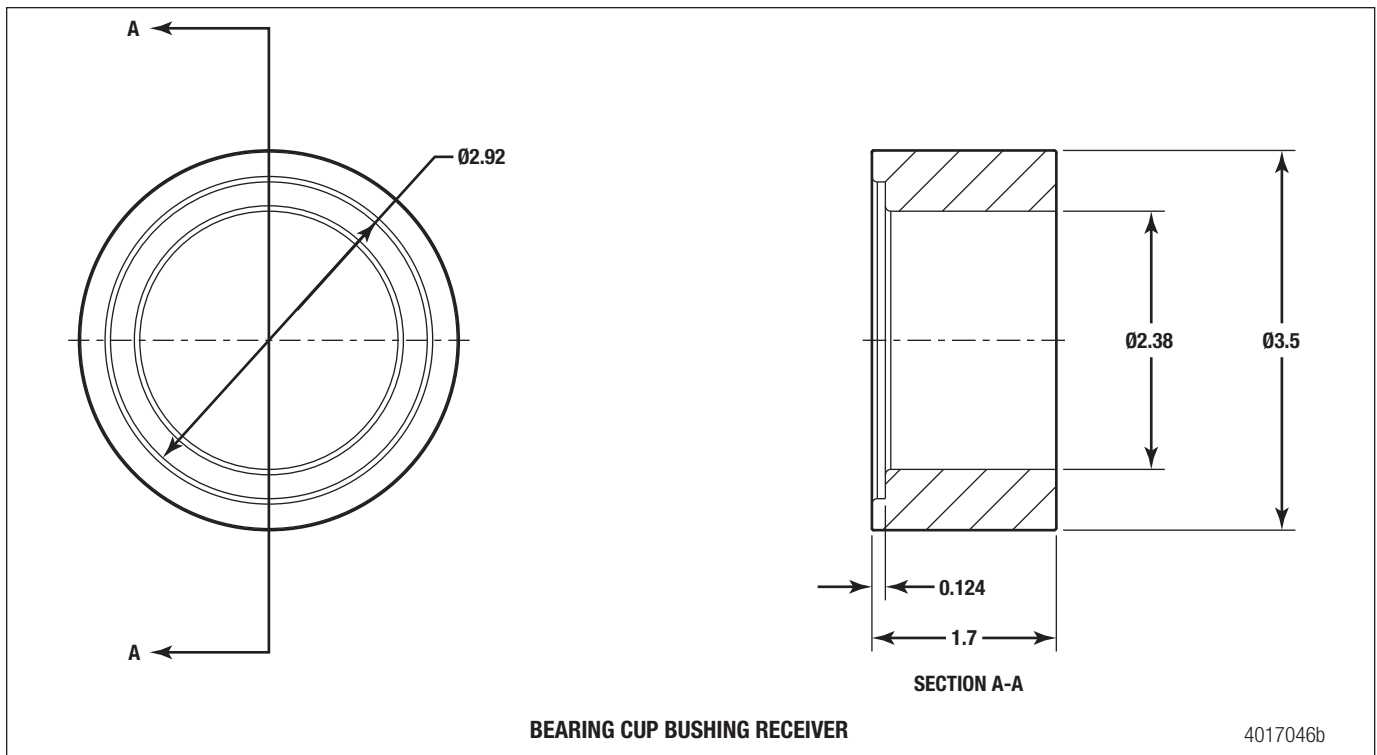

Figure 16.5

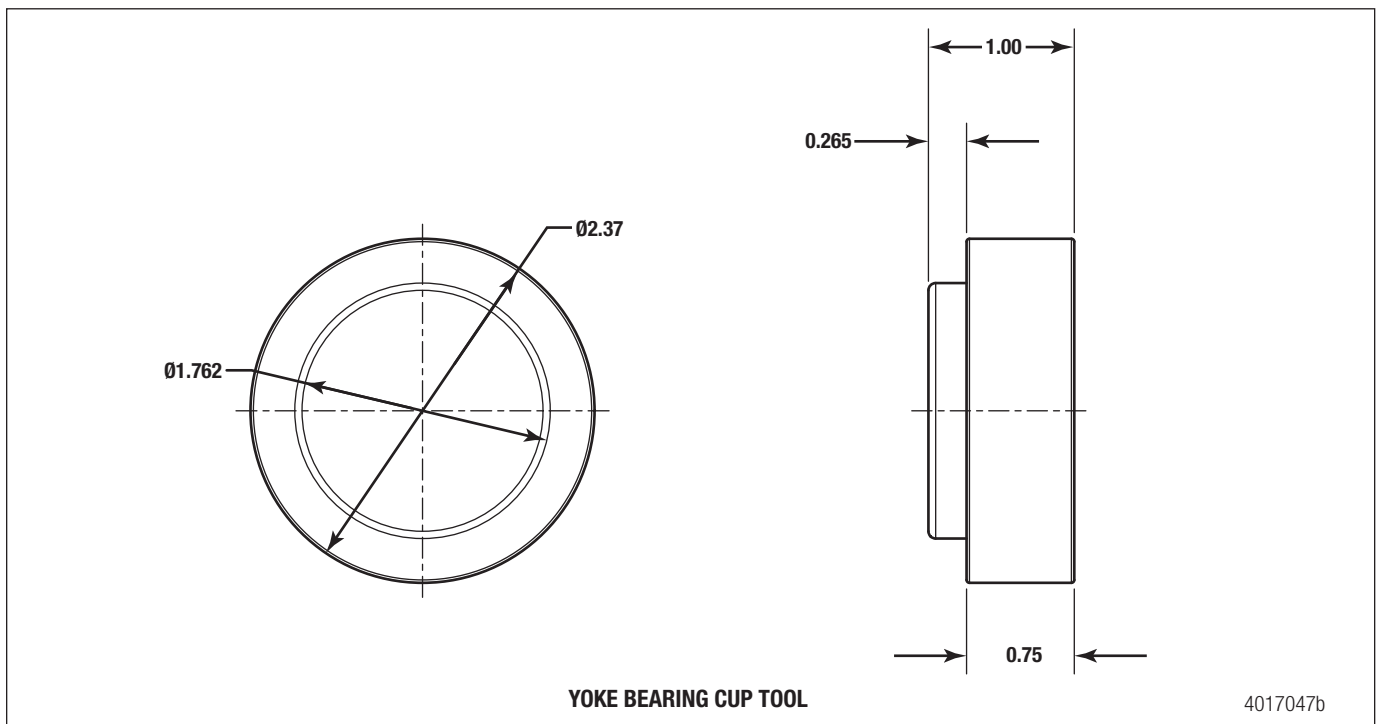

Figure 16.6

17 Glossary

Glossary

Bearing Stub— A splined stub that is pressed into and welded onto the tubing of a non-slip coupling shaft assembly.

Brinelling— Grooves worn into a cross and bearing kit trunnion by the needle rollers due to insufficient lubrication, excessive load or incorrect driveline angles.

Cardan Universal Joint— A mechanical device in which a cross and bearing kit connects yokes of a driving and a driven shaft.

Cross— The cross-shaped “body” of a universal joint kit.

Cross and Bearing Kit— Cross-shaped body with swivel bearings over each end that joins two driveline yokes in a Cardan universal joint. Cross and bearing kits are sometimes referred to as a “universal joint” or “universal joint kit.”

End Yoke— A yoke mounted to an input or output transmission shaft or axle shaft and secured by a nut and washer.

Galling— A transfer or displacement of metal. Galling can be caused by lack of lubricant, incorrect lubrication or excessive loads.

Gear Efficiency (e)— Ratio of power out of a gear set and the power provided into that gear set.

Hinging-Loose Condition— Usually within a slip section, which causes vibration through the driveline.

Needle Cup— A cross and bearing component kit that fits over the trunnion and holds the needle rollers.

Needle Rollers— Cylindrical bearings positioned around the bore of the needle cup that enable the bearing to rotate freely on the trunnion.

Non-Slip Coupling Shaft Assembly— A driveline of fixed length consisting of a weld yoke, tubing, bearing stub, center bearing kit and an end yoke with splined hole.

Operating Angle— The angle defined by the intersection of the centerlines of two shafts connected by a universal joint.

Permalube Universal Joint— A permanently lubricated and sealed universal joint that does not require regular lubrication.

Permalube Driveline— A driveline incorporating permanently lubricated universal joints with a permanently lubricated and sealed slip section. The entire assembly does not require regular lubrication.

Phasing— Correct alignment between yokes at each end of a driveline.

Round Bearing— A type of bearing cup used in cross and bearing kits for Cardan universal joints.

Runout— A condition in which a component’s radius dimensions vary when the component is rotated. Excessive runout can negatively affect driveline operation.

Slip Yoke— A driveline assembly component that allows for driveline length changes by absorbing axial (backward-forward) movement of the driveline caused by axle articulation.

Standard Slip Assembly— A driveline assembly consisting of a slip yoke, spline plug, tubing and weld yoke.

Torsional Acceleration— Excessive rotation speed in an individual section of the driveline. Usually due to incorrect phasing.

Trunnion— Ground surfaces of the universal joint crossover in which the bearing cups fit.

Universal Joint— A joint providing a flexible coupling that allows torque transmission and rotary motion from one shaft to another, as well as angular changes in shaft alignment.

Welch Plug— A plate or cup used to seal the hole in the throat of a slip yoke and retain grease in the spline area.

Weld Yoke— A type of permanent fitting, welded to one or both ends of a driveline, designed for a specific combination of tubing and universal joint kit.

Wing Bearing— A type of bearing cup used in cross and bearing kits for specific types of yokes in Cardan universal joints. The cup has two flanges through which drilled or threaded holes extend to allow for cross and bearing kit mounting.

Important Information

Data Gathering Sheets

Customer Name:						
Phone: ()		Fax: ()				
OEM:		Model:				
VIN: (Last 6 digits only)		Unit:			Year:	
Date:		DSM:				

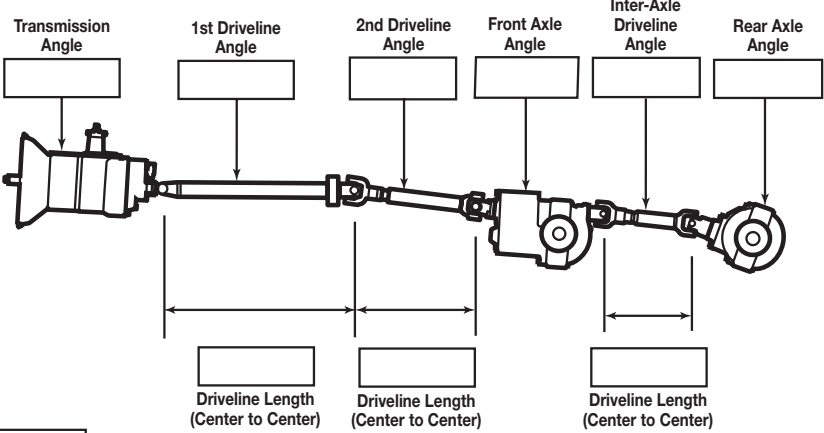

MERITOR®
Driveline Angle Analysis
Data Gathering Sheet
Two-Piece, Tandem

Phasing Type <input style="width: 60px;" type="text"/> Maximum Engine RPM <input style="width: 60px;" type="text"/> Transmission Top Gear Ratio <input style="width: 60px;" type="text"/> Rear Suspension Ride Height <input style="width: 60px;" type="text"/> Maximum Engine HP <input style="width: 60px;" type="text"/> Clutch Model <input style="width: 60px;" type="text"/> Transmission Model <input style="width: 120px;" type="text"/> Main Driveline Series <input style="width: 60px;" type="text"/> Axle Model <input style="width: 60px;" type="text"/> I/A Driveline Series <input style="width: 60px;" type="text"/> Tire Size <input style="width: 60px;" type="text"/> Ratio <input style="width: 60px;" type="text"/>	
---	---

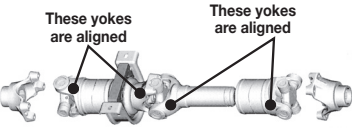
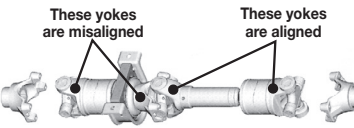
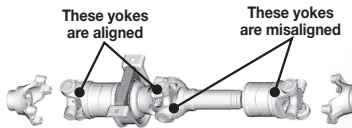
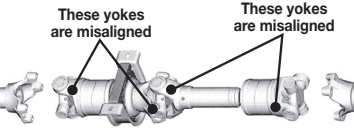
<p>Type 1 PARALLEL – PARALLEL</p>  <p>These yokes are aligned</p>  <p>These yokes are misaligned</p> <p>These yokes are aligned</p>	<p>Type 2 CROSSED – PARALLEL</p>
<p>Type 3 PARALLEL – CROSSED</p>  <p>These yokes are aligned</p> <p>These yokes are misaligned</p>	<p>Type 4 CROSSED – CROSSED</p>  <p>These yokes are misaligned</p> <p>These yokes are misaligned</p>

Before you measure a component, go to the side of the vehicle and look at the driveline:

- If the **FRONT** of the component is **HIGHER** than the **REAR** of the component, the dimension will be **positive (+)**.
- If the **FRONT** of the component is **LOWER** than the **REAR** of the component, the dimension will be **negative (-)**.

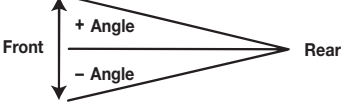

Assumptions

1. Drivelines are in the same plane. The top view shows all drivelines in a straight line.
 For drivelines outside of the same plane, measure the offsets of each joint to the frame. Measure joint center to joint center lengths of each shaft. Fax this information to OnTrac's Customer Service Center at 248-435-5580 or call the Center at 866-OnTrac1 (668-7221) for assistance.
2. Drivelines are balanced according to Meritor's driveline specifications.

4001918c

Figure 18.1

18 Appendix

Customer Name:		
Phone: ()	Fax: ()	
OEM:	Model:	
VIN: (Last 6 digits only)	Unit:	Year:
Date:	DSM:	

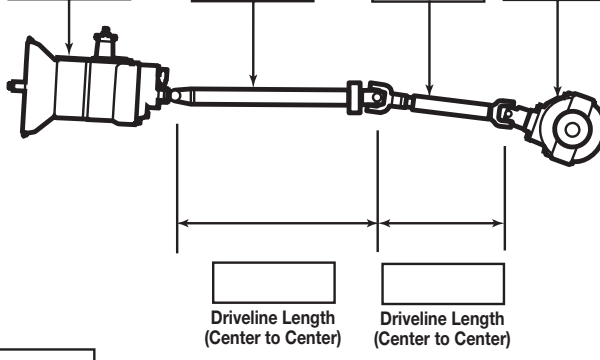

MERITOR®
Driveline Angle Analysis
Data Gathering Sheet
Two-Piece, Single

Phasing Type	<input type="text"/>	Transmission Angle	<input type="text"/>	1st Driveline Angle	<input type="text"/>	2nd Driveline Angle	<input type="text"/>	Rear Axle Angle	<input type="text"/>			
Maximum Engine RPM	<input type="text"/>											
Transmission Top Gear Ratio	<input type="text"/>											
Rear Suspension Ride Height	<input type="text"/>											
Maximum Engine HP	<input type="text"/>											
Clutch Model	<input type="text"/>											
Transmission Model	<input type="text"/>											
Main Driveline Series	<input type="text"/>											
Axle Model	<input type="text"/>								I/A Driveline Series	<input type="text"/>	Tire Size	<input type="text"/>
Ratio	<input type="text"/>											
									Driveline Length (Center to Center)	<input type="text"/>	Driveline Length (Center to Center)	<input type="text"/>

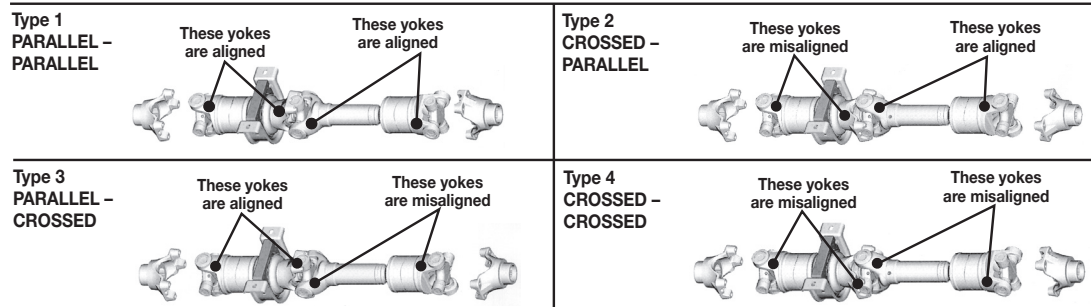

Before you measure a component, go to the side of the vehicle and look at the driveline:

- If the **FRONT** of the component is **HIGHER** than the **REAR** of the component, the dimension will be **positive (+)**.
- If the **FRONT** of the component is **LOWER** than the **REAR** of the component, the dimension will be **negative (-)**.

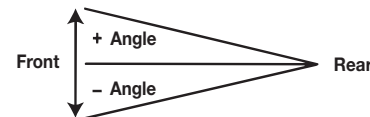

Assumptions

1. Drivelines are in the same plane. The top view shows all drivelines in a straight line.

For drivelines outside of the same plane, measure the offsets of each joint to the frame. Measure joint center to joint center lengths of each shaft. Fax this information to OnTrac's Customer Service Center at 248-435-5580 or call the Center at 866-OnTrac1 (668-7221) for assistance.

2. Drivelines are balanced according to Meritor's driveline specifications.

4004054b

Figure 18.2

Customer Name:		
Phone: ()	Fax: ()	
OEM:	Model:	
VIN: (Last 6 digits only)	Unit:	Year:
Date:	DSM:	

MERITOR
Driveline Angle Analysis
Data Gathering Sheet
One-Piece, Tandem

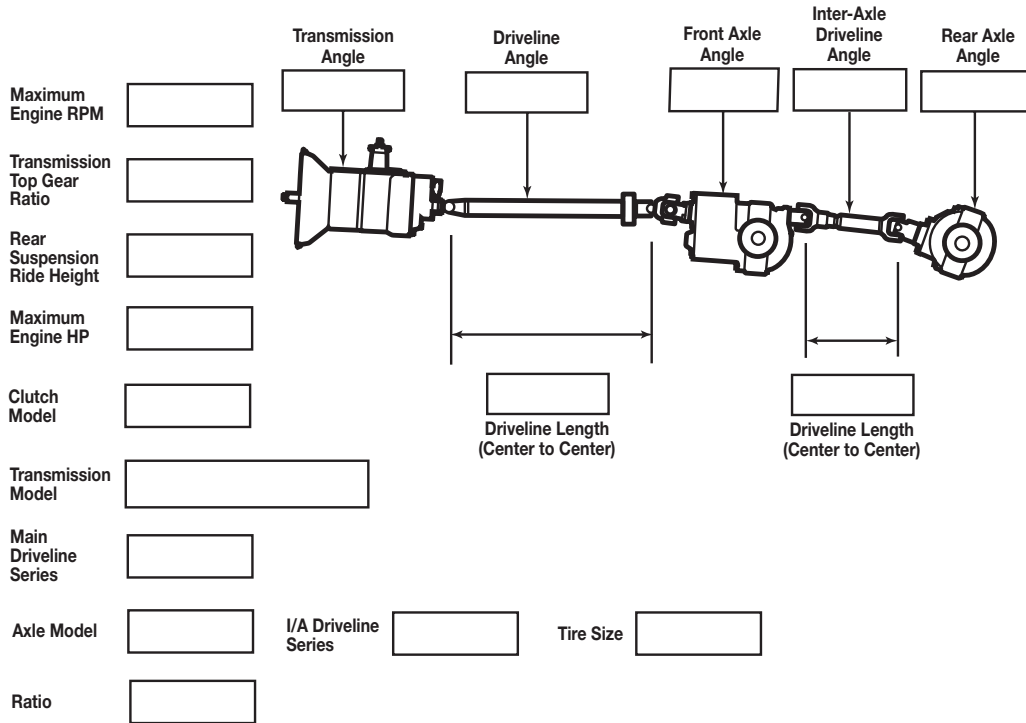

Before you measure a component, go to the side of the vehicle and look at the driveline:

- If the **FRONT** of the component is **HIGHER** than the **REAR** of the component, the dimension will be **positive (+)**.
- If the **FRONT** of the component is **LOWER** than the **REAR** of the component, the dimension will be **negative (-)**.

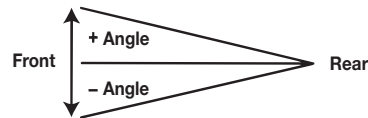

Assumptions

1. Drivelines are in the same plane. The top view shows all drivelines in a straight line.

For drivelines outside of the same plane, measure the offsets of each joint to the frame. Measure joint center to joint center lengths of each shaft. Fax this information to OnTrac's Customer Service Center at 248-435-5580 or call the Center at 866-OnTrac1 (668-7221) for assistance.

2. Drivelines are balanced according to Meritor's driveline specifications.

4004055b

Figure 18.3

18 Appendix

Customer Name:		
Phone: ()	Fax: ()	
OEM:	Model:	
VIN: (Last 6 digits only)	Unit:	Year:
Date:	DSM:	

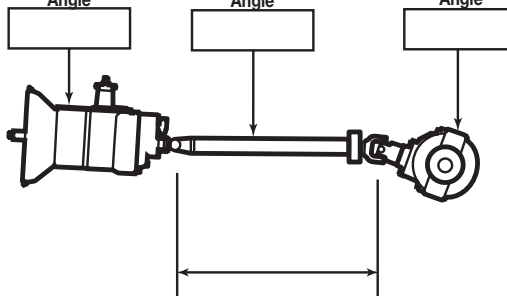

MERITOR®
Driveline Angle Analysis
Data Gathering Sheet
One-Piece, Single

		Transmission Angle	1st Driveline Angle	Rear Axle Angle	
Maximum Engine RPM	<input type="text"/>	<input type="text"/>	<input type="text"/>	<input type="text"/>	
Transmission Top Gear Ratio	<input type="text"/>				
Rear Suspension Ride Height	<input type="text"/>				
Maximum Engine HP	<input type="text"/>				
Clutch Model	<input type="text"/>				
Transmission Model	<input type="text"/>	<input type="text"/> Driveline Length (Center to Center)			
Main Driveline Series	<input type="text"/>				
Axle Model	<input type="text"/>	I/A Driveline Series	<input type="text"/>	Tire Size	<input type="text"/>
Ratio	<input type="text"/>				

Before you measure a component, go to the side of the vehicle and look at the driveline:

- If the **FRONT** of the component is **HIGHER** than the **REAR** of the component, the dimension will be **positive (+)**.
- If the **FRONT** of the component is **LOWER** than the **REAR** of the component, the dimension will be **negative (-)**.

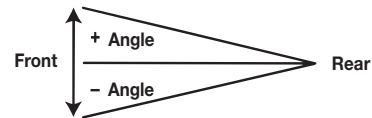

Assumptions

1. Drivelines are in the same plane. The top view shows all drivelines in a straight line.
 For drivelines outside of the same plane, measure the offsets of each joint to the frame. Measure joint center to joint center lengths of each shaft. Fax this information to OnTrac's Customer Service Center at 248-435-5580 or call the Center at 866-OnTrac1 (668-7221) for assistance.
2. Drivelines are balanced according to Meritor's driveline specifications.

4004056b

Figure 18.4



Meritor Heavy Vehicle Systems, LLC
2135 West Maple Road
Troy, MI 48084 USA
866-OnTrac1 (668-7221)
meritor.com

Information contained in this publication was in effect at the time the publication was approved for printing and is subject to change without notice or liability. Meritor Heavy Vehicle Systems, LLC, reserves the right to revise the information presented or to discontinue the production of parts described at any time.

Copyright 2022
Meritor Inc.
All Rights Reserved

Printed in USA

MM-96147
Revised 08-22
(16579)