



Service Parts Instructions

R 900 Series Drive Axle Bearing Adjustment Using Doctor Preload

Axles Equipped with Temper-Loc® Spindle
Nuts

Hazard Alert Messages

Read and observe all Warning and Caution hazard alert messages in this publication. They provide information that can help prevent serious personal injury, damage to components, or both.

WARNING

To prevent serious eye injury, always wear safe eye protection when you perform vehicle maintenance or service.

Park the vehicle on a level surface. Block the wheels to prevent the vehicle from moving. Support the vehicle with safety stands. Do not work under a vehicle supported only by jacks. Jacks can slip or fall over. Serious personal injury and damage to components can result.

How to Obtain Additional Maintenance, Service and Product Information

Refer to Maintenance Manual MM-0409, Wheel-End Components. To obtain this publication, visit Literature on Demand at meritor.com.

Adjusting Bearing Preload Using Doctor Preload

Doctor Preload is intended for use only with conventional hubs with Temper-Loc® spindle nuts. Remove all bearing spacers from pre-adjusted hub assemblies before adjusting with Doctor Preload. Do NOT attempt to adjust a unitized hub assembly using the Doctor Preload system. Figure 1.



Figure 1

Inspect the Components Before Starting Bearing Adjustment

Inspect all wheel end components. Repair any damage to the spindle threads so that the Temper-Loc spindle nut is able to thread completely onto the spindle.

Prepare the Wheel End for Bearing Adjustment

Always be sure the hub is fully seated before adjusting with Doctor Preload. Thread the correct size Temper-Loc nut onto the spindle. Using a bar and socket, tighten the Temper-Loc nut to drive the hub **solidly** against the axle. Loosen the nut one-half turn. Finally, hand-tighten the nut until it first touches the face of the outer bearing.

Adjust the Bearings Using Doctor Preload

1. To attach Doctor Preload, first adjust the yellow T-handle so that it is "loosened" to the point that it completely covers the threads on the shaft of the spindle adapter shaft as shown. Figure 2 and Figure 3.

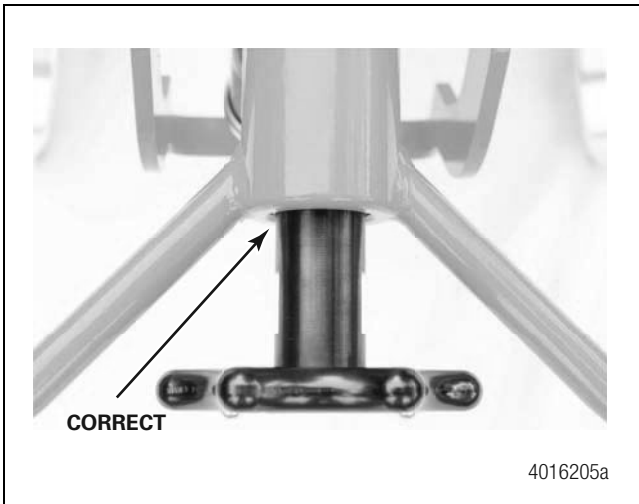

Figure 2

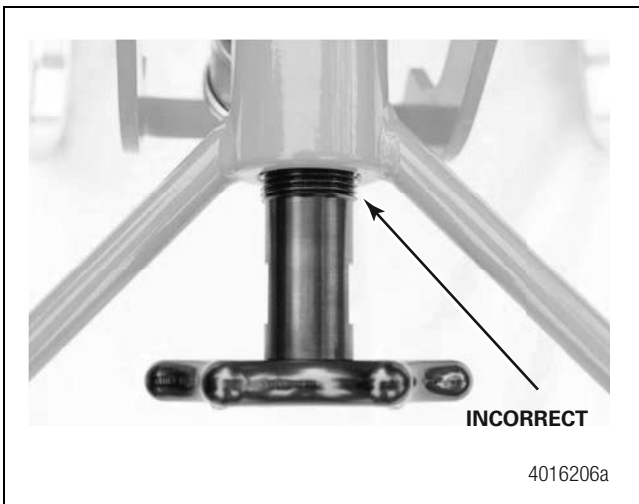

Figure 3

2. Hold Doctor Preload by the Gauge Guard Handle with one hand, or alternatively, by cradling the main body of the tool in the palm of one hand and the Circular KeyFinder with the other hand. Locate the position of the keyway on the spindle. Rotate the Circular KeyFinder until the Key is approximately lined up with the keyway. Guide the spring-loaded load arms around two flats of the nut (not over any of the “points” of the nut) by controlling the position of the load arms with the finger tabs at the end of the load arms, or by gripping each of the load arms while slightly rotating the Circular KeyFinder until the Key is engaged in the keyway. Carefully engage the spindle adapter thread on the spindle until the O-ring in the spindle adapter bottoms out against the spindle face. Figure 4.

NOTE: A two-thread turn is adequate to engage the adapter. Do not tighten the star-handle once the O-ring makes contact with the spindle. Over-tightening the spindle adapter against the spindle can damage the Doctor Preload tool.

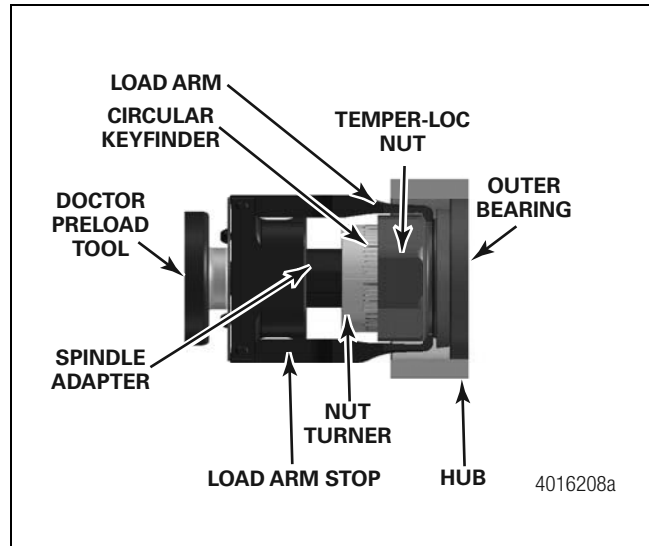

Figure 4

3. At this point, the inner surfaces of both of the two load arms should be flat against the sides of the load arm stops. Figure 5 and Figure 6. If one or both are skewed out of alignment, slowly push and pull the load arm assembly along the shaft until the tips of the load arms spring into their correct position behind the Temper-Loc nut. Check to be sure the load arms are correctly located in the backface relief of the Temper-Loc nut and making contact with the outer bearing cone as shown in Figure 4.

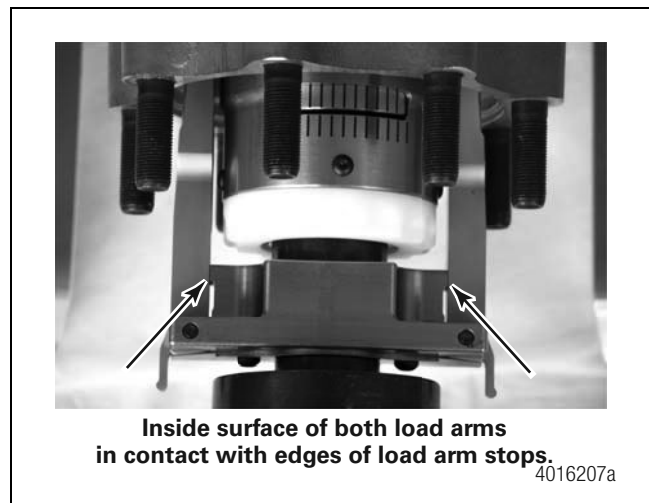
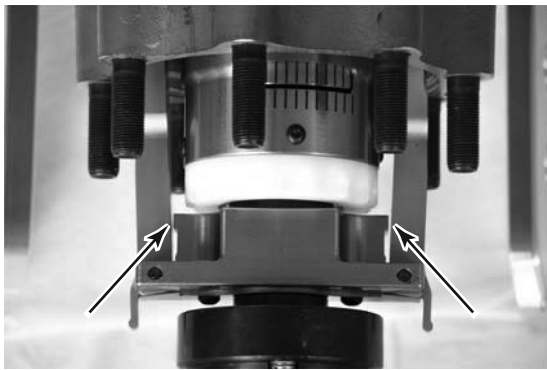

Figure 5



Inside surface of both load arms NOT in contact with edges of load arm stops.

4016209a

Figure 6

CAUTION

Do NOT over-tighten the yellow T-handle to the point that the needle pointer exceeds the maximum value shown on the gauge. Allow the needle pointer to catch up while slowly tightening the T-handle.

4. Seat the bearing rollers by SLOWLY tightening the T-handle clockwise.

Turn the T-handle to load the bearings until the needle pointer on the Doctor Preload gauge reaches the green "Roll-in Zone". Holding the Gauge Guard Handle firmly with one hand, use the other hand to spin the hub at least three full turns in any one direction to seat the bearing rollers. The load may drop slightly when rolling in the bearings – this is normal. If the needle pointer drops out of the "Roll-in Zone", tighten the T-handle until it returns to the "Roll-in Zone" and spin the hub again. Repeat until the needle pointer stays in the "Roll-in Zone." **Do NOT spin the hub again after this step.** If the hub is spun again, remove Doctor Preload and start over by fully seating the hub as described in "Prepare the Wheel End for Bearing Adjustment". **Do NOT tighten the Temper-Loc nut against the bearing while the needle pointer is in the green "Roll-In Zone".** Figure 7.



4016210a

Figure 7

5. Set the bearings as follows. Loosen the T-handle, turning it counterclockwise slowly until the needle pointer reaches the 1,000 lbs force hash mark. Do NOT go past the set point; if the set point is overshoot, go back to Step 2 and repeat in order to seat the bearing rollers. Figure 8.



4016211a

Figure 8

6. Lock in the bearing setting as follows. Push the Nut Turner towards the hub to engage the Temper-Loc nut. Rotate the Nut Turner clockwise until the nut backface first makes light contact with the bearing face. Make sure that the Window on the Nut Turner is located at the top of the tool. If it is not, disengage the Nut Turner from the nut and rotate the Nut Turner until the Window is in the correct position. Standing directly in front of the Doctor Preload tool, look towards the Nut Turner Window to determine if the two sets of hash marks are aligned. If the hash marks are aligned, this step is completed. If the two sets of hash marks are NOT aligned, turn **BACK** the Nut Turner very slightly until the very next set of hash marks line up. Figure 9 and Figure 10.

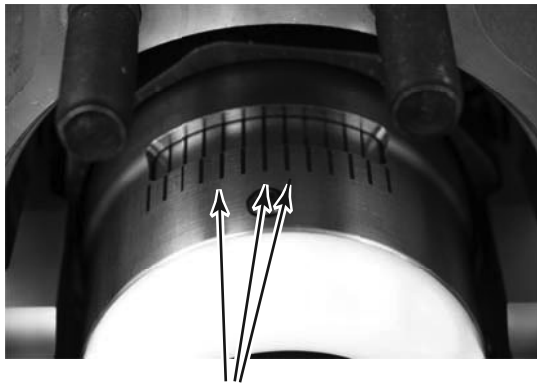

The two sets of hash marks are aligned.

4016212a

Figure 9

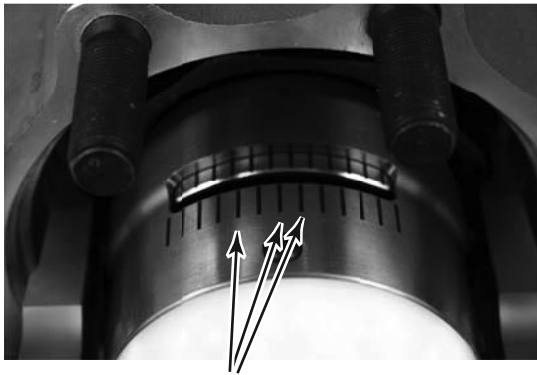

The two sets of hash marks are NOT aligned.

4016213a

Figure 10

NOTE: The hash marks are positioned so that, when the user is standing in front of the tool and looking in a “direct line of sight” along one set of hash marks to the other set of hash marks, lining up the hash marks will ensure that the hash marks are aligned all around the circumference of the Circular KeyFinder. Due to normal visual distortion, if the user looks to the left or to the right along the Circular KeyFinder, it will appear that the hash marks are out of alignment. This can be seen in Figure 9.

7. Remove the Doctor Preload tool from the spindle. Completely loosen the T-handle by turning it counterclockwise until the load shown on the gauge drops to ZERO and the threads on the shaft are completely covered. Hold the Gauge Guard Handle to support the weight of the tool, and then loosen the star-handle, turning it counterclockwise. When the tool is unattached from the spindle, gently rotate the Doctor Preload tool until the two load arm tips are positioned over two flats of the nut, and pull straight back and the load arms will slide back around the nut.

8. Install the retainer ring. First, install the EasyView® center tab of the retainer ring in the Temper-Loc nut, engaging the key in the keyway at the same time. Figure 11. Push in on each end finger tab, one at a time, to fit each tab into the nut groove. Figure 12.

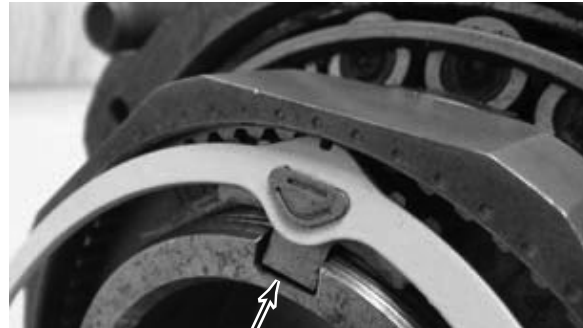

Retainer tab entering groove in nut.

4016214a

Figure 11



Retainer tab inserted correctly in nut.

4016215a

Figure 12

Inspect the Final Assembly of the Temper-Loc Nut

WARNING

You must inspect the retainer ring in the nut to ensure it has been correctly installed. Failure to inspect the installation thoroughly could result in component failure and serious personal injury.

Ensure that there is a yellow retainer ring inserted in the nut. Check that all three EasyView tabs and locking teeth of the key are fully seated in the nut for safe installation. The EasyView notches of all three tabs must be completely hidden in the groove of the nut.



Meritor Heavy Vehicle Systems, LLC
7975 Dixie Highway
Florence, KY 41042 USA
US 888-725-9355
Canada 800-387-3889
meritorpartsonline.com

Information contained in this publication was in effect at the time the publication was approved for printing and is subject to change without notice or liability. Meritor Heavy Vehicle Systems, LLC, reserves the right to revise the information presented or to discontinue the production of parts described at any time.

Copyright 2020
Meritor, Inc.
All Rights Reserved

Printed in USA

TP-1991
Issued 04-20
(16579)