

AIR DISC BRAKE

EX+™ LS

Tested. Proven. Trusted.

Specifically engineered for linehaul and trailer applications, Meritor® EX+ LS air disc brakes are light in weight and heavy on performance. Built on proven and reliable EX+ architecture, these components have been comprehensively tested to exceed customer needs.

EX+ LS Advantages

- Large piston diameter controls taper wear to extend pad life
- Adjuster mechanism based on proven EX+ brake system
- Standard with N Type friction, 2025 reduced copper-compliant brake pads
- Piston seal is protected from heat exposure and debris for longer brake life
- Common pad and service items for truck and trailer applications



TRUCK & TRAILER



Maximize performance with our lightest-ever North American air disc brakes

The industry-leading safety and performance you rely on has been elevated to an entirely new standard. Lighter and smarter, with over one million miles of field testing, it is well ahead of the curve for linehaul and trailer applications.

Primary design advantages

Integrated piston/pusher function eliminates play and distributes force evenly while securing pads in place, despite rotor force and direction

Large piston diameter is 2x the size of leading competitive single piston brakes and provides taper wear control to extend pad life

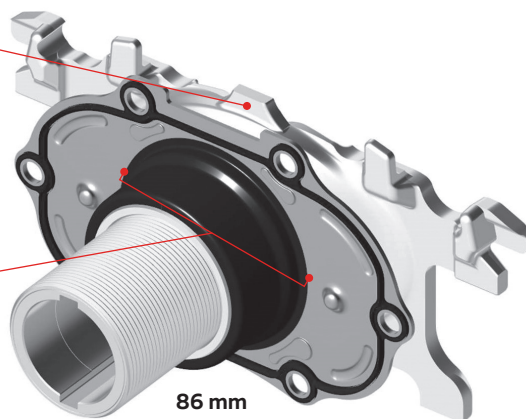

Advanced seal protection

Heat and debris are the primary threats to the piston boot. EX+ LS protects this boot until the pads are significantly worn.

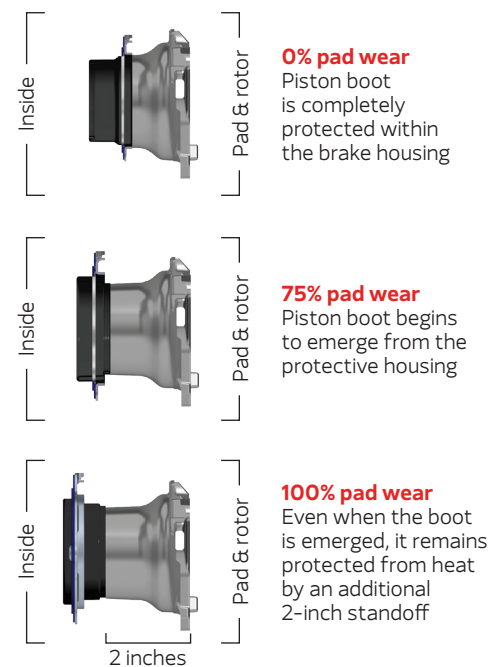

Meritor® EX+ LS comes standard with N Type friction, providing more consistent torque output, longer pad life and 2025 reduced-copper compliance.

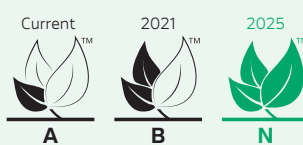

Optional features

Positive pad retraction (PPR)	Electronic pad wear warning indicator	Pad + rotor shields
Ensures running clearance is at the friction couple, extending pad life and fuel economy	Pad wear sensing immediately communicates when pads have worn to the replacement point	Provide added protection from contaminants entering the brake

Unmatched customer support

Every Meritor EX+ LS air disc brake is backed by unsurpassed service and support, with DriveForce™ – our North American sales and service organization – and the OnTrac™ technical support center available to assist customers with solutions before, during and after the sale. For more information, call **866-668-7221 (OnTrac1)** or visit Support → CDBS Customer Support on **cummins.com**.



Cummins Inc.
Box 3005
Columbus, IN 47202-3005
U.S.A.

cummins.com

SP-1998
Bulletin 6449488 Produced in U.S.A. Rev. 9/24
©2024 Meritor, Inc.