

# MERITOR® CLEARANCE-SENSING AUTOMATIC SLACK ADJUSTERS



**MERITOR**



# AUTOMATIC SLACK ADJUSTER CHOICES FROM MERITOR.

## Models To Fit Every Need.

The Meritor Clearance-Sensing ASA is available in three models to meet a variety of application requirements. The Clearance-Sensing ASA can be used as a direct replacement for an existing competitive slack for truck, tractor and trailer applications and is identical in fit, form and function.

The Self-Setting (S-ASA), the Premium and the Standard models makeup the Meritor Clearance-Sensing lineup and each offers distinct advantages based on a fleet or owner-operator's specific needs.

### Self-Setting ASA

The S-ASA is easier to fit because it offers a greater degree of freedom in positioning the control arm due to its ability to self-adjust. The control arm can be fixed to the anchor bracket at any point within its arc of rotation (-16° to +130°). This allows for easier, more efficient installation and solves adjustment problems.

### Premium and Standard ASAs

The Meritor Premium and Standard models are also easy to use and offer simple, reliable installation. The machined-in notch creates a clear reference point for installation alignment. The control arm visual indicator requires proper alignment during installation to ensure accurate brake adjustment. The Premium and Standard clearance-sensing models feature:

- Easily accessible adjustment hex with no locking pawls to remove or disengage; simplifies adjustment during installation and brake lining replacement
- Built-in visual indicator to allow for quick verification of proper installation; no cumbersome templates

Available for a wide range of brake specifications, the Meritor Clearance-Sensing ASA lineup covers 12.25-inch to 18-inch brakes. This includes the most popular 16.5-inch brakes for truck, trailer, severe-duty applications and more.

## Meritor is the only supplier that can offer both stroke- and clearance-sensing automatic slack adjusters.

	Meritor Genuine ASA	Meritor ASA	Haldex	Gunite	Bendix	STEMCO
<b>System Sensing Design</b>	Stroke	Clearance	Clearance	Clearance	Clearance	Clearance
<b>Adjustment Stroke</b>	Return	Return	Return	Apply	Apply	Return
<b>Actuation Type</b>	Lift Rod	External Bracket	External Bracket	Lift Rod	Lift Rod	Lift Rod
<b>Packaging</b>	Handed & Non-Handed	Handed & Non-Handed	Handed & Non-Handed	Non-Handed	Non-Handed	Non-Handed
<b>Installation Guide</b>	Hand-Held Locator	Bolt-On Slotted Bracket	Bolt-On Slotted Bracket	Hand-Held Locator	None Provided	Rigid Hands-Free Locator
<b>Manual Adjustment</b>	Request Pawl Removal/Pull Out	Low Rotation Force	Low Rotation Force	High Rotation Force	Moderate Rotation Force	Low Rotation Force
<b>Weight</b>	6 lbs. 13 Oz.	7 lbs. 2 Oz.	7 lbs. 2 Oz.	7 lbs. 1 Oz.	7 lbs. 5 Oz.	7 lbs. 1 Oz.

\* See publication SP-15102 for information on the Meritor Stroke-Sensing ASA offering.



## You Asked. We Listened.

You asked for more options to fit every budget and Meritor listened. The Meritor Premium and Standard Clearance Sensing ASAs offer end-users more options when choosing the right ASA without sacrificing quality or performance.

The **Premium** model is the go-to unit with decades of proven performance. Higher quality materials and supplemental, proprietary post-processing steps provide superior service life. The design is ideal for fleets and

vehicle operators that want a premium product with premium benefits for maximum uptime.

For end-users with a limited budget, the **Standard** model is the perfect choice. To carry the Meritor name, the Standard model had to meet Meritor's requirements for quality and durability. The design speaks for itself. Featuring many of the same components as the Premium model, the Standard ASA has minimal design differences, but maximum benefits.

Meritor Clearance-Sensing Slacks						
Material Comparison						
Type	Body/Housing	Worm Shaft	Worm Wheel	Gaskets	Rack	Control Disc
Premium	High-grade material Housing is post-treated for optimum wear resistance	High-grade base material with heat-treating and proprietary post-processing of conical clutch serrations ensure longer strength and life	High-grade, wear-resistant material	High-grade material	High-grade sinter material	High-grade sinter material
Standard	High-grade material Housing is post-treated for optimum wear resistance	High-grade base material with heat-treating and proprietary post-processing ensure strength and life  Slight variation in post-processing without sacrificing wear characteristics	Standard-grade, wear-resistant material  Utilizes different base material while post-processing steps ensure strength and life are not compromised	Standard-grade material  Offers same functionality through more cost-efficient materials	High-grade sinter material	High-grade sinter material

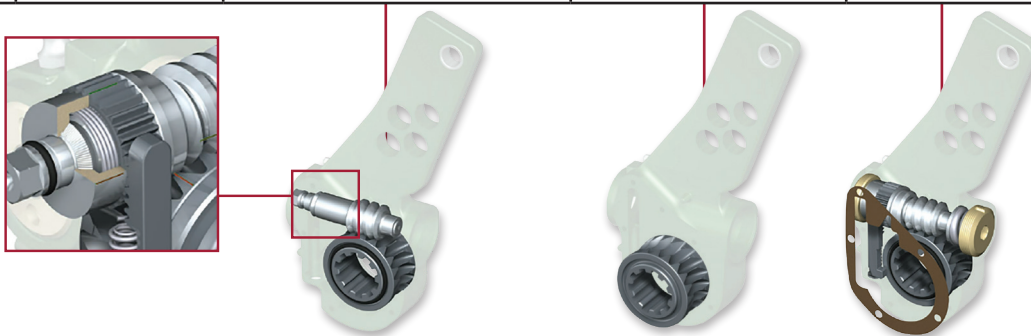

## Warranties That Offer Peace of Mind.

Meritor warrants the Meritor Clearance-Sensing Automatic Slack Adjuster to be free of faults arising from either imperfect material or workmanship for the period and/or mileage (whichever is greater) as indicated below:

Type	Application	Meritor Part Numbers	Warranty Period/Distance
Premium	Linehaul	M807000 thru M807508	6-Years/1,000,000-Miles
Self-Setting	Linehaul	M808000 thru M808508	6-Years/1,000,000-Miles
Standard	Linehaul	R806000A thru M806508A	2-Years/200,000-Miles
Premium	Intercity Transit	M807521 thru M807587	2-Years/200,000-Miles (or 2 Relines)
Premium	Severe-Duty	M807000 thru M807508 M808000 thru M808508	2-Years/100,000-Miles
Premium	City Transit	M807521 thru M807587	1-Year/100,000-Miles (or 2 Relines)

Please note, the automatic slack adjuster cannot compensate for other deficiencies within the braking system. Before returning a unit, check for:

- Proper installation
- Binding camshafts
- Defective brake chambers
- Loose wheel bearings
- Worn or missing brake return springs
- Worn camshaft bushings and bearings

## Service and Support That Make Life Easier.

The Meritor sales team has the product knowledge and expertise to help find the Meritor ASA that meets your needs. Call our Customer Care team at 888-725-9355 (in Canada, call 800-387-3889) for the total service and support you deserve.

Trademarks, brands, and names depicted herein are the property of Meritor, Inc. or its affiliates.



Meritor Heavy Vehicle Systems, LLC  
7975 Dixie Highway  
Florence, Kentucky 41042 USA

U.S. 888-725-9355  
Canada 800-387-3889  
MeritorPartsXpress.com  
meritor.com

©2018 Meritor, Inc.  
Litho in USA, SP-1639  
Issued 06-18 (47865/11900)