



Recommended Service Guidelines for the Meritor MTC-4208, -4210 and -4213 Transfer Case

How to Obtain Additional Lubrication and Maintenance Information

Refer to Maintenance Manual 1, Preventive Maintenance and Lubrication; Maintenance Manual MM-0146, Transfer Cases MTC-4208, -4210 and -4213; Technical Bulletin TP-90114, Transmission Lubricant Specifications; and TP-9579, Driver Instruction Kit. To obtain these publications, visit Literature on Demand at meritor.com.

Inspection

Meritor MTC-4208, -4210 and -4213 Transfer Case Inspection

CAUTION

Do not operate the transfer case if the oil level is below the bottom of the fill hole, which may be an indication that the transfer case is leaking. Damage to components can result. If the transfer case is leaking, repair the leak. Adjust the oil level before returning the transfer case to service.

When servicing the transfer case, add the specified lubricant until the oil level is even with the fill hole. Do not overfill the transfer case, which can cause the transfer case to overheat. Damage to components can result.

Meritor does not approve petroleum-based and multiviscosity oil. Do not install API GL-5 oils, which contain extreme-pressure (EP) additives. These additives can form sludge at normal operating temperatures. Damage to components can result. Use only SAE Grade 50W synthetic oil in the transfer case.

Visually inspect the Meritor MTC-4208, -4210 and -4213 transfer cases daily for any leaks. The oil level should be inspected every 1,000 miles (1069 km), 100 hours or every month, whichever comes first. In addition, the transfer case should be inspected for leaks and the correct oil level before and after extended time high speed road trips. Inspect the following areas.

- Cooler lines and fittings
- Seals
- Breather
- Fill and drain plugs
- Pump inlet tube and fittings
- Gaskets and shims
- During the inspection visually check to ensure the transfer case oil level is to the bottom of the oil fill hole.

Operation	Frequency
Inspect for oil leaks	Daily
Check oil level	1,000 miles (1609 km), 100 hours or every month, whichever occurs first
Check oil level	Before and after extended time high speed road trips
Initial oil change	2,500 miles (4000 km) or 125 hours, whichever occurs first
Synthetic oil change	Every 25,000 miles (40 000 km), 1,250 hours or every 12 months, whichever occurs first

Meritor-approved full synthetic oil for Meritor manual transmissions is also approved for Meritor transfer cases. Refer to publication TP-90114 for a list of approved distributors.

Towing Procedures

CAUTION

Follow towing procedures recommended by Meritor to prevent internal damage to the transfer case.

Meritor recommends that you use one of the two methods below when towing a vehicle equipped with an MTC-4208, -4210 or -4213 transfer case to prevent damage to the transfer case.

For complete towing information and instructions on shaft removal, refer to Technical Bulletin TP-9579.

Method 1

Remove both axle shafts from the axles that will remain on the road when the vehicle is transported.

Method 2

Remove the drive shafts from axles that contact the ground.

Seal Replacement

Meritor has released the multiple-lip seal (MLS) for use in the INPUT POSITION ONLY on the MTC-4208, -4210 and -4213 transfer cases. The multiple-lip seal is compatible with the current input shaft seal and can be used in service. Refer to Figure 1 for the INPUT position and front OUTPUT position. Refer to Figure 2 for the MTC-4208 and -4210 rear OUTPUT position. Refer to Figure 3 for the MTC-4213 rear OUTPUT position.

Transfer Case Model	Seal Position	Seal Service Part Number	Previous Seal Part Number	Seal Driver	Sleeve Driver
MTC-4208, -4210 and -4213	Input Shaft	A1-1205X2728	A 1205R2592	2728T1	2728T2
MTC-4208 and -4210	Forward and Rear Output	R945007	A 1205R2592	KIT 4454	NA
MTC-4213	Forward Output	R945007	A 1205R2592	KIT 4454	NA
MTC-4213	Rear Output	R945010	A 1205Q2591	KIT 4454	NA
MTC-4208 and -4210	PTO Seal	R945008	A 1205P2590	KIT 4454	NA

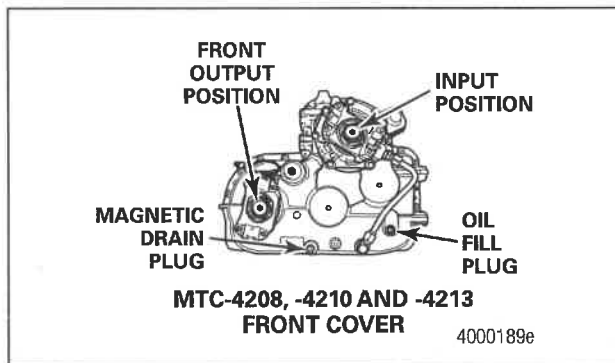

Figure 1

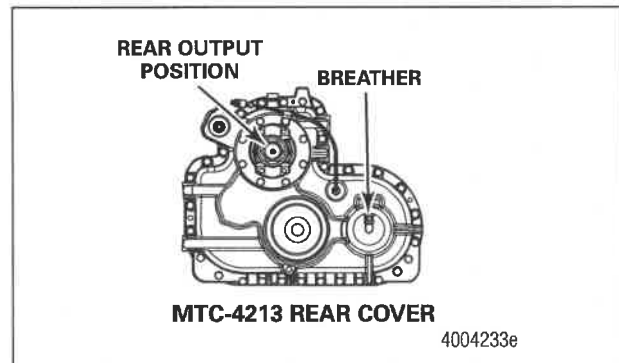

Figure 3

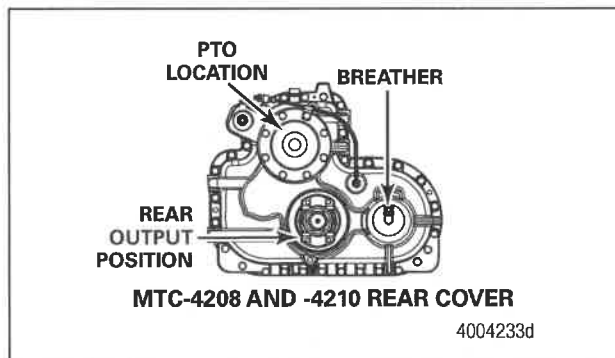

Figure 2

⚠ CAUTION

Only install the Meritor multi-lip unidirectional seal at the input position from the transmission in an MTC-4208, -4210 or -4213 transfer case. If you install the multi-lip seal in either the rear output position or forward output position on these transfer cases, loss of lubricant and damage to components can occur.

The multiple-lip seal must be serviced with the seal and sleeve. The service part number provides both when required. Check your application carefully before installing the multiple-lip seal.

Special Tools and Installation Procedure

Refer to Maintenance Manual MM-0146 for the correct seal installation procedure. To obtain these sleeves, seals and drivers, call Meritor's Commercial Vehicle Aftermarket at 888-725-9355.



Meritor Heavy Vehicle Systems, LLC
2135 West Maple Road
Troy, MI 48084 USA
866-OnTrac1 (668-7221)
meritor.com

Information contained in this publication was in effect at the time the publication was approved for printing and is subject to change without notice or liability. Meritor Heavy Vehicle Systems, LLC, reserves the right to revise the information presented or to discontinue the production of parts described at any time.

Copyright 2008
Meritor, Inc.
All Rights Reserved

Printed in USA

TP-0636
Revised 09-08
(16579)



Installing a Multiple-Lip Seal (MLS) onto Meritor Single and Tandem Drive Axles Using Kit 4463

140, 160, 180 and M-14X Series Single Drive Axles
140, 160, 180 and 380 Series Tandem Drive Axles
Does Not Apply to Meritor Front Drive Steer Axles, Other
Drive Axles or Transfer Cases Not Listed in This Bulletin

Hazard Alert Messages

Read and observe all Warning and Caution hazard alert messages in this publication. They provide information that can help prevent serious personal injury, damage to components, or both.

How to Obtain Additional Maintenance, Service and Product Information

Refer to the Multiple-Lip Seal (MLS) Installation CD (order TP-0531); Maintenance Manual 5A, Single-Reduction Rear Differential Carriers: Single Rear Drive Axles, Rear-Rear Tandem Drive Axles and Front Drive Steer Axles; Maintenance Manual 5L, Single-Reduction Forward Differential Carriers on Tandem and Tridem Axles; Maintenance Manual MM-0990, Amboid Rear Differential Carrier: Rear/Rear Carrier on MT-40-14X Series Tandem Drive Axles; and Maintenance Manual MM-0146, Transfer Cases. To obtain these publications, visit Literature on Demand at meritor.com.

How to Obtain Kits

To obtain Kit 4463, call Meritor's Commercial Vehicle Aftermarket at 888-725-9355.

Important Information

This technical bulletin provides the recommended procedure for installing Meritor multiple-lip seals (MLS) on Meritor 140, 160, 180 and M-14X single and 140, 160, 180 and 380 tandem drive axles as well as MTC Series transfer cases at the input position only. These instructions do not apply to front drive steer axles, other transfer cases or other drive axles not listed in this publication.

Meritor multiple-lip seals feature a separable sleeve installed onto the yokes at the tandem forward-rear input, forward-rear output and transfer case positions. No sleeve is used on the rear-rear input.

Installation of the new seals requires a set of four seal drivers and two sleeve drivers. Refer to the following table for part numbers.

Table A: Driver and Sleeve Part Numbers

Axle Model and Position	Seal Service Part Number	Seal Drivers	Sleeve Drivers
140, 160, 180 and 380 Forward-Rear Unit Input (FUI)	A1-1205X2728	2728T1	2728T2
140 and 160 Forward-Rear Unit Output (FUO)	A1-1205Y2729	2729T1	2729T2
140, M-14X Rear-Rear Unit Input (RUI) — 2.47-7.17 Ratios	A1-1205Z2730	2730T1	Not Required — Sleeve is unitized
M-14X Rear-Rear Unit Input (RUI) — 2.28 Ratio	A1-1205Z2730	2730T1A	Not Required — Sleeve is unitized
160 and 180 Rear-Rear Unit Input (RUI)	A1-1205A2731	2731T1	Not Required — Sleeve is unitized
MTC 4208/4210/4213 Input Shaft Only (Transfer Case)	A1-1205X2728	2728T1	2728T2

NOTE: The X in the third position represents all carrier models in the series. For example, 14X applies to carrier models 143, 145, etc.

Forward input and output seals must be serviced with the seal and sleeve. The service part number provides both when required. Check your application carefully before installing the multiple-lip seal.

Special Tools

There are six new installation drivers required for replacement of the multiple-lip axle yoke seals. Figure 1. To obtain these sleeves, seals and drivers, call Meritor's Commercial Vehicle Aftermarket at 888-725-9355.

- A sleeve driver and seal driver for the forward-rear input or transfer case input
- A sleeve driver and seal driver for the forward-rear output
- Two model specific seal drivers for the rear-rear input

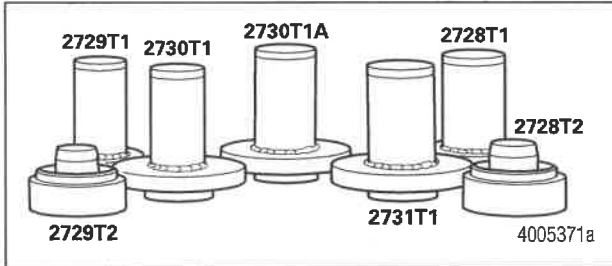

Figure 1

Removal

⚠ WARNING

To prevent serious eye injury, always wear safe eye protection when you perform vehicle maintenance or service.

Park the vehicle on a level surface. Block the wheels to prevent the vehicle from moving. Support the vehicle with safety stands. Do not work under a vehicle supported only by jacks. Jacks can slip and fall over. Serious personal injury and damage to components can result.

⚠ CAUTION

On a rear-rear input, if you partially or fully install a yoke and then remove it for any reason, remove, discard and replace the seal with a new seal. If a seal or sleeve is removed after partial or full installation, discard the seal or sleeve and replace it with a new seal or sleeve. Damage to components can result.

1. Wear safe eye protection.
2. Park the vehicle on a level surface. Set the parking brake. Block the wheels to prevent the vehicle from moving.
3. Use a jack to raise the vehicle so that the wheels to be serviced are off the ground. Support the vehicle with safety stands.
4. Disconnect the drive shafts.

5. Attach a flange bar or place a yoke bar over the input or output yoke to hold the yoke or flange while you remove the nut. Always use a flange or yoke bar during removal and installation of the flange yoke nut to prevent damage to the gearing. Figure 2.

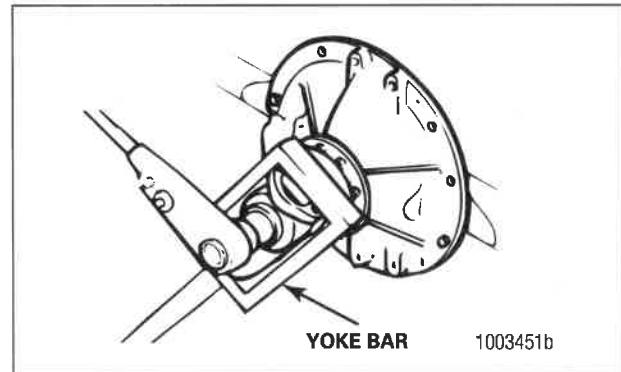

Figure 2

⚠ WARNING

Use a puller tool to remove the yoke or flange from the shaft. Do not use a hammer or mallet, which can damage components and cause vibration in the driveline. If this occurs, the driveline can separate from the vehicle during operation. Serious personal injury and damage to components can result.

6. Remove the yoke nut and washer. Use a puller tool to remove the yoke or flange from the shaft. Do not use a hammer or mallet, which can damage components. Figure 3.

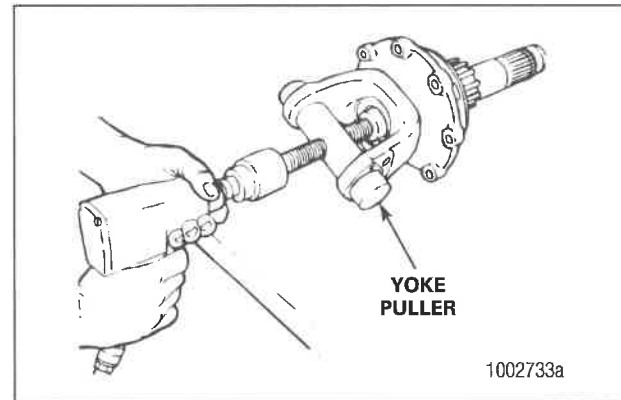

Figure 3

⚠ CAUTION

On axles that have the bolt-on deflector on the forward-rear output shaft bearing cage, the deflector must be removed and discarded. The new forward output sleeve will not assemble correctly to the new output seal with the bolt-on deflector in place. Remove the deflector from the output shaft bearing cage and reassemble the output cage hex-head capscrews and washers according to the appropriate maintenance manual instructions. Damage to components can result.

7. Carefully remove the pinion seal from the yoke or carrier. Do not damage the seal bore when you remove the seal. Do not allow dirt or grease to contaminate the seal bore or adjacent bearings.
8. If a seal sleeve is installed onto a yoke, remove the sleeve using a bearing puller. Do not reuse the seal sleeves.
9. Inspect the yoke seal area for damage that could cause lubricant leaks after you install the seal. Use emery paper or an equivalent product to remove scratches, nicks or burrs only.

Installation

⚠ WARNING

Solvent cleaners can be flammable, poisonous and cause burns. Examples of solvent cleaners are carbon tetrachloride, and emulsion-type and petroleum-base cleaners. Read the manufacturer's instructions before using a solvent cleaner, then carefully follow the instructions. Also follow the procedures below.

- Wear safe eye protection.
- Wear clothing that protects your skin.
- Work in a well-ventilated area.
- Do not use gasoline, or solvents that contain gasoline. Gasoline can explode.
- You must use hot solution tanks or alkaline solutions correctly. Read the manufacturer's instructions before using hot solution tanks and alkaline solutions. Then carefully follow the instructions.

1. Clean the ground and polished surface of the yoke journal using a clean shop towel and a safe cleaning solvent. Do not use abrasive cleaners, towels or scrubbers to clean the yoke or flange surface. Do not use gasoline.
2. Inspect the yoke seal area for damage that could cause lubricant leaks after you install the seal. Use emery paper or an equivalent product to remove scratches, nicks or burrs only.

3. Install the deflector, if equipped, onto the yoke. You must install the deflector before you install the sleeve into the yoke. Figure 4.

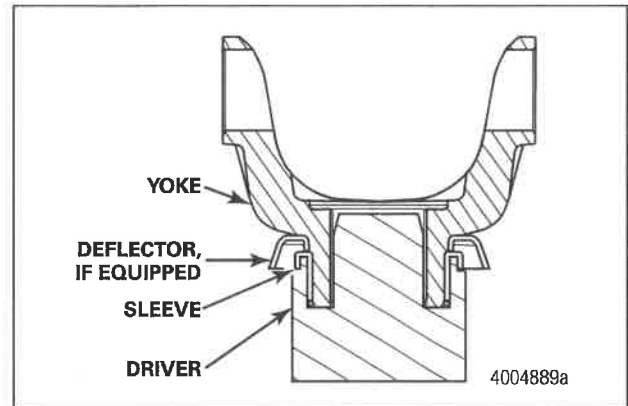

Figure 4

⚠ WARNING

Observe all warnings and cautions provided by the press manufacturer to avoid damage to components and serious personal injury.

Do not hit steel parts with a steel hammer. Pieces of a part can break off. Serious personal injury and damage to components can result.

4. Apply a light coat of axle oil to the yoke seal journal. Position the sleeve into the forward-rear axle output yoke sleeve driver. Do not touch the greased areas of the sleeve. The sleeve must be kept clean prior to assembly into the seal. Use an arbor press and the appropriate driver to install the sleeve into the yoke. Verify that the sleeve is fully-seated in the yoke to prevent damage to components. Figure 5.

The yoke must be fully pressed into the sleeve driver until the end of the yoke bottoms out in the sleeve driver. This will correctly position the sleeve on the yoke. When correctly seated, the forward-rear output sleeve is positioned 0.200-inch \pm 0.030-inch (5 mm \pm 0.76 mm) from the end of the yoke. Figure 6.

- If you do not have a press: Position the yoke on a five-inch (127 mm) spacer on a workbench. Use a dead-blow hammer and the appropriate driver to install the sleeve into the yoke. Figure 7.

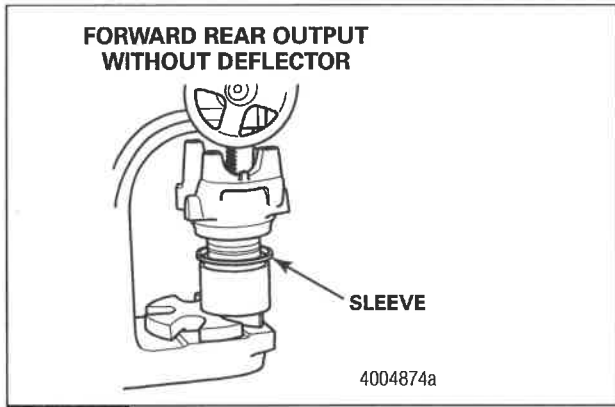

Figure 5

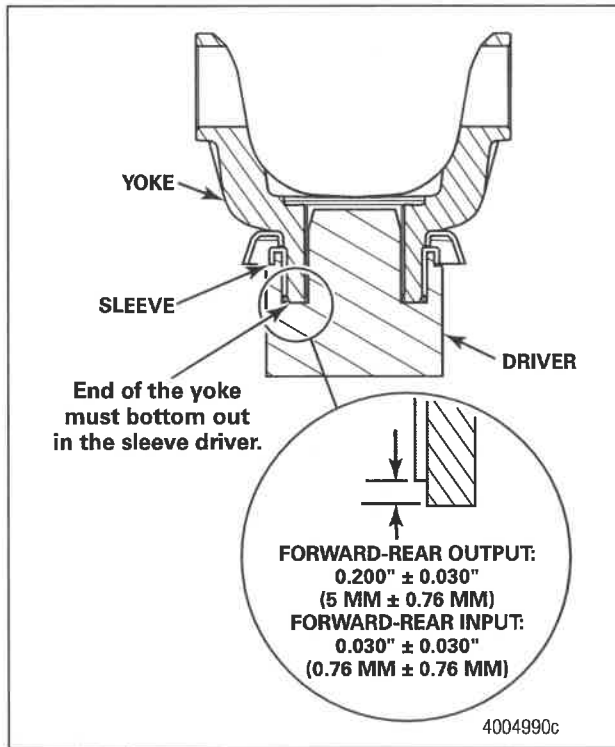

Figure 6

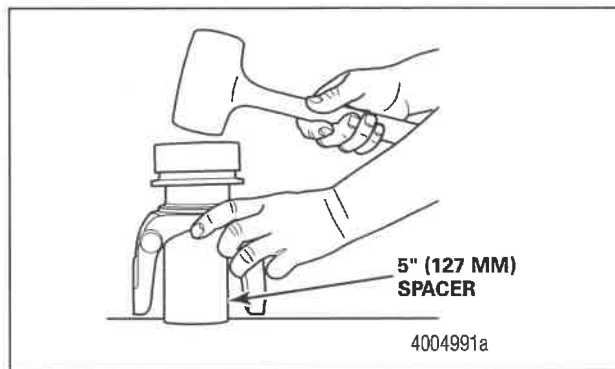

Figure 7

- Apply a light coat of axle oil to the yoke seal journal. Position the sleeve into the forward-rear axle input yoke sleeve driver. Do not touch the greased areas of the sleeve. The sleeve must be kept clean prior to assembly into the seal. Use an arbor press and the appropriate driver to install the sleeve into the yoke. Verify that the sleeve is fully-seated in the yoke. Figure 8.

The yoke must be fully pressed into the sleeve driver until the end of the yoke bottoms out in the sleeve driver. This will correctly position the sleeve on the yoke. When correctly seated, the forward-rear input sleeve is positioned 0.030-inch \pm 0.030-inch (0.76 mm \pm 0.76 mm) from the end of the yoke. Figure 6.

- If you do not have a press:** Position the yoke on a five-inch (127 mm) spacer on a workbench. Use a dead-blow hammer and the appropriate driver to install the sleeve into the yoke. Figure 7.

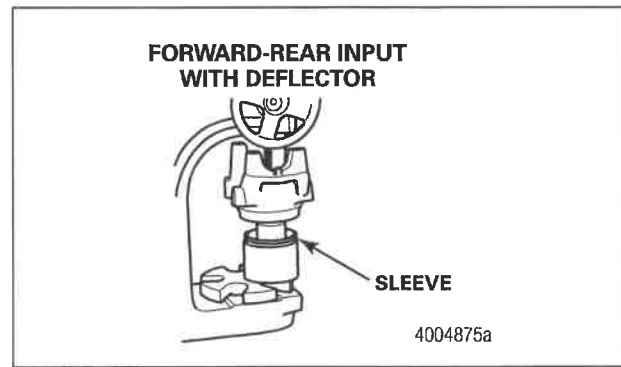

Figure 8

⚠ CAUTION

Hold the sleeve and seal only on the outer diameter. Do not touch the greased inner diameter of the seal and the greased area of the sleeve. This can contaminate the seal and cause a leak between the shaft and the seal. Damage to components can result.

- Install the forward-rear axle input seal. Hold the sleeve and seal only on the outer diameter. Position the seal into the seal driver and align it with the forward-rear axle input bearing cage. Do not touch the lips in the inner diameter of the seal. Use a dead-blow hammer and the appropriate driver to install the seal into the bearing cage. Figure 9.

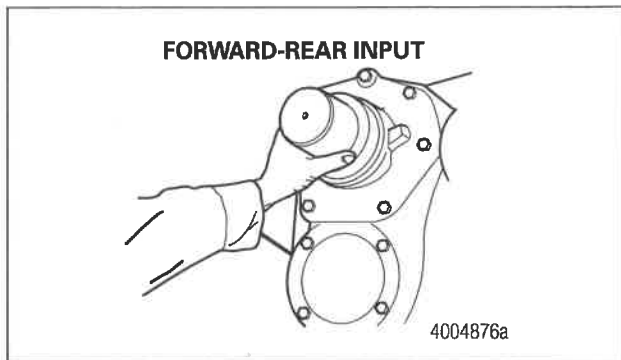

Figure 9

CAUTION

On axles that have the bolt-on deflector on the forward-rear output shaft bearing cage, the deflector must be removed and discarded. The new forward output sleeve will not assemble correctly to the new output seal with the bolt-on deflector in place. Remove the deflector from the output shaft bearing cage and reassemble the output cage hex-head capscrews and washers according to the appropriate maintenance manual instructions. Damage to components can result.

7. Install the forward-rear axle output seal. Hold the sleeve and seal only on the outer diameter. Position the seal onto the seal driver and align it with the forward-rear axle output shaft. Do not touch the lips in the inner diameter of the seal. Use a dead-blow hammer and the appropriate driver to install the seal onto the output shaft. Figure 10.

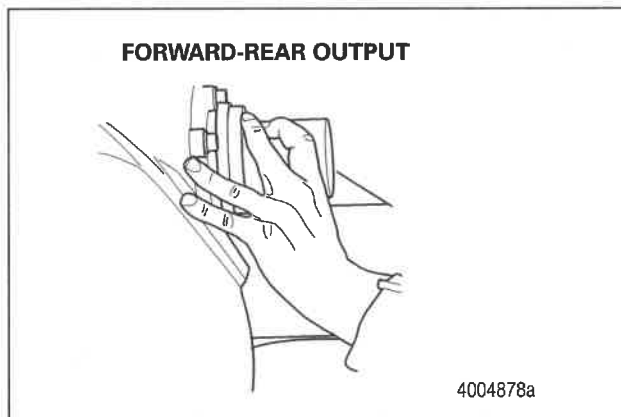

Figure 10

8. Install the rear-rear axle input seal. Hold the seal only on the outer diameter. Position the seal into the seal driver and align it with the rear-rear axle input bearing cage. Use a dead-blow hammer and the appropriate driver to install the seal into the bearing cage. Figure 11.

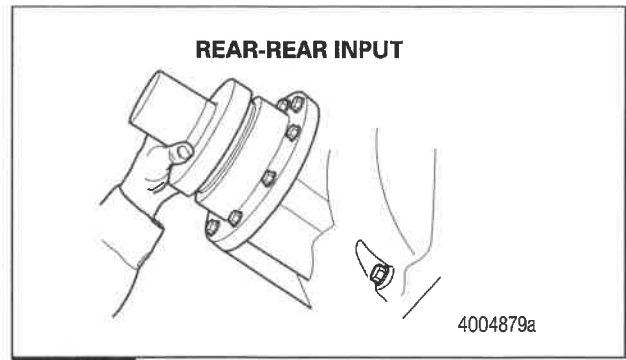

Figure 11

9. Use a feeler gauge to check the seal gap at all three axle positions. The seal is correctly installed if the gap is less than 0.005-inch (0.127 mm) around the circumference of the seal flange. Figure 12.

- If the gap is more than 0.005-inch (0.127 mm): Use a dead-blow hammer and the appropriate driver to completely install the seal.

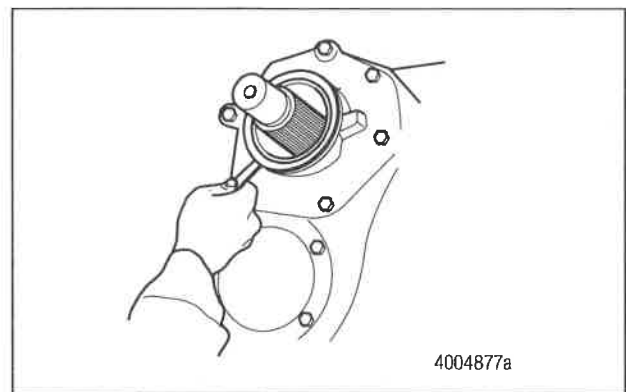

Figure 12

10. Apply a light coat of axle oil to the yoke seal journal. Install the yokes and connect the drive shafts. Refer to the manuals specified in this bulletin for the correct procedures.
11. Apply a light coat of axle oil to the yoke seal journal. Position the sleeve into the transfer case input yoke sleeve driver. Do not touch the greased areas of the sleeve. The sleeve must be kept clean prior to assembly into the seal. Use an arbor press and the appropriate driver to install the sleeve into the yoke. Verify that the sleeve is fully-seated in the yoke.

The yoke must be fully pressed into the sleeve driver until the end of the yoke bottoms out in the sleeve driver. This will correctly position the sleeve on the yoke. When correctly seated, the transfer case input sleeve is positioned 0.030-inch \pm 0.030-inch (0.76 mm \pm 0.76 mm) from the end of the yoke. Figure 13.

- **If you do not have a press:** Position the yoke on a five-inch (127 mm) spacer on a workbench. Use a dead-blow hammer and the appropriate driver to install the sleeve into the yoke.

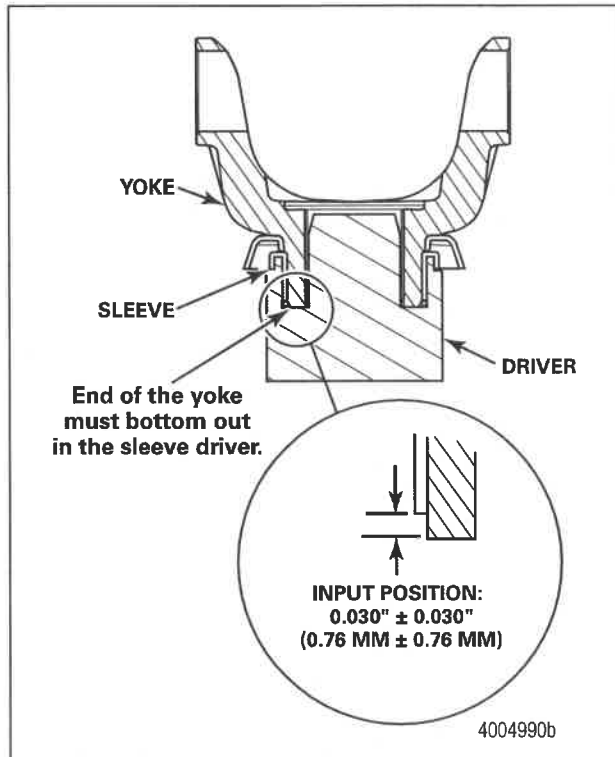

Figure 13

⚠ CAUTION

Hold the sleeve and seal only on the outer diameter. Do not touch the greased inner diameter of the seal and the greased area of the sleeve. This can contaminate the seal and cause a leak between the shaft and the seal. Damage to components can result.

12. Install the transfer case input seal. Hold the sleeve and seal only on the outer diameter. Position the seal into the seal driver and align it with the transfer case input bearing cage. Do not touch the lips in the inner diameter of the seal. Use a dead-blow hammer and the appropriate driver to install the seal into the bearing cage. Figure 14.

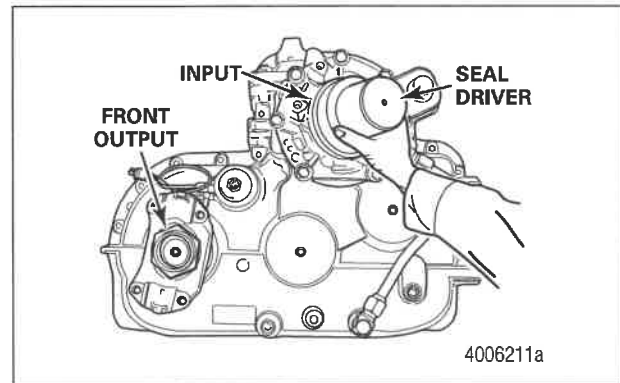

Figure 14

13. Use a feeler gauge to check the seal gap at the transfer case input position. The seal is correctly installed if the gap is less than 0.005-inch (0.127 mm) around the circumference of the seal flange. Figure 12.
 - **If the gap is more than 0.005-inch (0.127 mm):** Use a dead-blow hammer and the appropriate driver to completely install the seal.
14. Apply a light coat of axle oil to the yoke seal journal. Install the yoke and connect the drive shaft. Refer to the manuals specified in this bulletin for the correct procedures.



Meritor Heavy Vehicle Systems, LLC
2135 West Maple Road
Troy, MI 48084 USA
866-OnTrac1 (668-7221)
meritor.com

Information contained in this publication was in effect at the time the publication was approved for printing and is subject to change without notice or liability. Meritor Heavy Vehicle Systems, LLC, reserves the right to revise the information presented or to discontinue the production of parts described at any time.

Copyright 2015
Meritor, Inc.
All Rights Reserved

Printed in USA

TP-0446
Revised 10-15
(16579)

MULTIPLE-LIP SEAL (MLS) PART NUMBER AND DRIVER INFORMATION

NOTE: The X in the third position represents all carrier models in the series. For example, 14X applies to carrier models 143, 145, etc.

Axle Model and Position	Seal Service Part Number	Seal Drivers	Sleeve Drivers
14X/16X/18X/38X Forward-Rear Unit Input (FUI)	A1-1205X2728	2728T1	2728T2
14X/16X Forward-Rear Unit Output (FUO)	A1-1205Y2729	2729T1	2729T2
14X Rear-Rear Unit Input (RUI) — 2.47-7.17 Ratios	A1-1205Z2730	2730T1	Not Required — Sleeve is unitized
14X Rear-Rear Unit Input (RUI) — 2.28 Ratio	A1-1205Z2730	2730T1A	Not Required — Sleeve is unitized
16X/18X Rear-Rear Unit Input (RUI)	A1-1205A2731	2731T1	Not Required — Sleeve is unitized
MTC 4208/4210/4213 Input Shaft Only (Transfer Case)	A1-1205X2728	2728T1	2728T2

Forward input and output seals must be serviced with the seal and sleeve. The service part number provides both when required.

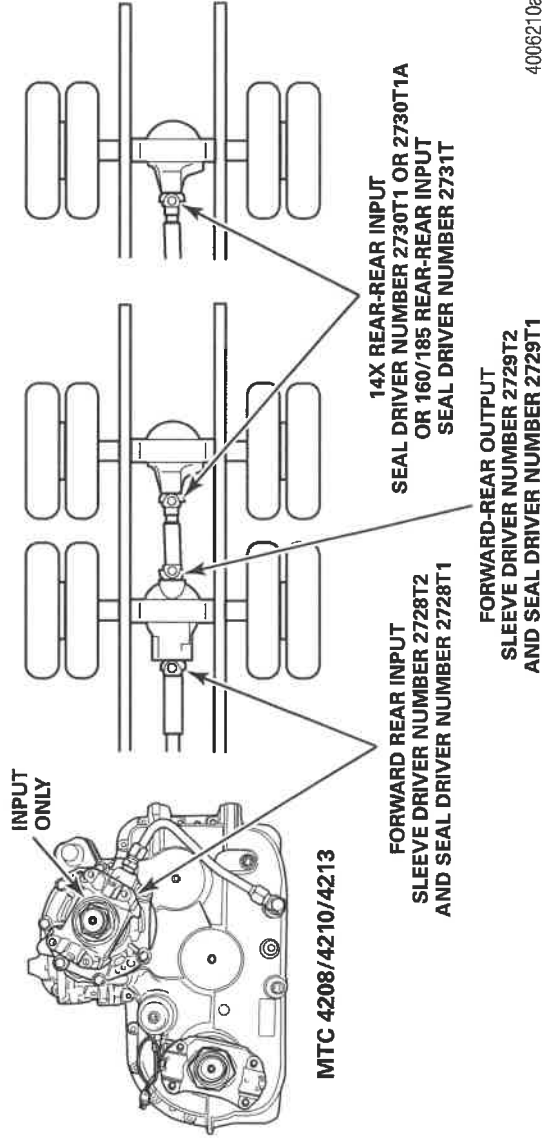

4006210a

Revised 10-15
TP-0464

