

# MERITOR® OFF-HIGHWAY AXLE



**AFTERMARKET OFF-HIGHWAY  
MORH2P032DS4005-1227**



**MERITOR**

PB-12109

# AXLE EXPLODED VIEW

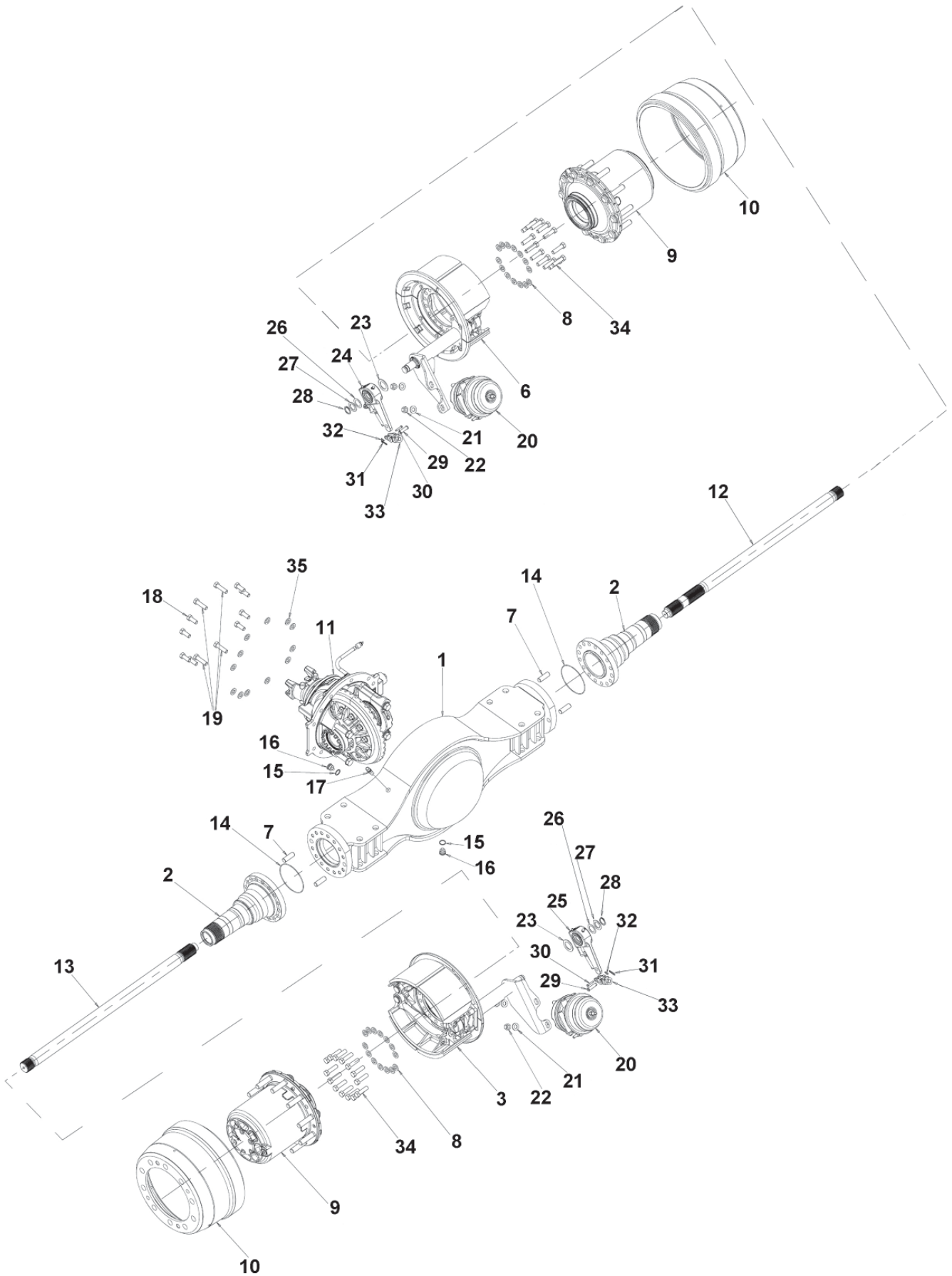

# AXLE COMPONENTS

ITEM	PART NUMBER	DESCRIPTION	QTY (PER AXLE)	REMARKS
1	3201-G-9549	Housing	1	
2	3213-X-2182	Spindle	2	
3 & 6	BG-1657-4722	Brake Assembly w/Chamber	1	
3 & 6	BG-1657-4721	Brake Assembly w/Chamber	1	
7	1246-T-1268	Dowel	4	
8	1229-W-1557	Hardened Washer	28	
9	A3-333-Z-4602	Wheel End Assembly	2	See Wheel Hub For Details
10	'03123698	Drum	2	
11	A1-3200-G-2217 355	Carrier Assembly	1	
12	3802-S-2125	Axle Shaft	1	
13	3802-R-2124	Axle Shaft	1	
14	5-X-1371	Spindle O-Ring	2	
15	949329	Plug Gasket	2	
16	981281	Magnetic Fill Plug	2	
17	KIT 2902	Breather	1	
18	MS216050N-2	Carrier to Housing Bolts	8	40mm
19	MS216070N-2	Carrier to Housing Bolts	4	60mm
20	E21-3276-D-30	Brake Chamber	2	
21	1229-N-1626	Flat Washer	4	
22	N310 1	Nut	4	
23	1229-S-2697	Flat Washer	2	
24 & 25	R803203	Slack Adjuster	1	
24 & 25	R803202	Slack Adjuster	1	
26	1229-N-4590	Shim	4	
27	1229-J-3130	Shim	4	
28	1229-D-2942	Snap Ring	2	
29	19-X-1116	Large Clevis Pin	2	
30	19-X-127	Small Clevis Pin	2	
31	2257-D-1174	Large Clip	2	
32	2257-C-1173	Small Clip	2	
33	1245-Z-1066	Clevis	2	
34	MS216060A-2	Brake Spider to Housing Bolts	28	
35	MWA-516	Flat Washer	12	

# WHEEL END VIEW

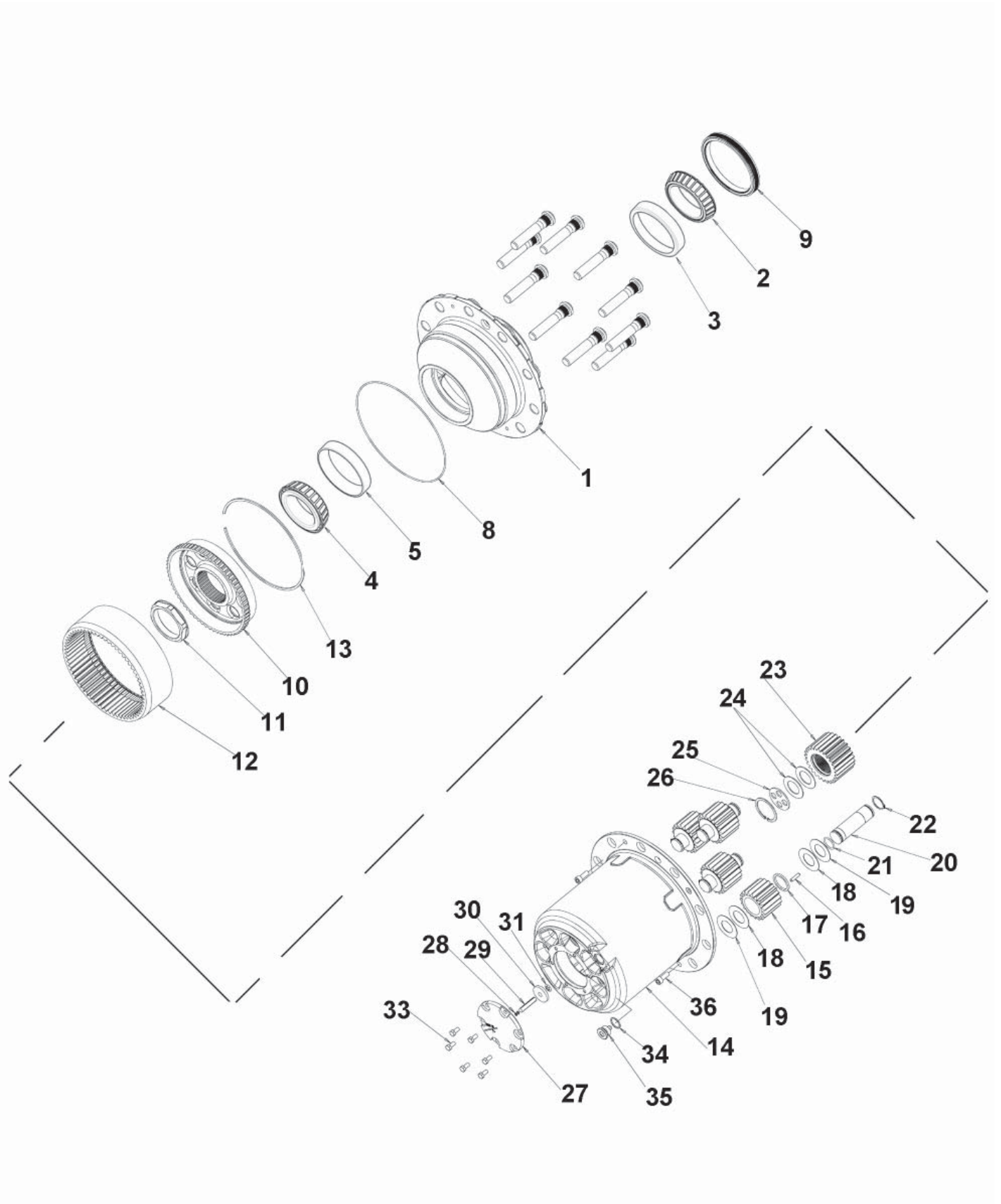

# WHEEL END COMPONENTS

ITEM	PART NUMBER	DESCRIPTION	QTY (PER AXLE)		REMARKS
1	A1-333-Z-4602	Hub and Stud Assembly	2		
2	HM-220149	Inner Bearing Cone	2		99.975mm ID
3	HM-220110	Inner Bearing Cup	2		156.975mm OD
4	6580	Outer Bearing Cone	2		
5	6535	Outer Bearing Cup	2		
8	982108	O-Ring	2		248mm ID x 3mm
9	A-1205-P-2798	Oil Seal	2		
10	3191997	Ring Gear Carrier	2		
11	1227-S-1735	Nut	2		M80 x 2
12	1522380	Ring Gear	2		
13	1522392	Snap Ring	2		
14	A-3298-H-1230	Loaded Planetary Housing	2		
15-22	KIT 6352	Pinion - Planetary, Assembly			
15	1522381	Planet Gear	4		
16	1522387	Needle Bearings	152		28mm x 6.5mm
17	1522388	Spacer Sleeve	4		
18	1522389	Washer, Steel	8		
19	1522390	Washer, Brass	8		
20	1522386	Bearing Spindle	4		
21	949721	O-Ring	4		26.2mm ID x 3mm
22	914463	Snap Ring	4		
23	3892-A-5981	Sun Gear	2		
24	1673500	Spring Washer	4		
25	1522393	Thrust Washer	2		
26	914532	Retaining Ring	2		
27	3262-G-1437	Hub Cap Cover	2		
28	955891	Shim	As Required		0.8mm
29	1523115	Pin	As Required		52mm
29	1523116	Pin	As Required		56mm
30	2297-W-8733	Magnet	2		
31	967581	Clip	2		10mm ID
33	10-X-1783	Hub Cover Bolt	12		M8 x 1.25 -16mm
34	949329	Plug Gasket	2		
35	981281	Oil Fill Plug	2		M24 x 1.5
36	959238	Hub Case Bolt	4		M10 x 1.5 - 25mm

# BRAKE VIEW

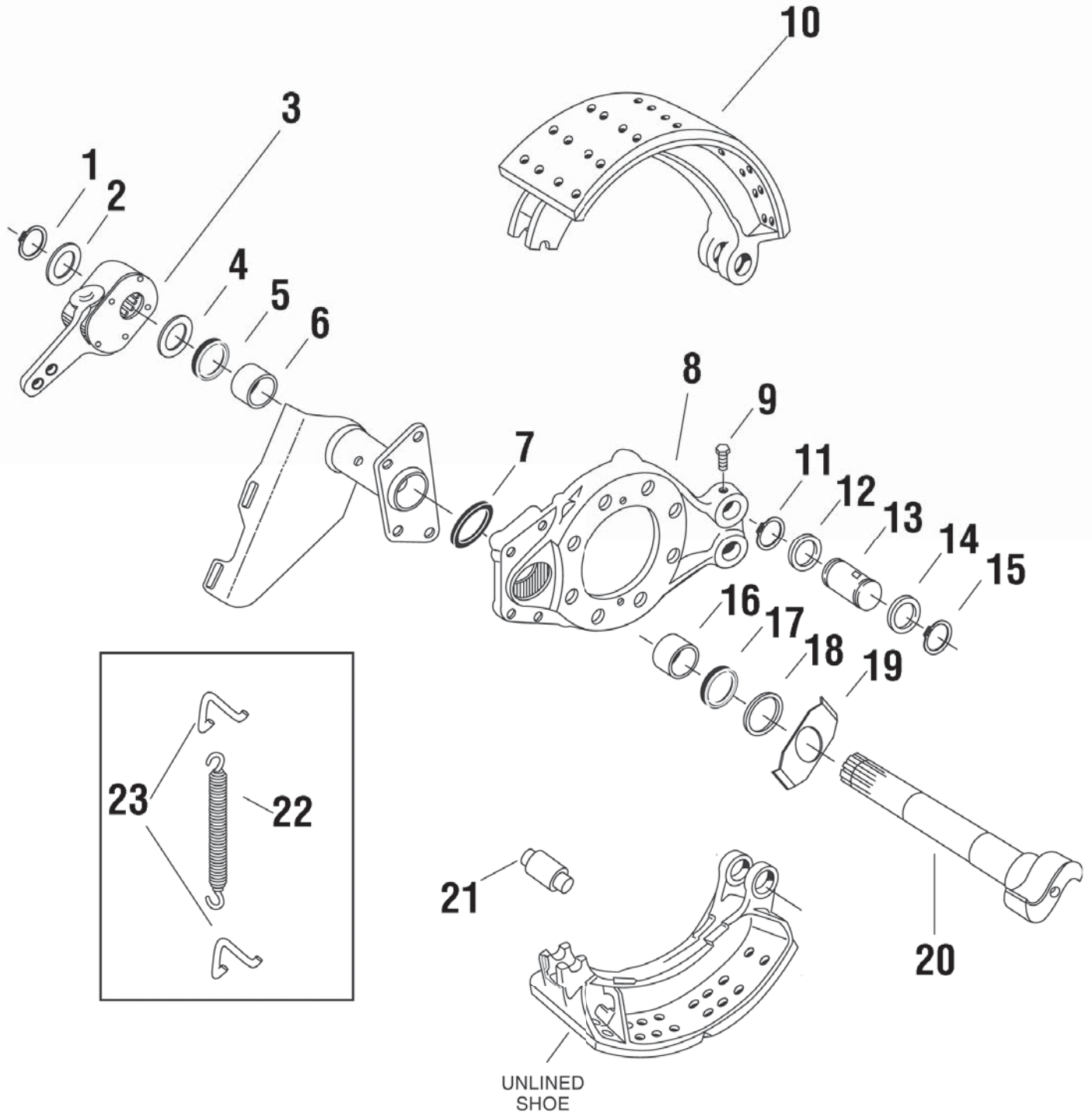

# BRAKE COMPONENTS

ITEM	PART NUMBER	DESCRIPTION	QTY (PER AXLE)	REMARKS
1	1229-D-2942	Snap Ring	5	
2	1229-S-2697	Washer	1	
3	R803203	Slack Adjuster	1	For BG-1657-4722
3	R803202	Slack Adjuster	1	For BG-1657-4721
4	1229-S-2697	Washer	1	
5	A-1205-V-1556	Seal And O-Ring	1	
6	1225-L-1208	Bushings	1	
7	1205-G-761	O-Ring	1	
8	A-3211-P-3604	Spider Assembly	1	
9	S-264B	Capscrew	6	
10	KSR4034515PC	Shoe & Lining Kit	2	
11	1229-X-1116	Snap Ring	1	
12	A-1205-S-1943	Seal And O-Ring	1	
13	1259-N-1132	Pin Anchor	2	
14	A-1205-S-1943	Seal And O-Ring	1	
15	1229-X-1116	Snap Ring	1	
16	1225-L-1208	Bushings	1	
17	A-1205-V-1556	Seal And O-Ring	1	
18	1229-S-2697	Washer	1	
19	1229-N-4590	Flat Washer	2	
20	2210-R-8806	Camshaft	1	For BG-1657-4722
20	2210-S-8807	Camshaft	1	For BG-1657-4721
21	1199-U-3765	Roller Shoe Brake	2	
22	2258-R-590	Spring Return	1	
23	1218-C-107	Spring & Hook	1	
	N94-3299-U-1555	Brake Chamber	1	For BG-1657-4722
	N94-3299-T-1554	Brake Chamber	1	For BG-1657-4721

# CARRIER ASSEMBLY

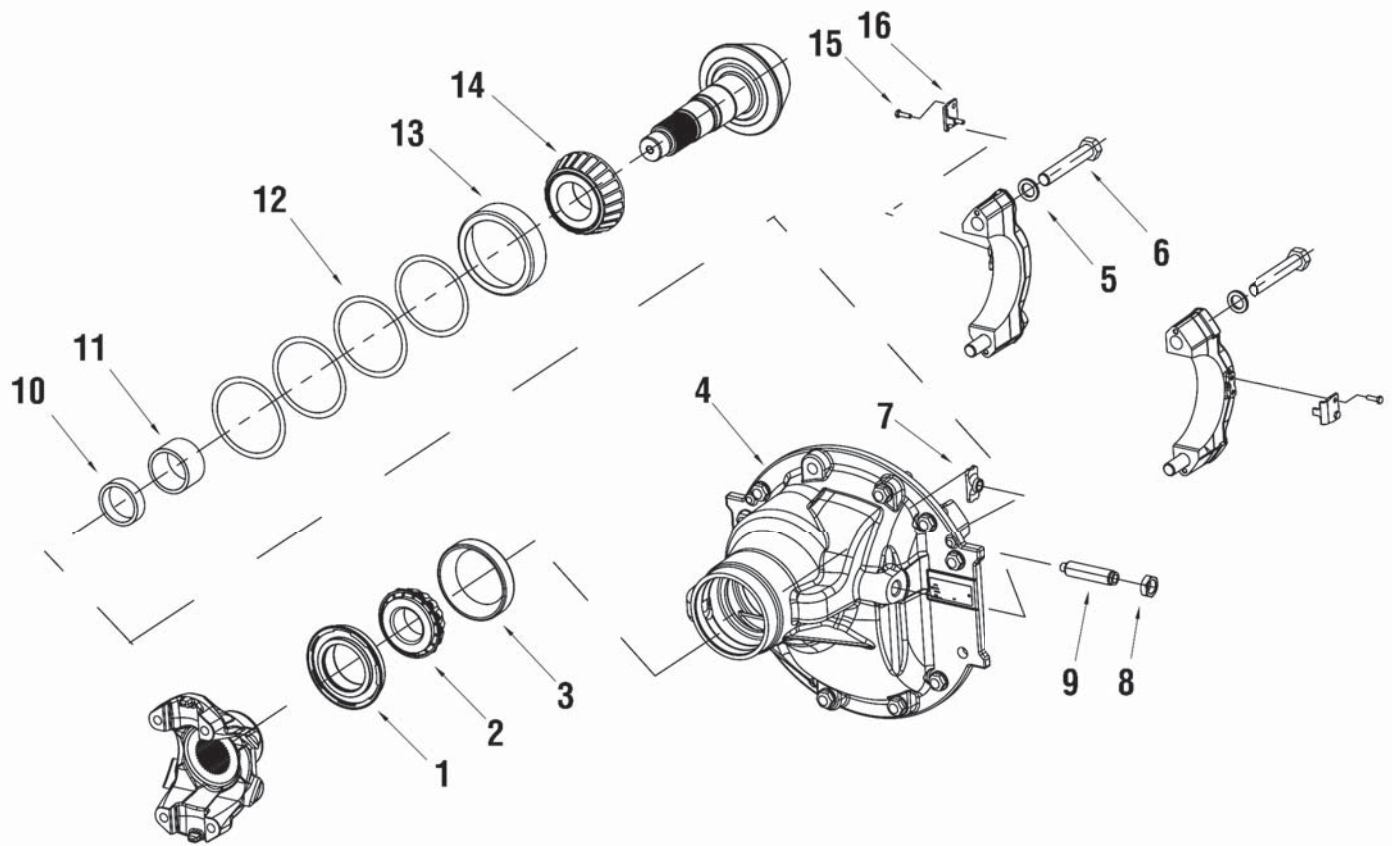



# CARRIER COMPONENTS

ITEM	PART NUMBER	DESCRIPTION	QTY (PER AXLE)	REMARKS
1	A1-1205-Z-2730	Oil Seal	1	
2	A1-1228G605	Bearing Cone - Outer Pinion	1	
3	1228-F-604	Bearing Cup - Outer Pinion	1	
4	A2-3200G2217	Carrier and Cap	1	
5	42X-1021	Washer	4	
6	MS220120-1	Bolt	4	
7	2297-P-8336	Thurst Block	1	
8	40X-1016	Jam Nut	1	
9	10X-1710	Thrust Screw	1	
10	KIT 2541	Kit - Pinion Bearing Spacers	1	
	1244-M2-431	Spacer - Pinion Bearing	2	9.40mm/.370 inch
	1244-N-2432	Spacer - Pinion Bearing	2	9.43mm/.371 inch
	1244-P-2434	Spacer - Pinion Bearing	2	9.45mm/.372 inch
	1244-Q-2435	Spacer - Pinion Bearing	2	9.48mm/.373 inch
	1244-R-2436	Spacer - Pinion Bearing	2	9.50mm/.374 inch
	1244-S-2437	Spacer - Pinion Bearing	2	9.60mm/.378 inch
	1244-T-2438	Spacer - Pinion Bearing	2	9.70mm/.382 inch
	1244-U-2439	Spacer - Pinion Bearing	2	9.80mm/.386 inch
	1244-V-2440	Spacer - Pinion Bearing	2	9.90mm/.390 inch
	1244-W-2441	Spacer - Pinion Bearing	2	10.00mm/.394 inch
	1244-X-2442	Spacer - Pinion Bearing	2	10.10mm/.398 inch
	1244-Y-2443	Spacer - Pinion Bearing	2	10.20mm/.402 inch
	1244-Z-2444	Spacer - Pinion Bearing	2	10.23mm/.403 inch
	1244-A-2445	Spacer - Pinion Bearing	2	10.25mm/.404 inch
	1244-B-2446	Spacer - Pinion Bearing	2	10.28mm/.405 inch
	1244-C-2447	Spacer - Pinion Bearing	2	10.30mm/.406 inch
11	1244-F-2346	Spacer - Inner Pinion Bearing	1	
12	KIT 1647	Kit - Shims - Pinion Bearing	1	
	2203-F-2788	Shim	3	.076mm/.003 inch
	2203-G-2789	Shim	2	.127mm/.005 inch
	2203-H-2790	Shim	4	.254mm/.010 inch
13	1228-Z-1716	Bearing Cup - Inner Pinion	1	
14	A-1228A1717	Bearing Cone - Inner Pinion	2	
15	41X-1669	Screw - Diff Adjusting Ring Lock	2	
16	1220-P-1108	Lock - Diff Adjusting Ring	4	

# CARRIER ASSEMBLY

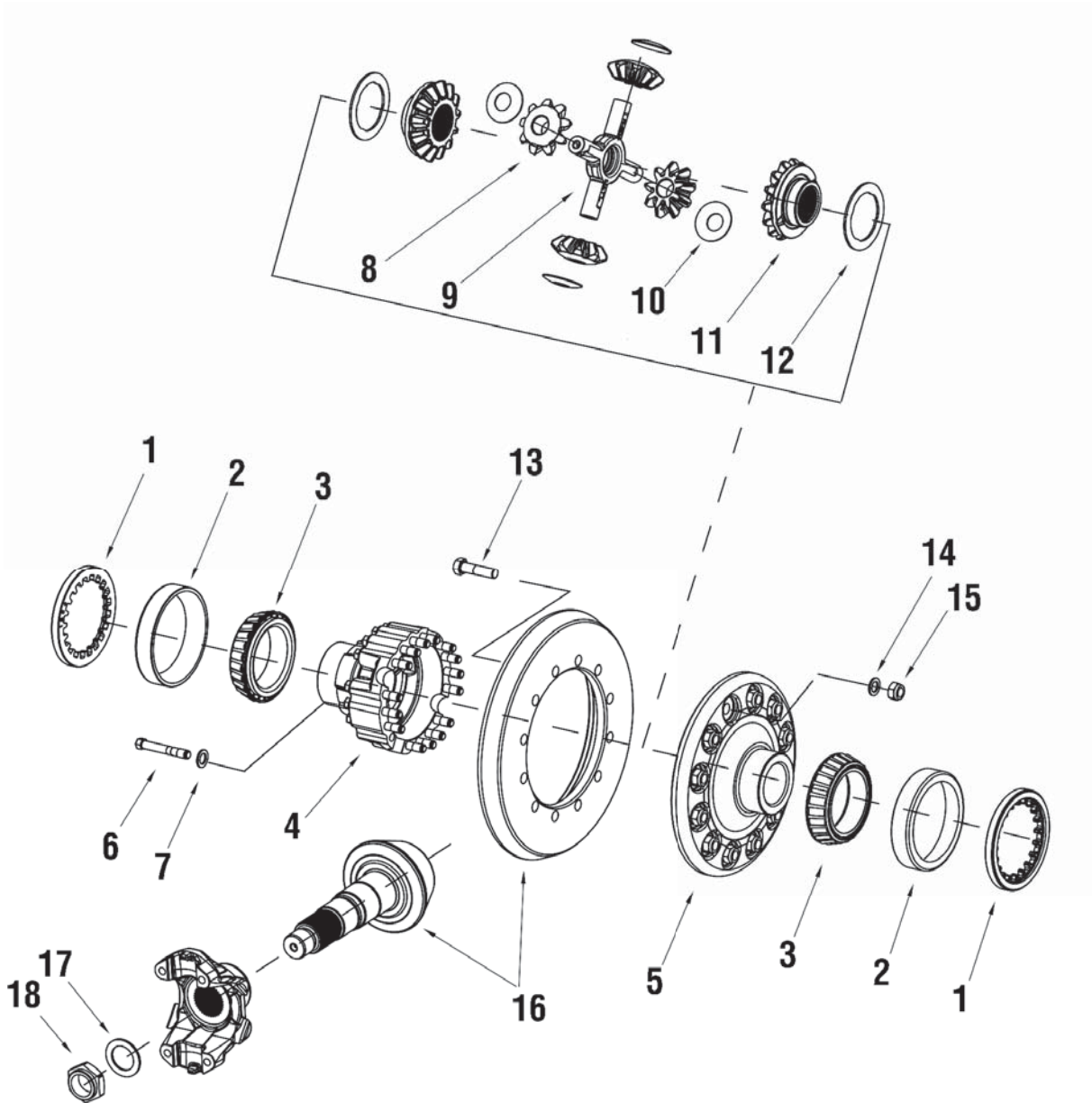

# CARRIER DIFF COMPONENTS

ITEM	PART NUMBER	DESCRIPTION	QTY (PER AXLE)	REMARKS
<b>Diff Components</b>				
1	2214-G-1255	Adjusting Ring - Main Diff	2	
2	1228-Q-1473	Bearing Cup - Main Diff	2	
3	A-1228-R-1474	Bearing Cone - Main Diff	2	
<b>Diff Case Assemblies</b>				
4-12	A1-3235-E-2787	Main Diff Assembly	1	3.42-411
4-7	A-3235-E-2787	Diff Case Assembly	1	3.42-411
4	3235-J-2792	Diff Case - Plain Half	1	All
5	3235-E-2787	Diff Case - Flange Half	1	3.42-411
6-7	KIT 2819	Kit - Diff Case Bolts	1	All
6	41X-1327	Bolt - Diff Case	16	
7	1229-D-4632	Washer - Diff Case	16	
<b>Main Diff Components</b>				
8-12	KIT 4778	Kit - Main Diff	1	
8	1229-Q-5087	Thrust Washer - Main Diff Side Gear	2	
9	2234-G-1437	Side Gear - Main Diff	2	
10	1229-R-1032	Thrust Washer - Main Diff Pinion	4	
11	3278-S-305	Spider - Main Diff	1	
12	2234-J-1024	Pinion Gears - Main Diff	4	
13-15	KIT 2317	Kit - Bolt Kit - Diff Case to Gear	1	
13	41X-1216	Bolt	12	
14	1229-U-1503	Washer	12	
15	40X-1182	Nut	12	
16	A-42204-1R-355	Gear Set	1	
	KIT 2637	Kit - Pinion Nut and Washer	1	
17	1229-T-1736	Pinion Washer	1	
18	40X-1237	Pinion Nut	1	



**MERITOR®**

**Meritor Heavy Vehicle Systems, LLC**  
7975 Dixie Highway  
Florence, KY 41042 USA

**For more information:**

**U.S. 888-725-9355**

**Canada 800-387-3889**

**[XpresswayPlus.com](http://XpresswayPlus.com)**

**[meritor.com](http://meritor.com)**

Vehicle models, brands and names depicted herein are the property of their respective owners, and are not in any way associated with Meritor, Inc., or its affiliates.

Litho in USA Issued 06-12  
PB-12109 (FLOA)  
©2012 Meritor, Inc.