



Hydraulic Anti-Lock Brake System Modulator Assembly Bracket Replacement Procedure

Kit R955452

Hazard Alert Messages

Read and observe all Warning and Caution hazard alert messages in this publication. They provide information that can help prevent serious personal injury, damage to components, or both.

How to Obtain Additional Maintenance and Service Information

Refer to Maintenance Manual MM-0677, Hydraulic Anti-Lock Braking Systems (HABS) for Medium-Duty Trucks, Buses and Motor Home Chassis For E-Version Hydraulic ABS. To obtain this publication, visit our website at www.meritorwabco.com.

How to Obtain Kits

Call ArvinMeritor's Commercial Vehicle Aftermarket at 888-725-9355.

Kit: R955452

Part Description	Part Number	Quantity
Bracket	478 901 352 2	1
Bolt	891 490 000 4	3
HABS Bracket Replacement Procedure	TP-0772	1

Before You Begin

CAUTION

The modulator assembly contains hydraulic brake fluid. Hydraulic brake fluid is a caustic substance. Contact with hydraulic brake fluid can cause skin irritation. Do not let hydraulic brake fluid touch any painted surfaces as it will remove the paint. Hydraulic brake fluid may also damage certain non-metal surfaces. Do not let fluid get on brake pads, shoes, rotors or discs. Follow the safety precautions described in Maintenance Manual MM-0677.

WARNING

When any hydraulic system fitting is loosened or disconnected, the entire system must be bled to remove any air that may have entered. Failure to bleed the system whenever any hydraulic system fitting is loosened or disconnected will allow air to remain in the system. This will prevent the hydraulic pressure in the brake system from raising enough to apply the brakes correctly. This will cause the stopping distance to increase and can result in serious personal injury. Follow the brake bleeding procedures described in Maintenance Manual MM-0677.

Follow the procedure in Maintenance Manual MM-0677 for removal of the old modulator assembly bracket.

Installation

WARNING

To prevent serious eye injury, always wear safe eye protection when you perform vehicle maintenance or service.

Park the vehicle on a level surface. Block the wheels to prevent the vehicle from moving. Support the vehicle with safety stands. Do not work under a vehicle supported only by jacks. Jacks can slip and fall over. Serious personal injury and damage to components can result.

1. Wear safe eye protection.
2. Park the vehicle on a level surface. Block the wheels to prevent the vehicle from moving.
3. Position the modulator assembly and bracket in place on the vehicle. Figure 1.

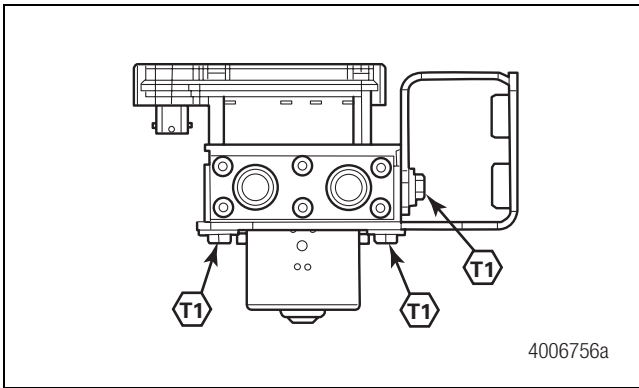



Figure 1

4. Install three mounting bolts and nuts. Tighten to 16.0 ± 4.0 ft-lb (22.0 ± 5 N•m). 
5. Ensure the brake line connections are tight.
6. Bleed the brake system, if necessary, following the procedures in Maintenance Manual MM-0677.

MERITOR WABCO

Meritor WABCO Vehicle Control Systems
2135 West Maple Road
Troy, MI 48084-7121 USA
800-535-5560
meritorwabco.com

Information contained in this publication was in effect at the time the publication was approved for printing and is subject to change without notice or liability. Meritor WABCO reserves the right to revise the information presented or to discontinue the production of parts described at any time.

Copyright 2007
ArvinMeritor, Inc.
All Rights Reserved

Printed in USA

TP-0772
Issued 09-07
(16579/22882)