

MERITOR WABCO

Technical Bulletin

R955423 or R955425 Meritor WABCO Enhanced Easy-Stop™ Trailer ABS 2S/1M Replacement Kits for Wabash National MBS-2 Equipped Trailers

Hazard Alert Messages

Read and observe all Warning and Caution hazard alert messages in this publication. They provide information that can help prevent serious personal injury, damage to components, or both.

Overview

Effective March 2004, Wabash National made Meritor WABCO trailer ABS the standard product for use with their trailers. Wabash National's MBS-1, MBS-1P, and MBS-2 products are no longer available. Meritor WABCO's Enhanced Easy-Stop™ trailer ABS product can be used to replace Wabash National's MBS-1, MBS-1P, and MBS-2 products.

This bulletin covers the replacement of MBS-2 products with Meritor WABCO Enhanced Easy-Stop™ 2S/1M. For MBS-1 or MBS-1P product replacement, please contact the ArvinMeritor Customer Service Center at 800-535-5560.

To complete the MBS-2 ABS replacement for the trailer you will need the following:

- One trailer ABS replacement kit
- Two replacement hubs with tone rings **only** if hubs are not already machined
- One sensor mounting block fixture will be needed at the point of installation. This tool may be reused from trailer to trailer. (Refer to the Special Tools section at the back of this publication.)
- Meritor WABCO recommends an in-line filter (432 500 005 0) be installed at the gladhands to protect the trailer ABS components.
- A Meritor WABCO trailer ABS wall chart (TP-0692) is available to further identify Meritor WABCO components correctly for future service needs. This wall chart is available from our literature fulfillment center (800-535-5560).

Trailer ABS Replacement Kit

Replacement Kit for 2S/1M Slider or 4S/1M MBS-2 Equipped Trailers — R955423

NOTE: R955425 includes the same bill of material, but excludes tone rings for retrofits where new hub assemblies will be used.

- 12-volt integrated electronic control unit (ECU)/modulator valve assembly, 400 500 101 0
- 4.7-meter power cable, 449 326 047 0
- 1.0-meter sensors (2), 441 032 808 0
- Sensor clips (2), 899 759 815 4
- Lubricant packets for sensors (2), 884 490 307 4
- 1.8-meter sensor extension cables (2), 449 713 018 0
- 1/2 - 14 NPTF filler plug (top of axle) with pre-applied sealant (2), P-48S
- Spindle end plugs for WP style axle spindles (4), 1250F526
- Sealant for spindle end plugs (4), 2297B7048
- Sensor mounting blocks (2), 2255-T-1346
- Tone rings (2), 09001867
- Installation Guide, TP-06110
- Meritor WABCO Trailer ABS Quick Reference Guide, TP-0173
- Wabash National offered the MBS-2 platform in 2S/1M, 4S/1M and 2S/2M configurations. The R955423 and R955425 replacement kits are designed to retrofit a MBS-2, 2S/1M or 4S/1M equipped trailer to an Enhanced Easy-Stop™ 2S/1M equipped trailer. For 2S/2M configurations, order replacement kit R955426 or R955427.
- Trailer ABS sticker, TP-95172

Replacement Hubs (Hub, Cup, Studs, Tone Ring)

Replacement hubs with tone rings will be needed if the existing hubs are not machined to allow for insertion of tone rings. Tone rings are provided in the replacement kit and do not need to be ordered separately. Please consult ArvinMeritor Parts Book PB-2006 for additional information on replacement hubs.

- Meritor WABCO offers two versions of this kit; R955423 for retrofits that the existing hubs will use after tone rings are installed, and R955425 for retrofits that will use new hub assemblies. The existing hubcaps can be reused with either the existing hubs or the new hub assemblies.

Table A: WP Axles — Stud Piloted

Wheel Type	Drum Type	Hand	Hub Number
Steel/Aluminum	Cast	Right-Hand	04-15968-014
Steel/Aluminum	Cast	Left-Hand	04-15968-015

Table B: WP Axles — Hub Piloted

Wheel Type	Drum Type	Hand	Hub Number
Steel/Aluminum	Cast	Left/Right	04-15968-007
Aluminum	Cast/X30	Left/Right	04-15968-009

Removal and Installation

Remove the Wabash National MBS-2 Electronic Control Module (ECM) and Pneumatic Control Module (PCM)

WARNING

To prevent serious eye injury, always wear safe eye protection when you perform vehicle maintenance or service.

The Anti-lock Braking System (ABS) is an electrical system. When you work on the ABS, take the same precautions that you must take with any electrical system to avoid serious personal injury. As with any electrical system, the danger of electrical shock or sparks exists that can ignite flammable substances. You must always disconnect the battery ground cable before working on the electrical system.

Release all pressure from the air system before you disconnect any components. Pressurized air can cause serious personal injury.

Park the vehicle on a level surface. Block the wheels to prevent the vehicle from moving. Support the vehicle with safety stands. Do not work under a vehicle supported only by jacks. Jacks can slip and fall over. Serious personal injury and damage to components can result.

CAUTION

Use the following procedures to avoid damage to the electrical system and ABS components.

When welding on an ABS-equipped vehicle is necessary, disconnect the power connector from the ECU.

1. Wear safe eye protection.
2. Park the vehicle on a level surface. Block the wheels to prevent the vehicle from moving.
3. Discharge all of the pressure from the air system.
4. Attach labels to identify all air lines.
5. Disconnect and remove the air lines from the ECM/PCM.
6. Disconnect the power/diagnostic cable from the ECM/PCM.
7. Disconnect the axle feed-through cable (cable for in-axle sensors) from the ECM/PCM.

8. Disconnect the accessory cable from the ECM/PCM.
9. Remove the ECM/PCM from its mounting location (either on the air tank or on the frame of the vehicle).

Remove the Wabash National MBS-2 Axle Feed-Through Cables

1. Pull the axle feed-through cable from the axle and cut the cable near the Y-intersection of this cable. Refer to Figure 3.
2. Remove the axle feed-through cable.
3. Disconnect the sensors from the axle feed-through cable, pushing the sensor cables back into the axle.

Prepare the Axle for Removal of the In-Axle Sensors and Installation of Spindle End Plugs

CAUTION

Use a clean towel to cover the wheel ends at both ends of the axle during system installation to prevent contaminants from entering the wheel end. Contaminants may damage the bearings and seals.

1. Place a container under the hubcap to receive the draining oil. Then, remove the hubcap and hubcap gasket from both ends of the axle. Figure 1. Do not reuse either the hubcap gasket or the oil.

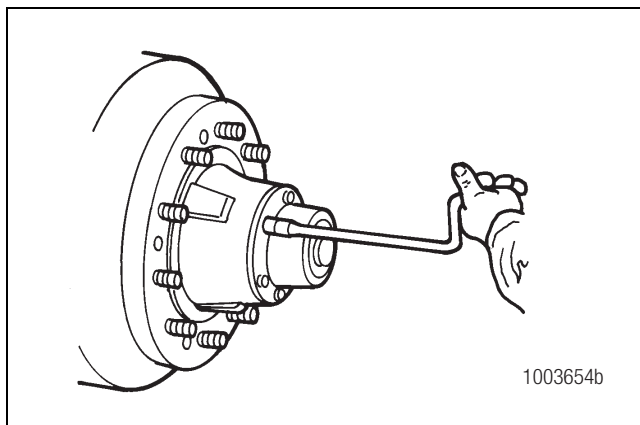

Figure 1

2. Cover the wheel ends at both ends of the axle with a clean towel. Figure 2.

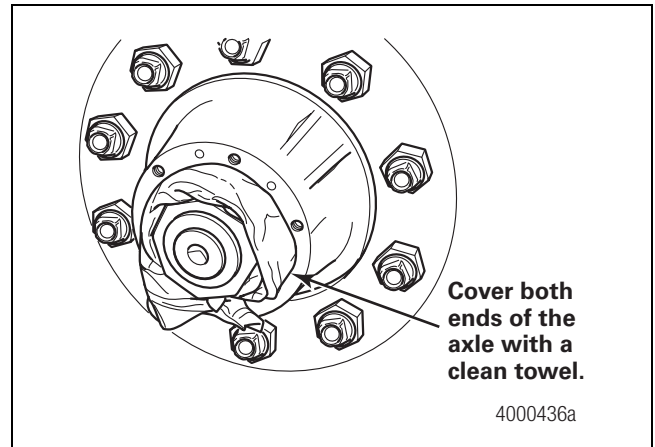

Figure 2

NOTE: If the trailer is also equipped with the Meritor Tire Inflation System (MTIS) by P.S.I.[™], you will need to remove the existing stator and press plug from the axle spindle. Each MTIS press plug will need to be replaced with a TP-style press plug, part number 32184-01A, while the stator can be reused. Refer to Step 5 for the correct procedure to remove the press plug.

3. Remove the 1/2-inch bolt and wave washer from the in-axle sensor. Then remove the in-axle sensor from the axle spindle, unplugging the grey (roadside) or black (curbside) connector from the back of the sensor. Figure 3.

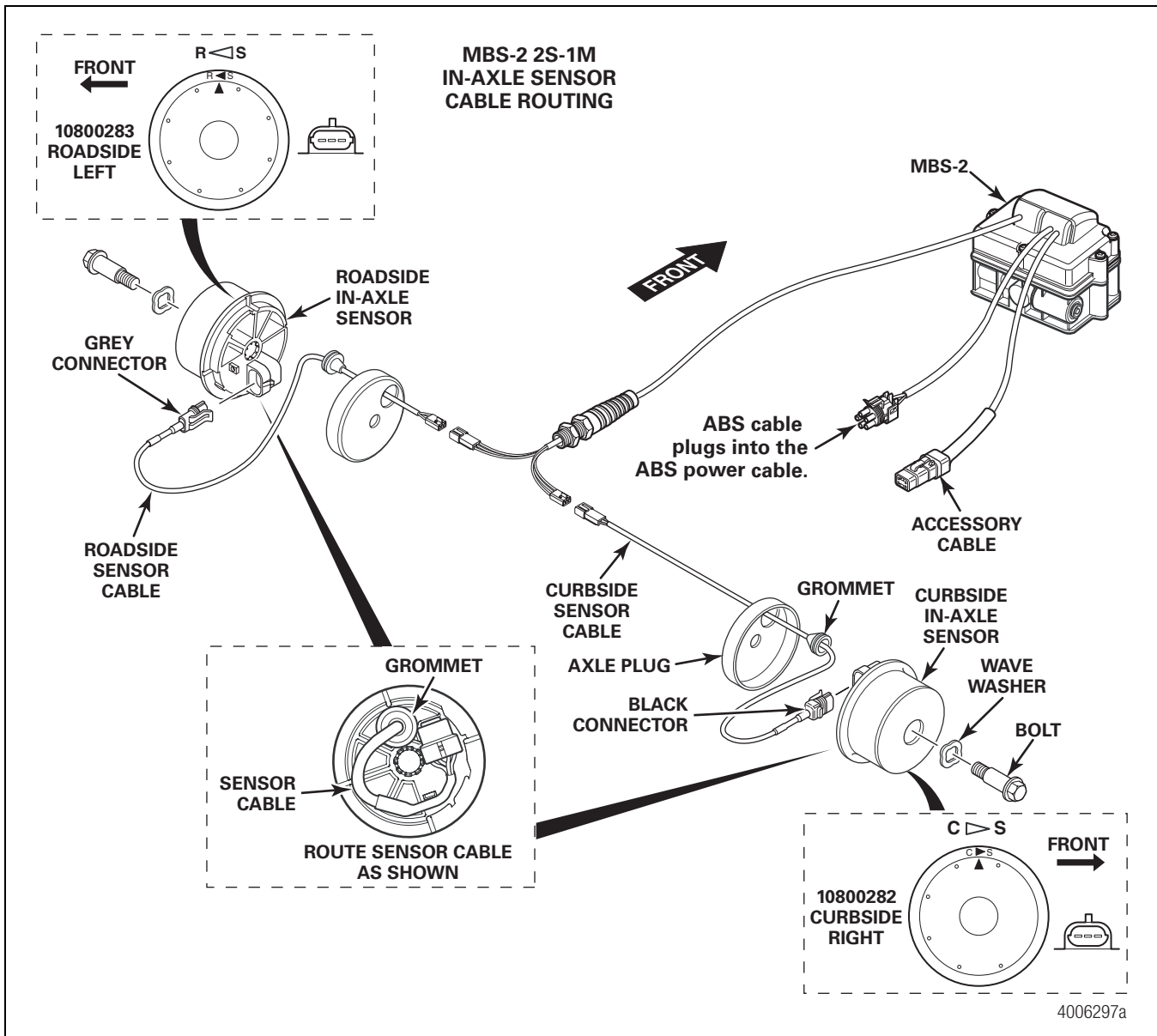

Figure 3

4. Remove the sensor cable and grommet from the axle spindle.
5. Use a slide hammer fitted with the spindle end plug removal spear to remove the spindle end plugs from both ends of the axle. Use care not to score the inside diameter of the spindle bore. Figure 4. A slide hammer with spindle end plug removal spear to help remove these plugs is available from ArvinMeritor. Refer to the Special Tools section at the back of this document for part numbers of special tools and supplies.

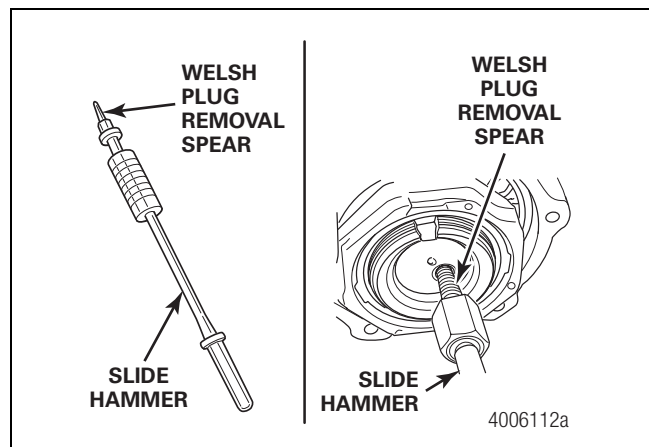

Figure 4

⚠ CAUTION

Use a bore polisher to remove all old adhesive from the spindle bore before you apply retaining compound to install the press plug. Retaining compound must contact a bare metal surface or it will not harden. Damage to components can result.

6. Choose the correct size bore polisher by matching the axle manufacturer and model to the bore polishing tools listed in the back of this publication. Figure 5.

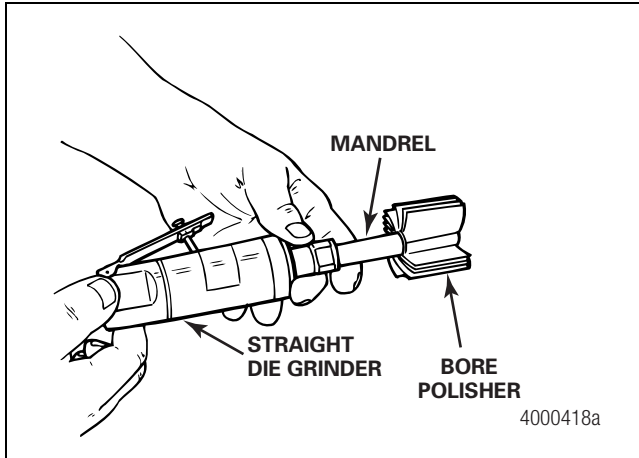

Figure 5

7. Polish the spindle bore to remove all adhesive residue left from the old spindle plug and any metal burrs or sharp edges from the spindle bore surface. Figure 6.
 - If the axle spindle is equipped with cotter pin holes: Use a round abrasive tool to remove all metal burrs and sharp edges from the spindle bore side of the cotter pin holes. Figure 7.

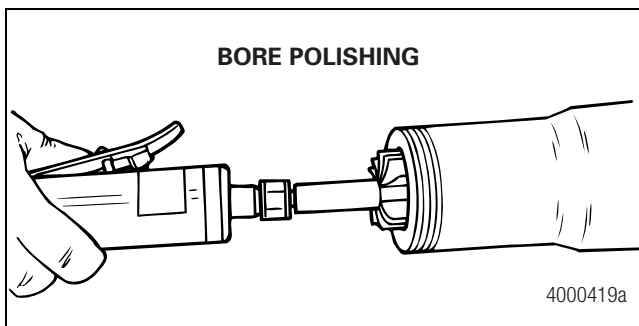

Figure 6

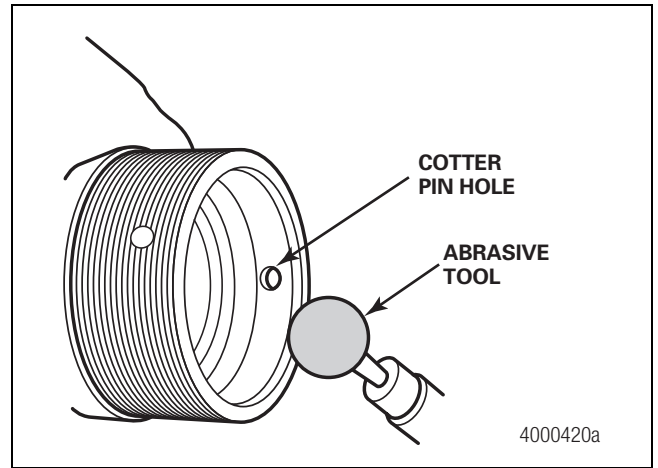

Figure 7

⚠ CAUTION

Use a cleaning wand and high-volume air to clean debris from the axle interior before you install the spindle end plugs. Check that the axle is clear of debris, including loose rust, scale, liquid, and machining residue.

8. Connect a cleaning wand to a high-volume air supply. Refer to Figure 8 for information on building a cleaning wand. Figure 8. Slowly push the wand through the axle until it exits the opposite end. During this operation, a steady stream of air will flow from the opposing axle spindle. Figure 9.

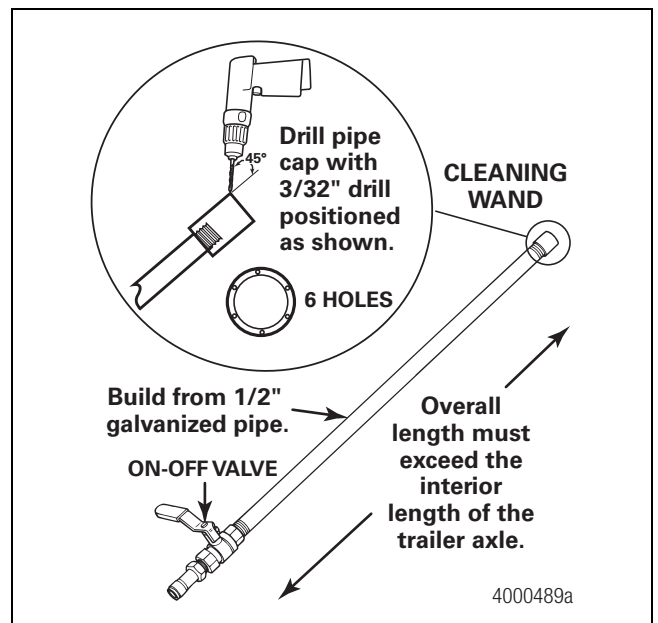

Figure 8

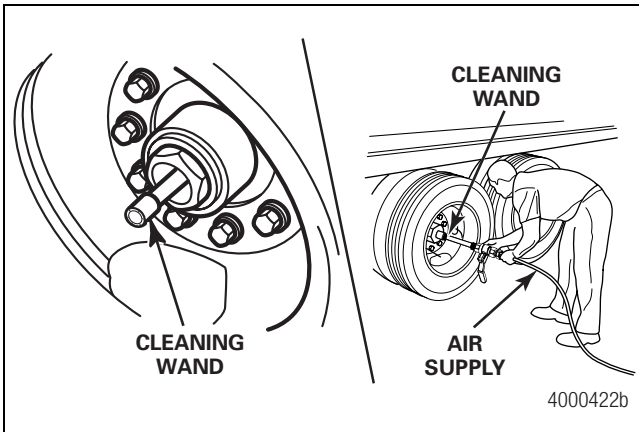

Figure 9

9. Check the inside of the axle tube with a flashlight by shining the light into one end of the spindle and looking through the opposite end. Confirm that all debris, including loose rust, scale, liquid and machining residue has been removed. Figure 10.

- **If necessary:** Repeat the cleaning procedure until the axle is clear of debris. For debris that's difficult to remove, it may be helpful to push the cleaning wand through the axle from the opposite end.

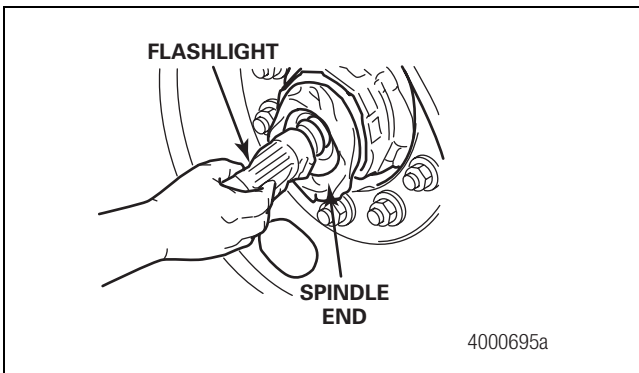

Figure 10

10. Choose the correct press plug drive adaptor by matching the axle manufacturer and model to the press plug drive adaptors. Refer to the special tools section at the back of this document for part numbers of special tools and supplies. Figure 11.

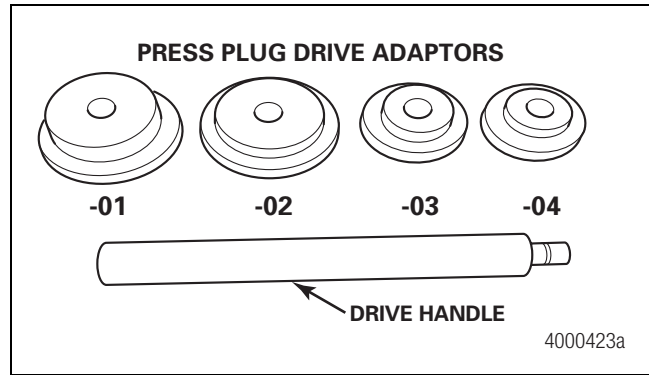

Figure 11

11. Install the press plug drive adaptor onto the drive handle. Figure 12.

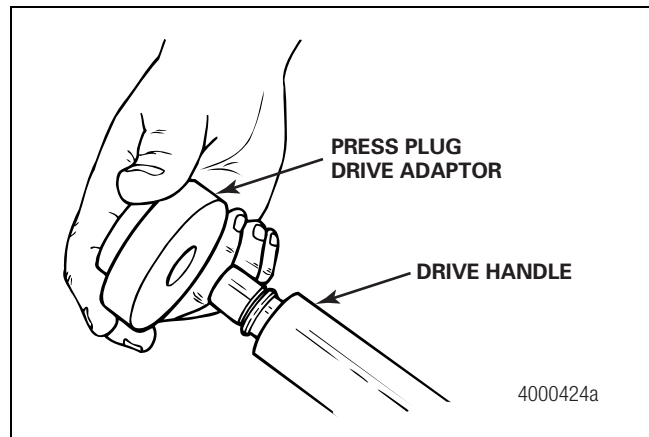

Figure 12

12. Use a moist towelette to clean one spindle bore of contaminants such as grinding dust, dirt, and wheel-end lubricant. Protect the cleaned bore from additional contaminants. Figure 13.

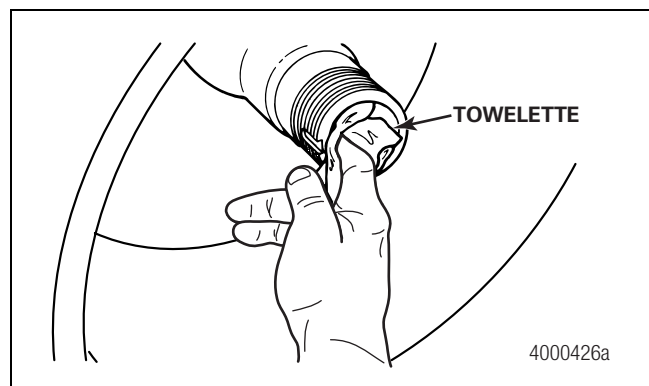

Figure 13

⚠ CAUTION

Use the retaining compound supplied in the installation kit only when you install the press plug. Apply retaining compound to the **OUTSIDE** diameter of the press plug only. Do not apply it to the inside diameter of the spindle bore, press plug stator threads or axle spindle threads. Damage to components can result.

- Put on a new pair of latex gloves. Apply the retaining compound included in the installation kit evenly to the **OUTSIDE** diameter of the press plug. The installation kit contains enough retaining compound for four wheel ends. The press plug must be installed within 10 minutes of applying the hardening compound to ensure that the compound hardens correctly. Figure 14.

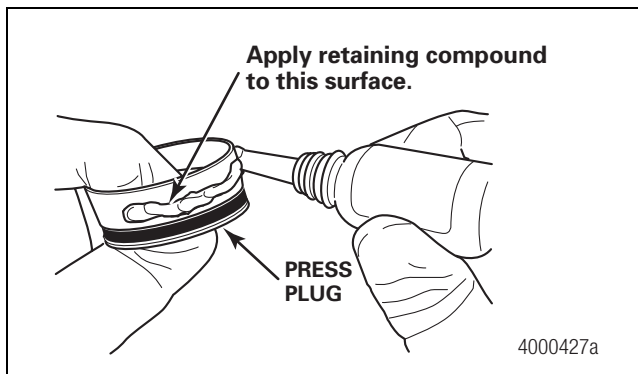

Figure 14

- Insert the press plug into the spindle bore until the plug stops in the bore. Figure 15.

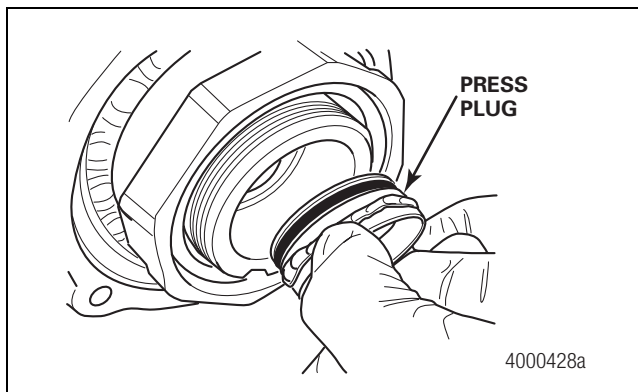

Figure 15

- Check that the press plug protrudes from 1/8-1/4-inch (3.175-6.35 mm) from the end of the spindle. Figure 16.
 - If the press plug protrudes outside this acceptable range: Before proceeding, contact ArvinMeritor's Customer Service Center at 800-535-5560.

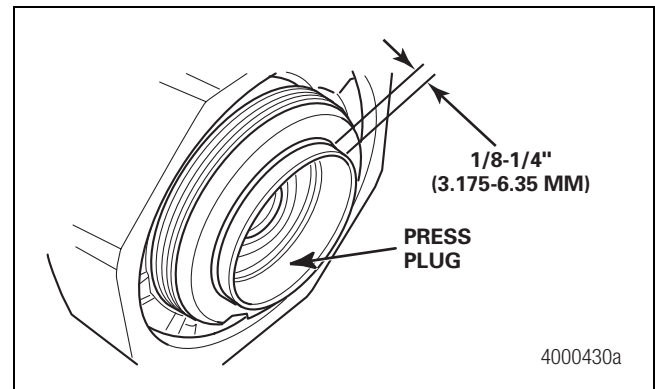

Figure 16

NOTE: If the trailer is equipped with a 2S/1M set-up, continue to install the Sensor Mounting Blocks in this section. If the trailer is equipped with a 4S/1M set-up, repeat Steps 1-16 for the other trailer axle to remove the existing MBS-2 sensors.

- Insert the press plug drive adaptor into the press plug. Figure 17.

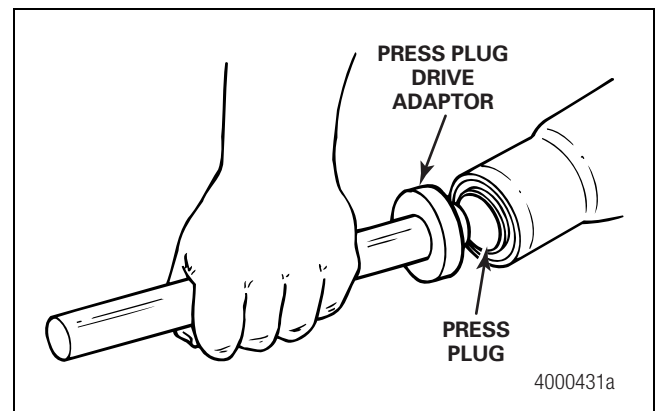

Figure 17

Install the Sensor Mounting Blocks

⚠ CAUTION

You must follow your company's safety procedures when installing sensor mounting blocks. An arc-type welding device will be used during installation so make sure all fire safety regulations are followed. Serious personal injury can occur if safety procedures are not followed.

NOTE: Sensors may be installed on either axle, depending upon suspension and other vehicle characteristics.

- Ensure your axles are correctly supported by jack stands.
- Access axle spindles by removing tires, drums, rotors, (this only applies to disc brake applications), hub and bearing assembly, and brake assembly.

3. Clean spindle from oil or grease.
4. Install locating fixture onto the axle spindle inboard bearing surface.
5. Secure rubber strap around bearing surface and attach it to the eyelet on the other side of the fixture.
6. Slide the fixture inward until it stops at the rear-bearing stop.
7. Turn the locating fixture to the recommended correct clock positions: 2, 4, 8, 10 o'clock.
8. Install sensor mounting block onto the locator, making sure the fixture has not moved from the desired position.
9. Place an approximate 1/8-inch (3.175 mm) weld along the side of the sensor mounting block to secure.
10. Remove fixture, let cool then continue.
11. After cool down, install sensor spring clip and sensor.

Install a Tone Ring

CAUTION

When installing an ABS system, Meritor WABCO recommends the use of new manufactured ABS hub assemblies. Machining an older hub with insufficient hub wall thickness could result in serious property or personal injury. Extreme care should be taken when using open flame heating devices.

1. Clean the hub area to accept the tone ring.
2. Heat the tone ring to 230-250° F (110-121° C).

NOTE: Meritor WABCO recommends the use of an oven type heating device. An open flame device can be used, with the following precautions.

- Place the ring on a 1/4-inch thick X 12-inch wide X 12-inch long plate.
 - Mount a heating device under the plate.
 - With the ring on the plate, check the tone ring temperature using a weld stick registered at 230° F (110° C).
 - When the weld stick starts melting, the tone ring is ready to be installed onto the machined hub.
3. Using pliers and/or welding gloves, remove the tone ring from the heat source and center it onto the machined surface area of the hub bore.
 4. While the tone ring is still hot, make sure that it is correctly centered on to the machine surface and seated to the bottom surface. The hub assembly should be placed so the ring can be installed in a horizontal position.

5. The tone ring should slide into the hub until it bottoms out. If needed, use a rubber mallet to tap the ring onto the hub until it bottoms out. Let the assembly cool naturally.

CAUTION

Do not use any cold substance to cool off the hub assembly, as this could damage the hub and tone ring and possibly cause personal injury.

6. Once the hub assembly cools, install the hub assembly onto the wheel end to the manufacturer's specifications. Use a dial indicator to check the runout of the tone ring teeth.
7. Rotate the hub assembly. **The runout should not exceed ±0.005-inch (0.127 mm).**
8. Repeat as necessary for other ABS sensed wheel ends.

Install the New ECU/Valve Assembly

Attach the replacement ECU/modulator valve assembly to a cross member of the trailer or to the air tank. If possible, mount the replacement assembly in the same location as the old assembly. However, the 2S/1M replacement assembly may be taken apart and the ECU and valve may be mounted separately. Contact ArvinMeritor's Customer Service Center at 800-535-5560 for more information.

NOTE: Based on the existing lengths and positions of the MBS-2 ECM/PCM and air tank on the trailer, it may be necessary to install new air hose lines including but not limited to the control line. Union-tee fittings should not be used to extend an existing air hose line.

Air Tank-Mounted

⚠ WARNING

Release all pressure from the air system before you disconnect any components. Pressurized air can cause serious personal injury.

You must use a Steel Schedule 80 hex nipple fitting (3/4-inch [19.05 mm] NPTF) to mount the ECU/modulator valve assembly securely to the air tank to avoid possible serious personal injury and damage to the component.

⚠ CAUTION

Meritor WABCO does not recommend use of a vise when installing the hex nipple fitting to the valve. Use of a vise may cause internal damage by overclamping or twisting the part in the vise. If part is recognized as having been in a vise, warranty may be forfeited.

1. Use a 3/4-inch (19.05 mm) Steel Schedule 80 hex nipple fitting to attach the ECU/modulator valve assembly to the reinforced air tank. Do not overtighten.
2. Use a 3/4-inch (19.05 mm) pipe plug in the unused supply port. Apply SAE-standard, DOT-approved Teflon tape or paste-type thread sealant to all pipe threads beyond the first two threads. Pipes with pre-applied thread sealant may also be used.
3. Rotate and tighten the ECU/modulator valve assembly until the exhaust port faces DOWN and the connection is secure. Use a torque wrench or ratchet with the extension at the 3/4-inch (19.05 mm) pipe plug installed on the front supply port. Figure 18.

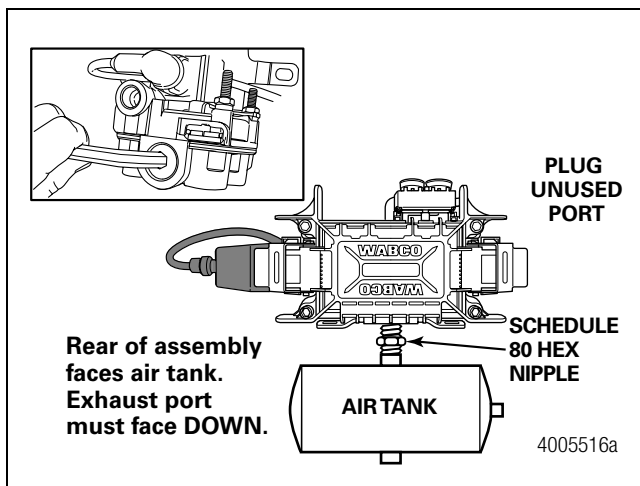

Figure 18

Cross Member-Mounted

NOTE: If attaching the replacement assembly to the vehicle cross member, it will be necessary to drill new mounting holes.

NOTE: For Meritor RHP suspensions, the cross members have pre-drilled mounting holes designed for flexibility in the installation of the Meritor WABCO ECU/valve assembly.

1. Install a 3/4-inch (19.05 mm) NPTF fitting in the supply port.
2. Use a 3/4-inch (19.05 mm) pipe plug in the unused supply port. Apply SAE-standard, DOT-approved Teflon tape or paste-type thread sealant to all pipe threads beyond the first two threads. Pipes with pre-applied thread sealant may also be used.
3. Mark the location of the two mounting holes on the vehicle cross member, then drill two 3/8-inch (9.52 mm) holes into the vehicle cross member. Recommended mounting location is midway between the side rails, close to the brake chambers served by the valve.
4. Attach the replacement assembly to the vehicle. Use two 3/8-inch (9.52 mm) Grade 8 bolts with prevailing torque nuts and washers to attach the assembly to the vehicle cross member. Tighten the bolts to 18 ft-lb (24 N•m). Figure 19. **ⓘ**

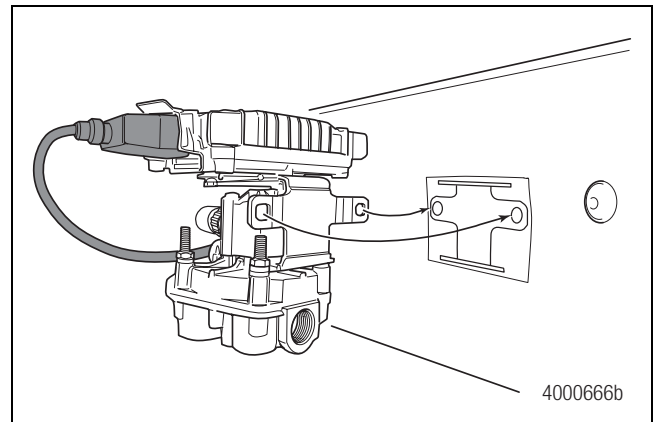

Figure 19

Attach the Air Lines to the Replacement Assembly

1. Remove the markers from the air lines.
2. Attach the air delivery lines from the service chambers to the delivery ports (Port 2) on the ECU/single modulator valve assembly. Delivery ports are located on the bottom of the assembly. Refer to Figure 22 for port locations.
3. Connect the brake service control line (blue line) to Port 4 on the ECU/modulator valve assembly. Figure 20.

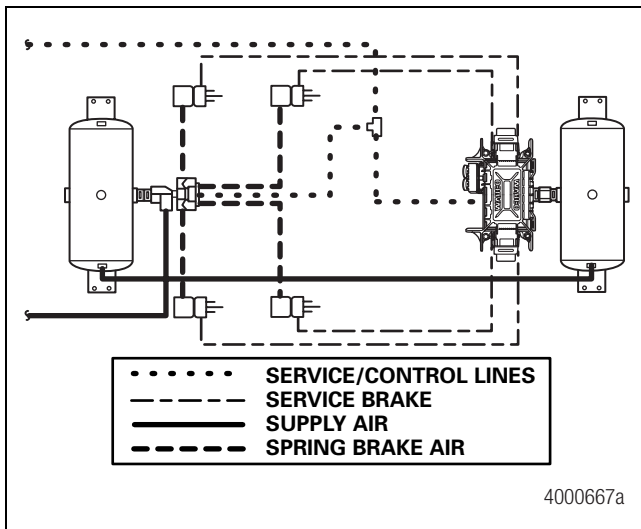

Figure 20

4. Plug any unused delivery ports. Apply SAE-standard, DOT-approved Teflon tape or paste-type thread sealant to all pipe threads beyond the first two threads. Pipes with pre-applied thread sealant may also be used.

Install the Power Cable

1. Connect the power cable to the ECU/single modulator valve assembly using the Meritor WABCO power connector. Figure 21.

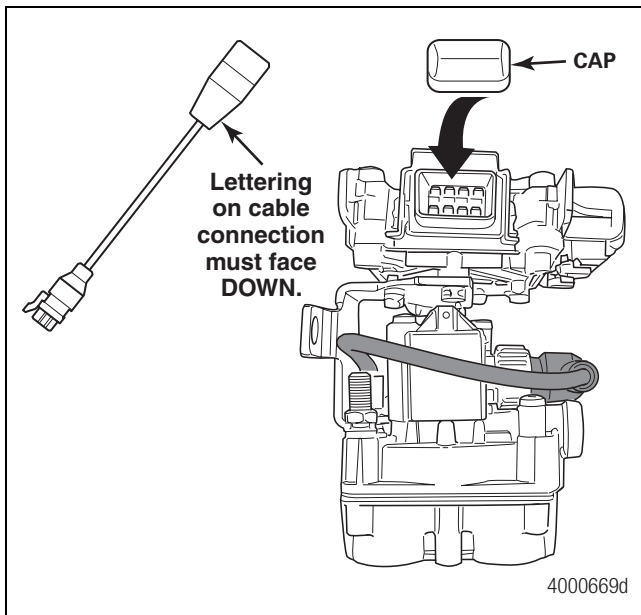

Figure 21

2. Connect the power cable to the vehicle's harness dropout using the standard Delphi Packard ABS connector.
3. Bundle any excess cable in a loop (bow tie) and secure it in the sub-frame of the vehicle or along the air hoses as appropriate.

Attach the Sensor Extension Cables to the ECU/Valve Assembly

1. Remove the protective caps from YE2 and YE1 sensor connectors on the ECU/modulator valve assembly. Figure 22.

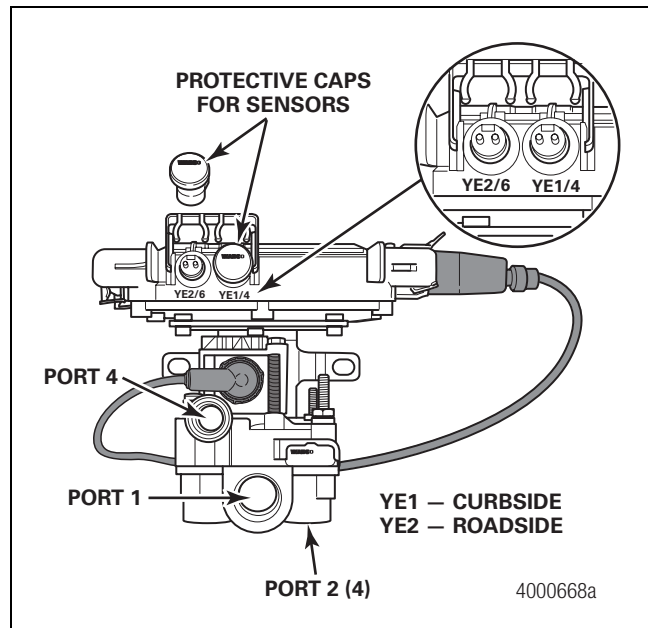

Figure 22

2. Plug the sensor extension cable into the sensor connectors on the ECU/single modulator valve assembly. To secure the connection, push the sensor retainer clip down. The retainer clips must fit in the groove of the sensor connectors to ensure correct connection.
 - A. Connect curbside sensor at YE1
 - B. Connect roadside sensor at YE2
3. Route the sensor extension cable to the frame rail. Be sure to route the cable in a way that will prevent pinching or chafing and will allow sufficient movement for suspension travel.

Install the Wheel Speed Sensors on the Trailer Axles

1. Apply the Meritor WABCO lubricant included in the replacement kit to the sensor spring clip, sensor and in the bore of the sensor mounting block. This is the bore where the spring clip and sensor will be installed.

NOTE: Use Meritor WABCO spring clips to ensure a correct fit.

2. Push the spring clip into the sensor holder from the inboard side until the spring clip tabs are against the sensor holder.

NOTE: After installation, there should be no gap between the sensor and the tone ring. During normal operation, a gap of up to 0.04-inch (6.35 mm) is allowed.

- Push the sensor completely into the sensor spring clip until it contacts the tone ring. Figure 23.

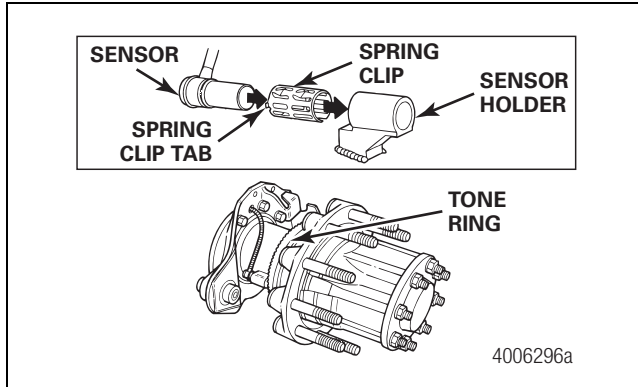

Figure 23

- Use a clean, soft rag to wipe any excess lubricant from the back and front of the sensor.

CAUTION

Do not overtighten tie wraps on a cable. Overtightening can damage the cable. Do not tie wrap the molded sensor plug. The sensor extension cable must follow the brake hose to the ECU/valve assembly to allow for axle jounce and rebound.

NOTE: Brake hose clips with a provision for the sensor extension cable are recommended. Do not use tie wraps. Meritor WABCO does not supply brake hose clips.

- Route the sensor cable toward the brake chamber, either over the brake spider or through the pre-stamped hole dedicated to ABS sensors. Route to the back side of the axle. Use black tie wraps to secure the cable to the axle between the brake spider and the suspension brackets. Continue to route the sensor cable behind the spring seats. Secure the cable to the axle one inch from the molded sensor plug. Figure 24.

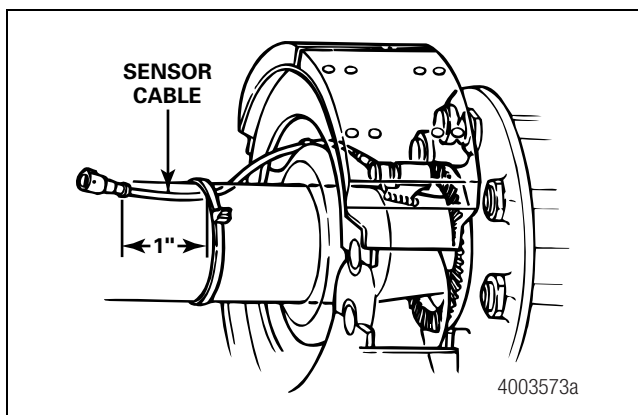

Figure 24

- Install the wheel hub carefully so that the tooth wheel pushes against the sensor as the wheel bearings are adjusted. There should be no gap between the sensor and the tooth wheel.
- Install the fasteners that hold the sensor cable in place, supporting the cable every 8 to 12-inches (203-304 mm). Excess cable should be secured lengthwise in the frame rail. Do not coil excess cable.
- Install the brake drum on the wheel hub.
- Test the sensor output voltage. Use a volt/ohm meter to check the output voltage of the sensors while rotating the wheel at approximately 1/2 revolution per second. Minimum output must be 0.2 volt AC. If minimum output is less than 0.2 volt AC, push the sensor toward the tooth wheel. Recheck the sensor output.
- Adjust the trailer axle brakes per the trailer manufacturer's specifications.
- Remove the block and safety stands.

Enhanced Easy-Stop™ Blink Code Diagnostics

Meritor WABCO recommends using TOOLBOX™ Software version 7.0 or higher to troubleshoot Enhanced Easy-Stop™ Trailer ABS. If TOOLBOX™ Software is not available, you can use blink code diagnostics. The new ECU does not have an LED on top of the ECU, but blink codes are easily displayed on the ABS indicator lamp mounted on the side of the trailer. Refer to Maintenance Manual MM-0180, Enhanced Easy-Stop™ Trailer ABS, for more information about diagnostic procedures, including blink code diagnostics.

NOTE: A copy of the technical publication TP-0173 is included in this replacement kit. This document details the Meritor WABCO blink codes and resolutions for these instances as well as service part number information for the ABS components.

Diagnostics can be located utilizing a combination power/diagnostic "Y" style cable, part number 449 364 153 0, that plugs directly into the ECU/modulator valve assembly. This cable allows for the use of TOOLBOX™ Software and other diagnostic options. TOOLBOX™ Software is available from SPX at 800-328-6657. Figure 25.

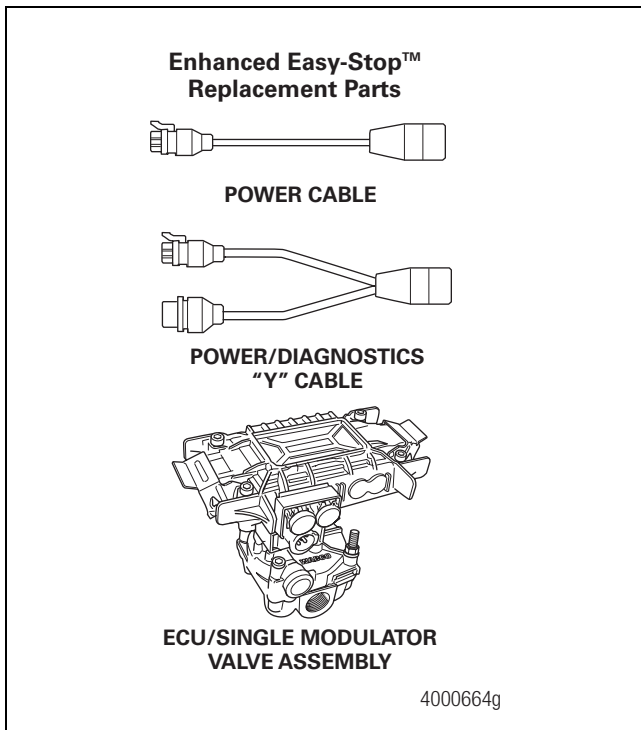

Figure 25

End of Line Testing

Testing is required on all Enhanced Easy-Stop™ installations. To run these tests, Meritor WABCO recommends you use TOOLBOX™ Software version 7.0 or higher. If TOOLBOX™ cannot be used, the general test procedures are called out in the section titled “End of Line Testing without TOOLBOX™ Software.”

If you are using a Pro-Link, refer to the operating manual for test instructions.

Enhanced Easy-Stop™ 2S/1M Basic Installation — End of Line Testing Procedure Using TOOLBOX™ Software

If you are testing an installation that has a power only cable, temporarily install a Meritor WABCO combination power/diagnostics “Y” style cable.

1. Connect the diagnostic connector on the cable to the PC serial port/SAE diagnostic interface (J1587/J1708 to RS232 interface).

Refer to the Software Owner’s Manual, TP-99102, for instructions for running TOOLBOX™ Software.

2. Display the **Trailer ABS Main Screen**.
3. Verify the power supply.
 - Apply 12 volts DC to the blue wire (constant). Check the screen for the correct voltage (9.4 to 14 volts). Constant power voltage is displayed in the PRIMARY field. Figure 26.

- Apply 12 volts DC to the red wire (stoplight power). Check the screen for the correct voltage (9.4 to 14 volts). Stoplight power voltage is displayed in the SECONDARY field. Figure 27.

The INTERNAL field is not applicable to this test.

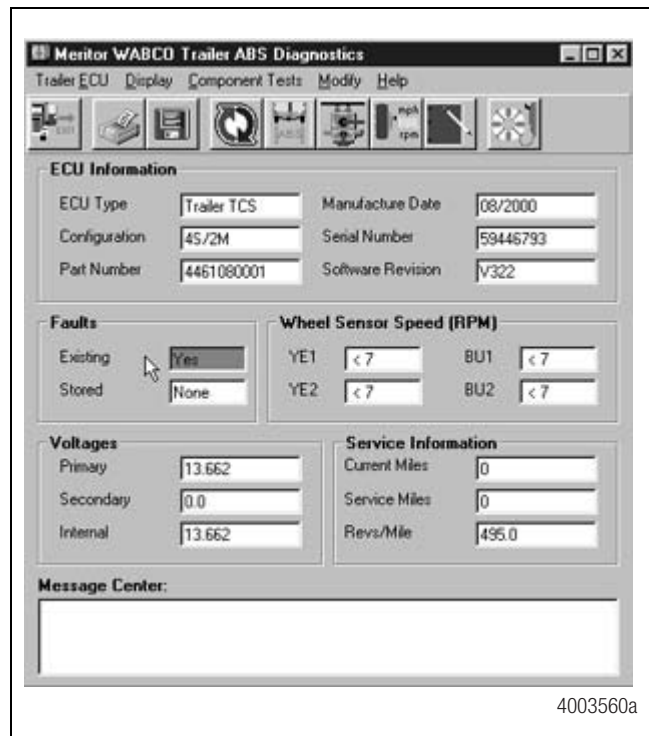

Figure 26

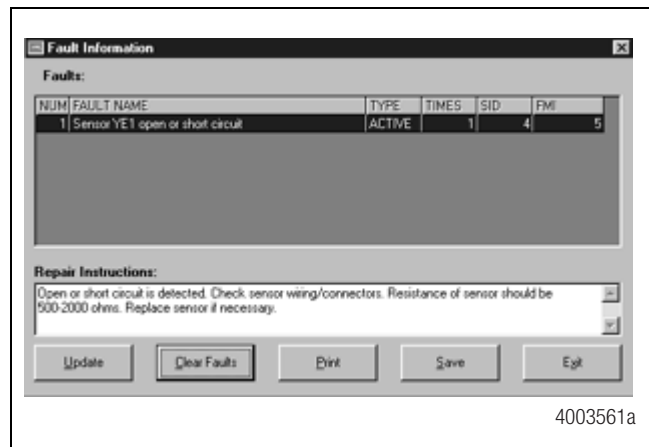

Figure 27

4. Check the Faults field on the Main Screen.
 - NONE** = No faults present, proceed with end of line test.

YES = Faults present, double-click on “YES” to bring up the fault information screen.

Use the information in the **Repair Instructions** field to perform the necessary repairs.

Verify Correct Valve and Lamp Installation

To verify valve and lamp installations with TOOLBOX™ Software:

1. At the **Trailer Main Screen**, click on **Component Test**, then select **Valves/Lamp** to display the **Valve Activation Screen**. Figure 28.

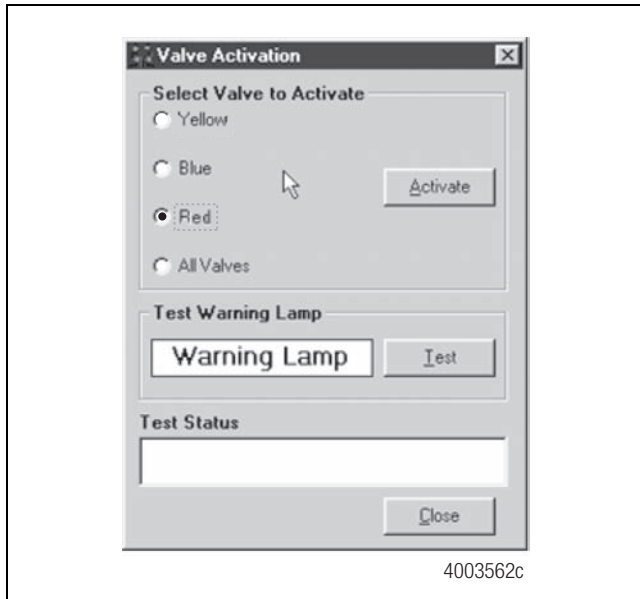

Figure 28

2. The Red valve indicator will be selected. Click on the **Activate** button and listen for the valve to click, indicating a good installation. The **Test Status** box at the bottom of the menu will also display the status of this test.
3. Click on the **Test** button to activate the ABS indicator lamp — this is the lamp that is mounted on the side of the trailer. The lamp will flash eight times, indicating lamp installation is OK. The **Test Status** box at the bottom of the menu will also display the status of this test.
4. Click on **Close** to exit.

Sensor Orientation Test

The sensor orientation test must be performed as part of the end of line testing procedure.

Sensor Orientation Test Screen

Before beginning this test, look at the ECU to see if the wheel end sensors face the front or rear of the trailer. TOOLBOX™ will ask for this information to start the test (Step 5). To perform the sensor orientation test:

1. Raise the sensed wheel ends off the ground.
2. Apply air to the emergency line to fill the air tanks and release the spring brakes so that the wheels can be rotated.
3. Apply 12 volts DC to the ABS.

4. At the **Trailer Main Menu**, click on **Component Test**, then select **Sensor Orientation Test** to display the **Sensor Orientation Test** screen. Figure 29.

When the **Sensor Orientation Test** screen first appears, the **Sensors Facing** field will display the default — **Front**. This will occur regardless of the actual sensor orientation of the installation being tested.

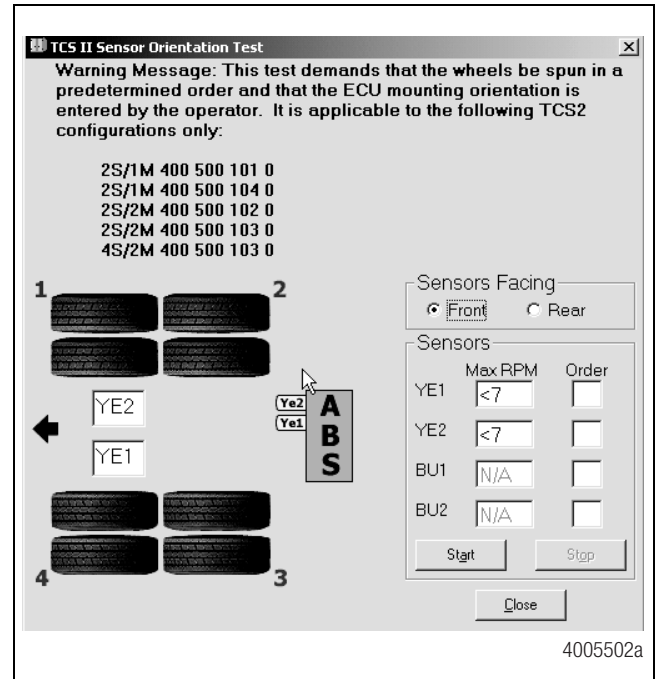

Figure 29

5. Click on **Front** or **Rear** in the **Sensors Facing** field to select the mounting orientation of the ECU/single modulator valve assembly.

Refer to Figure 29 and Figure 30 for illustrations of the ECU mounted with sensors facing forward and rear. The correct mounting orientation must be selected prior to starting the test.

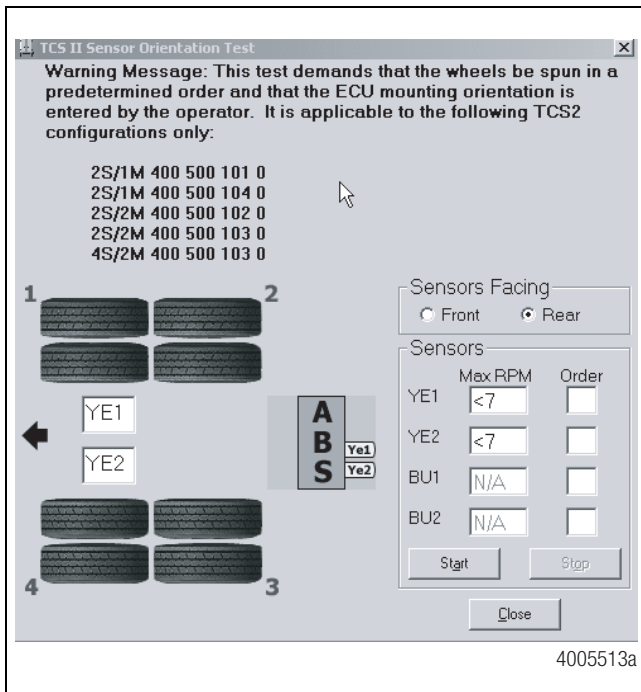

Figure 30

6. Click on **Start** to begin the test. Figure 31.

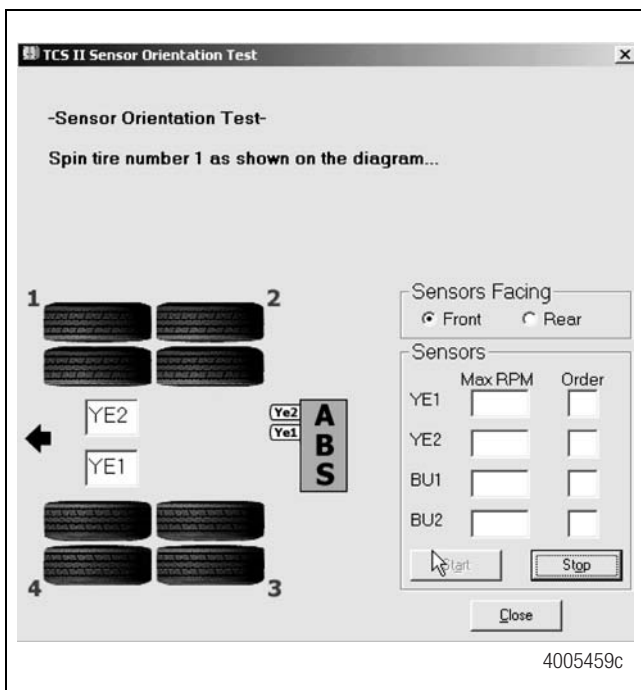

Figure 31

7. Follow the screen prompts, starting with 1, to rotate each sensed wheel end at a rate of 1/2 revolution per second. This rate equals a wheel speed of approximately 4 mph (7 kph). As each sensed wheel is rotated, check the color of the sensor identification block on the screen for results. Sensor identification is indicated in the boxes located in the bottom left portion of the **Sensor Orientation Test** screen. Figure 30.

Green background: Correct sensor location. Spin the next sensed wheel as indicated by the screen prompt.

Red background: Incorrect sensor location. Stop the test (click on **Stop**). Reinstall the sensors per the instructions on page 10, Attach the Sensor Extension Cables to the ECU/Valve Assembly. Repeat Steps 3 through 6.

8. To finish the Sensor Orientation Test, click on **Stop**, then on **Close**.

9. Verify there is sensor output. If there is no sensor output, verify that a tone ring has been installed and that the sensor is pushed all the way in against the tone ring. Repeat the test. If the problem persists, contact Meritor WABCO (800-535-5560). Sensor output appears in the Sensors field located in the bottom right portion of the **Sensor Orientation Test** screen. Figure 30.

End of Line Testing without TOOLBOX™ Software

1. Apply 12 volts DC power to the ABS.
2. The ECU/modulator valve assembly should click two times.
3. Observe the ABS indicator lamp:

If the ABS indicator lamp **comes on** for three seconds and **goes out**, the installation is correct. The end of line test is complete.

If the ABS indicator lamp **comes on** and **stays on**, check the sensor installation:

- A. Remove the power from the ABS and raise the sensed wheels so that they may be rotated.
- B. Repeat Step 1 and Step 2.
- C. Rotate the sensed wheel ends at a rate of 1/2 revolution per second. This rate equals a wheel speed of approximately 4 mph (7 kph).

The ABS indicator lamp should now go out and stay out indicating a correct installation. The end of line test is complete.

4. If the ABS lamp **does not** go out, there is a sensor gap problem or hardware fault. Adjust the sensor according to the Sensor Gap Adjustment procedures. If necessary, perform a fault code check. Refer to Table C.

Fault Code Check

Use constant power activation to perform the fault code check, as follows:

1. Apply constant power to the ECU/modulator valve assembly **for more than one, but less than five seconds.**
2. Remove power.
3. Reapply power.
4. Check the trailer ABS indicator lamp on the side of the trailer. The fault code will be displayed three times.
5. Find the fault in Table C and make the necessary repairs.
6. After marking the necessary corrections, repeat the end of line test to verify correct sensor installation.

NOTE: Refer to Maintenance Manual MM-0180, Enhanced Easy-Stop™ Trailer ABS with PLC, for repair instructions.

Table C: Blink Code Chart

Blink Code	Problem Area	Action
4	Sensor YE1 (curbside sensor)	Check sensor installation. Make necessary repairs.
6	Sensor YE2 (roadside sensor)	Check sensor installation. Make necessary repairs.
7	ECU/single modulator valve assembly	Verify correct installation. If code continues, contact Meritor WABCO for assistance.
14	Power Supply	Verify correct electrical installation. Check power supply. Make necessary corrections.
15	ECU Failure	Verify correct installation. If code continues, contact Meritor WABCO for assistance.
16	SAE J1708 Failure	Internal failure, contact Meritor WABCO.
17	SAE J2497 Failure	Internal failure, contact Meritor WABCO.
18	Generic I/O Failure	Verify correct electrical installation. Check power supply. Make necessary corrections.

Sensor Gap Adjustment

Push the sensor into its holder until it contacts the tone ring. At installation there must be no gap between the sensor and the tone ring.

Measure the AC voltage output. The value should be 0.2 volt AC when the wheel is rotated at a rate of 1/2 revolution per second.

Make necessary repairs.

Repeat the end of line test. If the trailer lamp still does not go out, a system fault exists. Perform a fault code check.

Trailer Identification (Required by Federal Motor Vehicle Safety Standard 121)

NOTE: The ABS indicator must be attached to the trailer.

After ensuring the Enhanced Easy-Stop™ trailer ABS has been correctly installed, attach the ABS indicator label included with the ECU/single modulator valve assembly to the trailer. Generally, this will be applied near the ABS trailer indicator lamp. Figure 32. Refer to the vehicle specification sheet for the correct location.

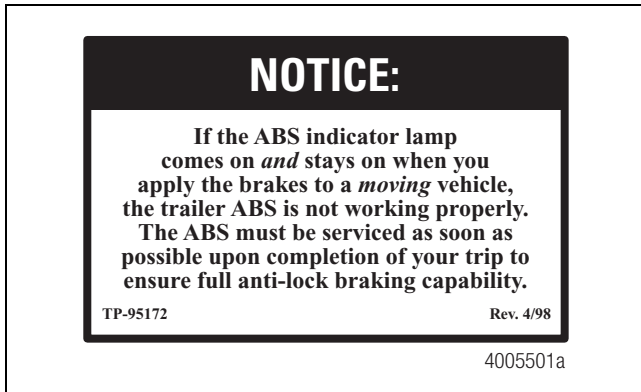

Figure 32

If this label is not included with the assembly, let your supervisor know. Labels are available from Meritor WABCO. Ask for part number TP-95172.

For additional assistance, contact Meritor WABCO at 800-535-5560.

Special Tools

Sensor Mounting Block Fixture	Part Number	Supplier
Meritor TP/WP	S100 100 101 0	Meritor

Press Plug Drive Adaptors	Part Number	Supplier
Meritor WP	51011-07	Meritor
Drive Handle	51011-10	Meritor

Spindle Bore Polishers	Part Number	Supplier
Meritor TP/TB/WP	3T534	Grainger

Specialty Tools and Supplies	Part Number	Supplier
Slide Hammer Kit	81044-00	Meritor
Spindle End Plug Removal Spear	81044-01	Meritor
Bore Polishing Mandrel	3T564	Grainger
Sensor Tester	J-42883	SPX

Cleaning Wand

Refer to Figure 33 to make a cleaning wand.

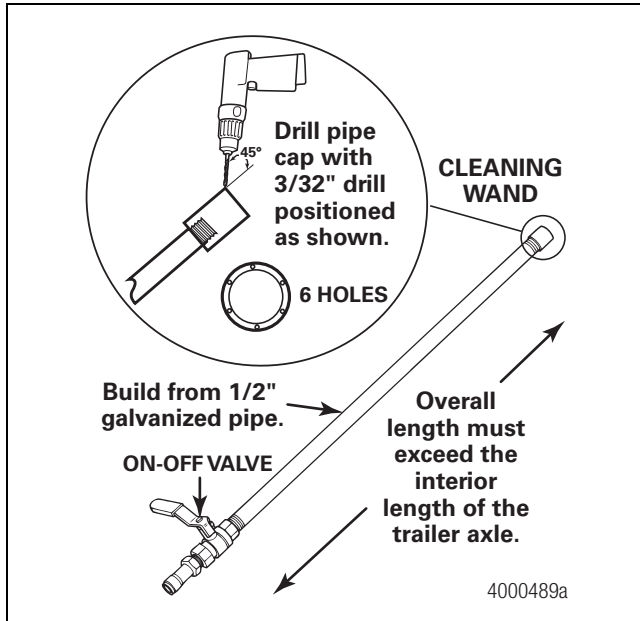

Figure 33

MERITOR WABCO

Meritor WABCO Vehicle Control Systems
2135 West Maple Road
Troy, MI 48084-7121
800-535-5560
meritorwabco.com

Information contained in this publication was in effect at the time the publication was approved for printing and is subject to change without notice or liability. Meritor WABCO reserves the right to revise the information presented or to discontinue the production of parts described at any time.

Copyright 2007
ArvinMeritor, Inc.
All Rights Reserved

Printed in USA

TP-06110
Issued 01-07
(16579/22882)