

Transfer Case T-223 Series

Maintenance Manual 3A

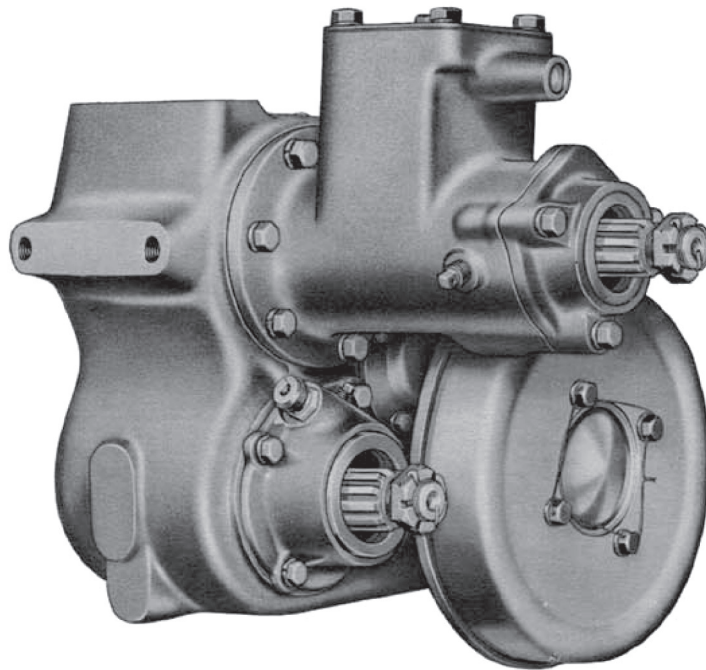

"Clover Leaf" Four-Shaft Design

MERITOR TRANSFER CASES

FUNCTION AND DESIGN

A transfer case is a gear box located between the main transmission and the rear axle. Its purpose is to transfer power from the transmission to the front driving axles as well as the rear driving axles; it also provides an extra gear reduction (Lo) in the power train of the vehicle. The drop box design enables the front axle drive line to clear the underside of the engine.

All Meritor Transfer Cases incorporate the counter shaft design; each shaft is mounted on roller or ball bearings.

Most units are available with a Power Take Off and a parking brake as shown on the opposite page. Every unit incorporates a Front Axle Declutch, which is used to drive the front axle whenever the vehicle encounters steep grades or rough terrain. These accessories are actuated by separate shift levers located in the cab of the vehicle.

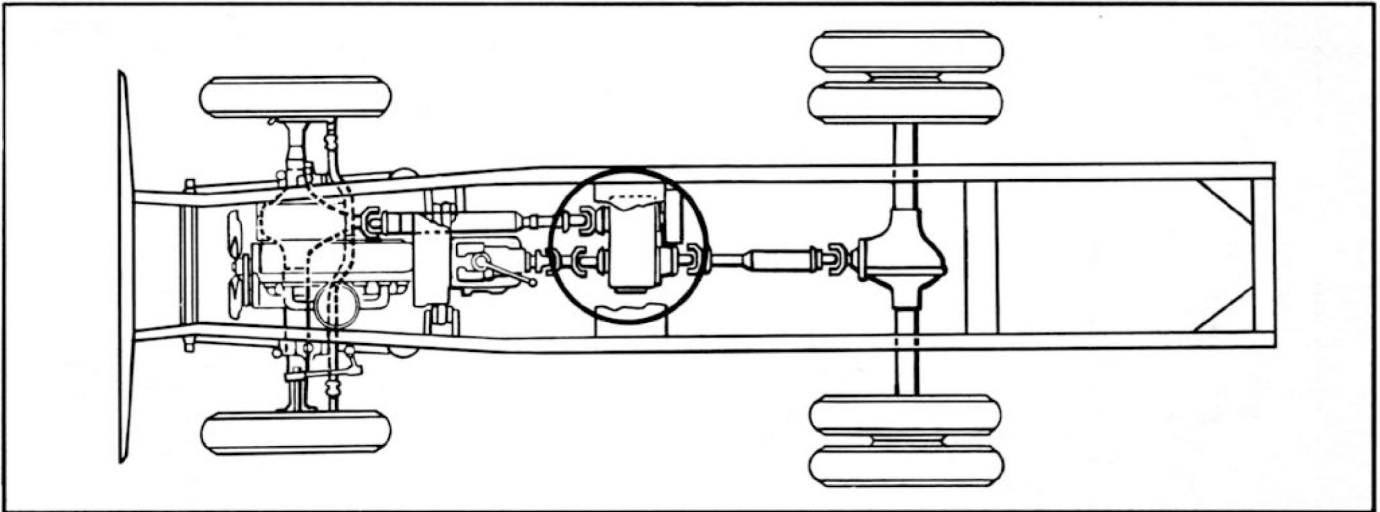

TYPICAL 4 x 4 HOOK-UP

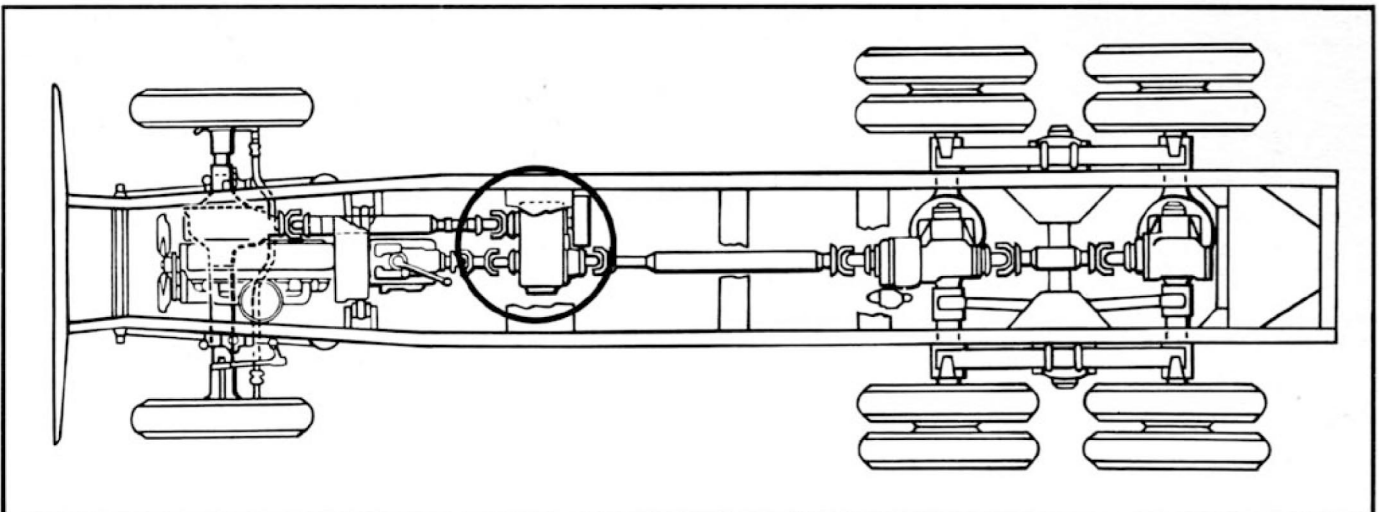

TYPICAL 6 x 6 HOOK-UP

"CLOVER LEAF" FOUR SHAFT DESIGN

The "Clover Leaf" Type Transfer Case is the two-speed, four shaft design that can be adapted to incorporate a power take off and mechanical type auxiliary brake as optional equipment.

EXPLODED VIEW — LESS POWER TAKE OFF

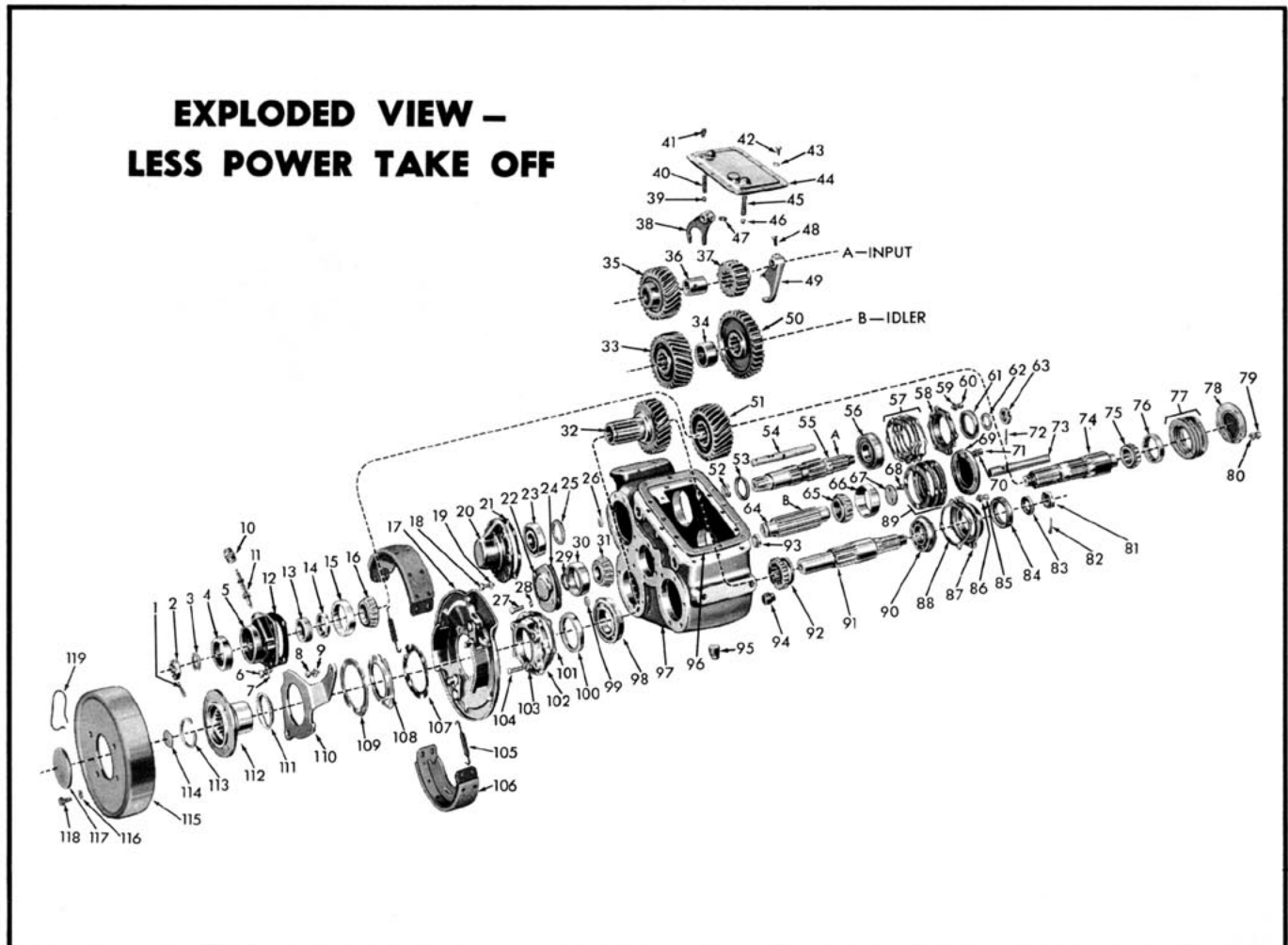

- | | | |
|--|------------------------------------|--------------------------------------|
| 1. Cotter key | 16. Rear output shaft rear bearing | 35. Direct drive gear |
| 2. Nut | 17. Brake backing plate | 36. Direct drive gear bushing |
| 3. Washer | 18. Cap screw | 37. Low speed sliding gear |
| 4. Oil seal | 19. Lock washer | 38. Range shift fork |
| 5. Rear output shaft rear bearing cap | 20. Input shaft rear bearing cage | 39. Detent ball |
| 6. Cap screw | 21. Gasket | 40. Detent spring |
| 7. Lock washer | 22. Idler shaft rear bearing cap | 41. Breather |
| 8. Cap screw | 23. Input shaft rear bearing | 42. Cap screw |
| 9. Lock washer | 24. Gasket | 43. Washer |
| 10. Speedometer driven gear bushing | 25. Spacer | 44. Housing cover |
| 11. Speedometer driven gear and shaft | 26. Shift shaft hole plug | 45. Detent spring |
| 12. Gasket | 27. Cap screw | 46. Detent ball |
| 13. Speedometer drive gear | 28. Lock washer | 47. Shift fork set screw |
| 14. Spacer | 29. Snap ring | 48. Shift fork set screw |
| 15. Rear output shaft rear bearing cup | 30. Idler shaft rear bearing cup | 49. Front axle declutch shift fork |
| | 31. Idler shaft rear bearing | 50. Idler shaft Lo gear |
| | 32. Front output gear | 51. Rear output shaft gear |
| | 33. Idler shaft Hi gear | 52. Shift shaft oil seal |
| | 34. Gear spacer | 53. Direct drive gear spacing washer |

- | | | |
|---|---|--|
| 54. Range shift shaft | 77. Shims | 98. Front output shaft rear bearing (with snap ring) |
| 55. Input shaft | 78. Rear output shaft front bearing cap | 99. Shift shaft hole plug |
| 56. Input shaft front bearing | 79. Cap screw | 100. Oil seal |
| 57. Shims | 80. Lock washer | 101. Gasket |
| 58. Input shaft front bearing cap | 81. Nut | 102. Front output shaft rear bearing cap |
| 59. Lock washer | 82. Cotter key | 103. Washer |
| 60. Cap screw | 83. Washer | 104. Cap screw |
| 61. Oil seal | 84. Oil seal | 105. Brake shoe return spring |
| 62. Washer | 85. Cap screw | 106. Brake shoe |
| 63. Nut | 86. Lock washer | 107. Gasket |
| 64. Idler shaft | 87. Front output shaft front bearing cap | 108. Oil deflector |
| 65. Idler shaft front bearing | 88. Gasket | 109. Washer |
| 66. Idler shaft front bearing cup | 89. Shims | 110. Brake lever |
| 67. Bearing retainer plate | 90. Front output shaft front bearing (with snap ring) | 111. Oil baffle |
| 68. Cap screw | 91. Front output shaft | 112. Brake hub |
| 69. Idler shaft front bearing cap | 92. Declutch collar | 113. Snap ring |
| 70. Lock washer | 93. Shift shaft oil seal | 114. Small expansion plug |
| 71. Cap screw | 94. Oil filler plug (some units employ elbow arrangement) | 115. Brake drum |
| 72. Cotter key | 95. Drain plug | 116. Lock washer |
| 73. Declutch shift shaft | 96. Cover to housing gasket | 117. Large expansion plug |
| 74. Rear output shaft | 97. Transfer case housing | 118. Cap screw |
| 75. Rear output shaft front bearing | | 119. Lock wire |
| 76. Rear output shaft front bearing cup | | |

SECTIONAL VIEW – WITH POWER TAKE OFF

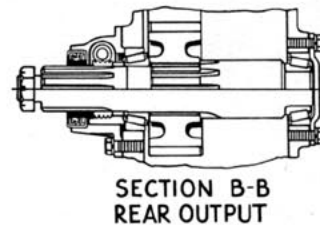
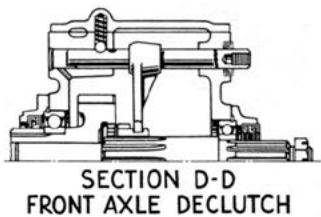
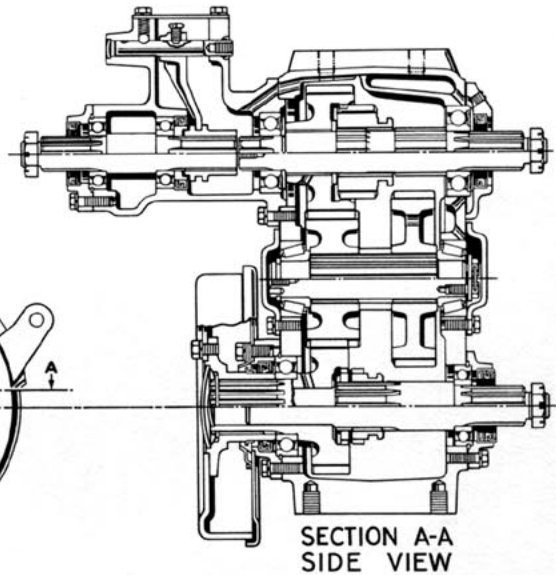
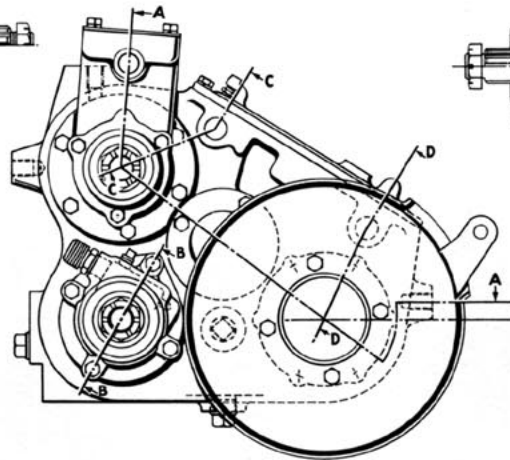
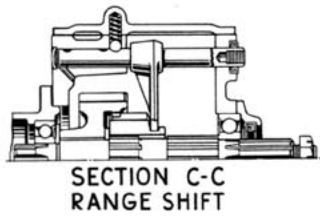

REMOVAL AND DISASSEMBLY

- A. After removing the unit, thoroughly clean the exterior portion before proceeding with the disassembly.
- B. Remove the drain plug from the bottom of the unit and drain the oil.

DISASSEMBLY

- A. Remove the nuts and take off all yokes or flanges.

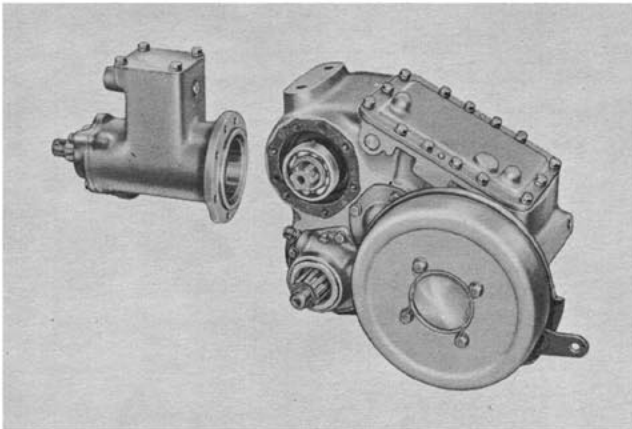

- B. Remove the cap screws and lock washers and pull off the power take off assembly (or rear cover if P.T.O. is not used).

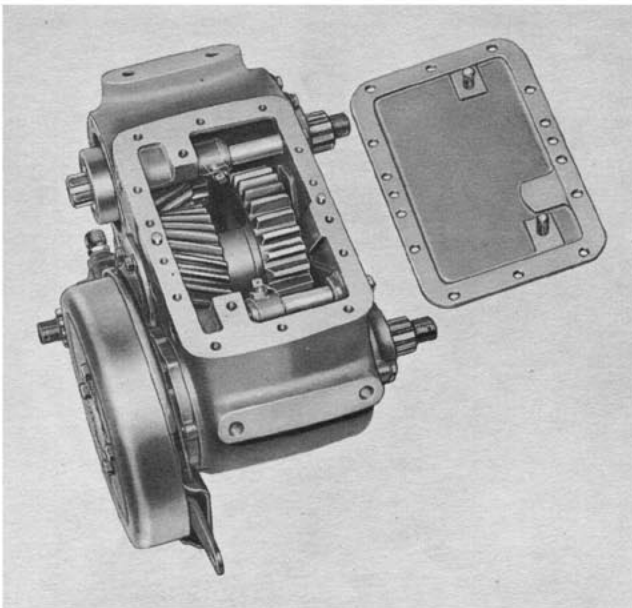

- C. Remove the cap screws and lock washers and lift off the cover and gasket.
- D. Remove the detent balls and springs.

REMOVE SHIFT COMPONENTS

- A. Cut the lock wire and loosen the shift fork set screws.

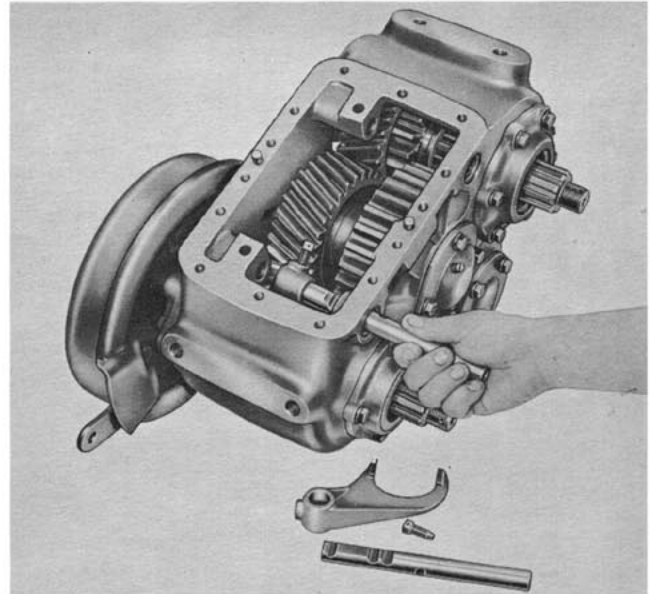

- B. Pull both shift shafts out through front of case if possible. Otherwise, use a soft metal drift and drive the shafts and expansion plugs out through the rear of the case.
- C. Remove the oil seals from front of case if necessary.
- D. Lift out the range shift fork and the declutch fork.

REMOVE FRONT OUTPUT SHAFT

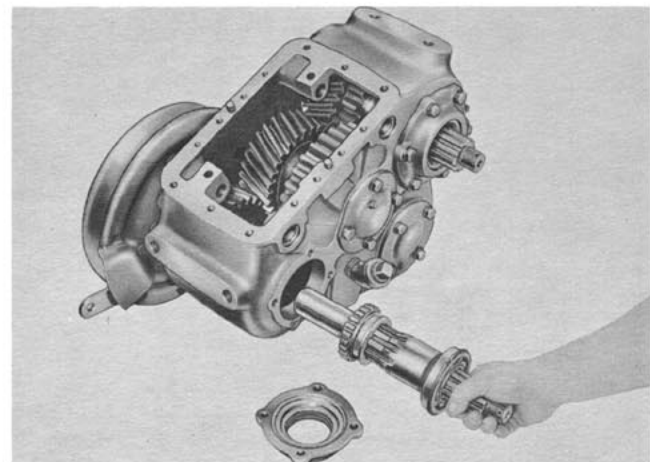

- A. Remove the front output shaft bearing cap and gasket. Pull the shaft and declutch collar from the case.

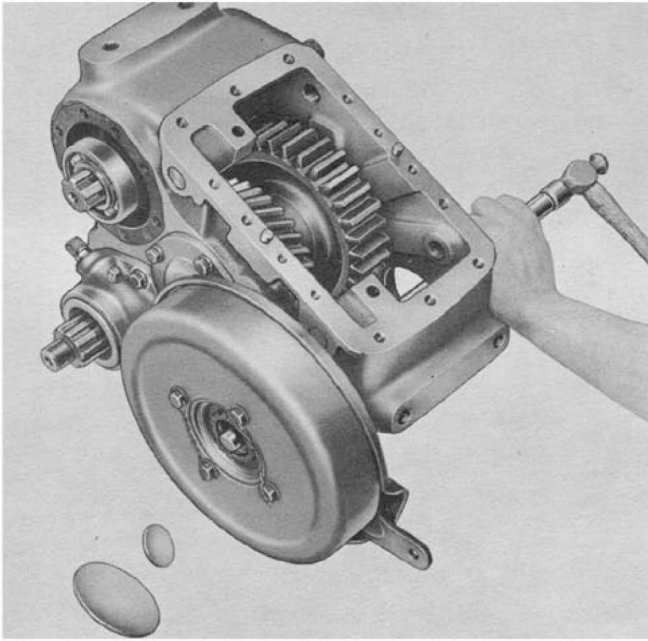

B. Slide a bar through the front output shaft gear and tap out the small and large expansion plugs located in the brake section.

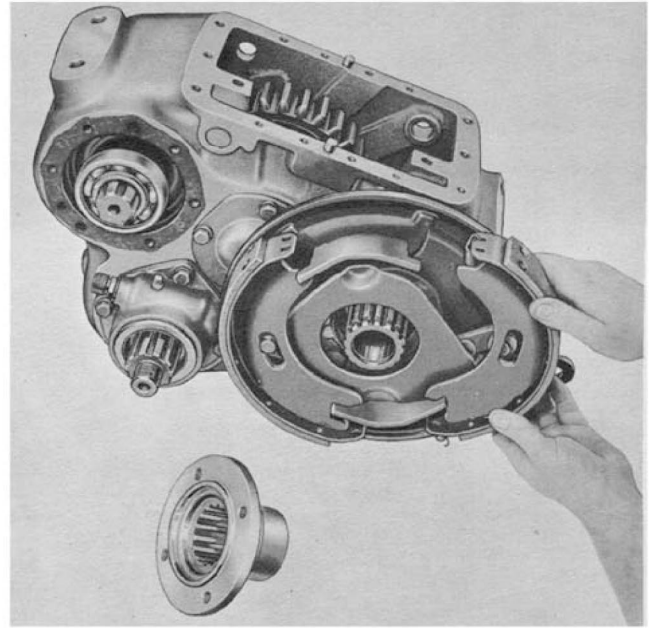

D. Unhook the brake shoe return springs. Remove the brake shoes and the lever.

REMOVE THE PARKING BRAKE ASSEMBLY

A. Cut the lock wire and remove the cap screws from the brake drum. Take off the drum.

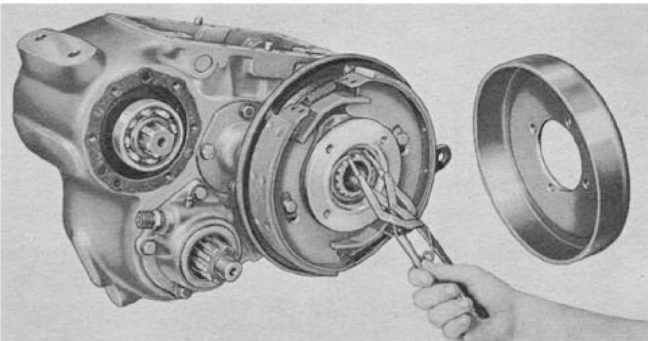

B. Remove the brake hub retaining ring.

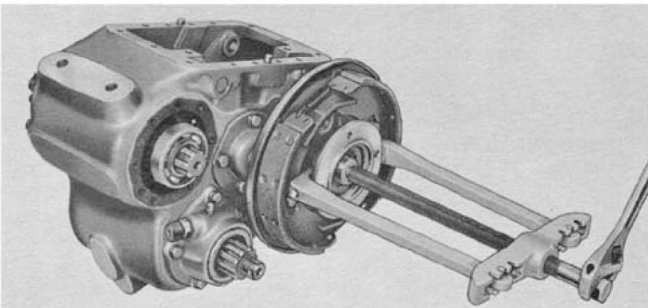

C. Remove the hub with a suitable puller.

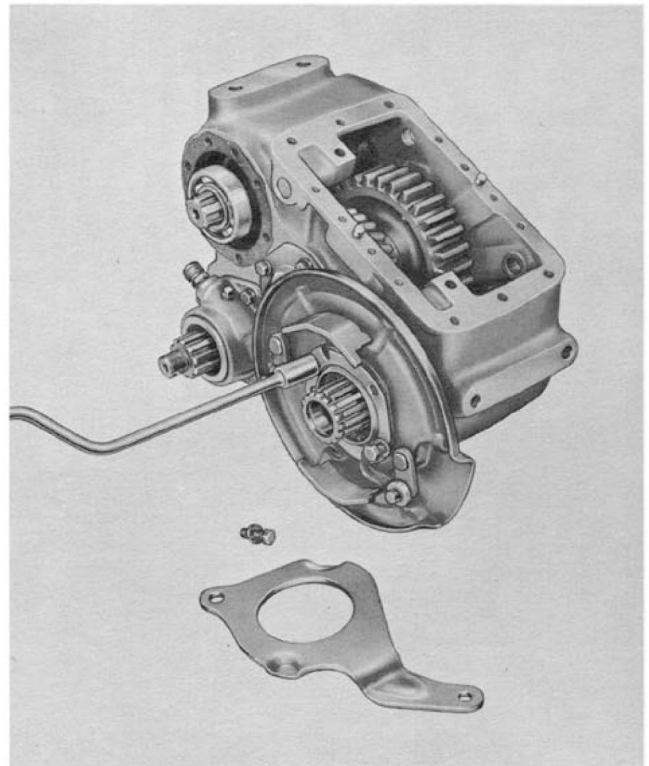

E. Remove the mounting bolts and take off the backing plate assembly (with washer, deflector and gasket).

Additional information pertaining to the DLM type brake can be found in the Meritor Field Maintenance Manual No. 4, "Brakes."

REMOVE THE IDLER SHAFT ASSEMBLY

NOTE: *The front output gear cannot be removed with the idler assembly in position because the gears interfere with each other.*

- A. Remove the front and rear bearing caps. Wire the forward bearing cap shims together for re-assembly.

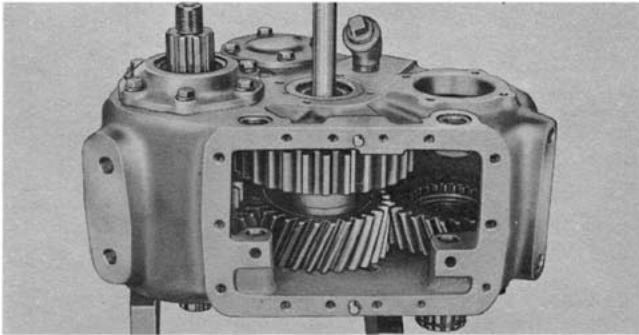

- B. Remove the bearing retainer plate from the front end of the idler shaft and then press the shaft out through the rear of the case.

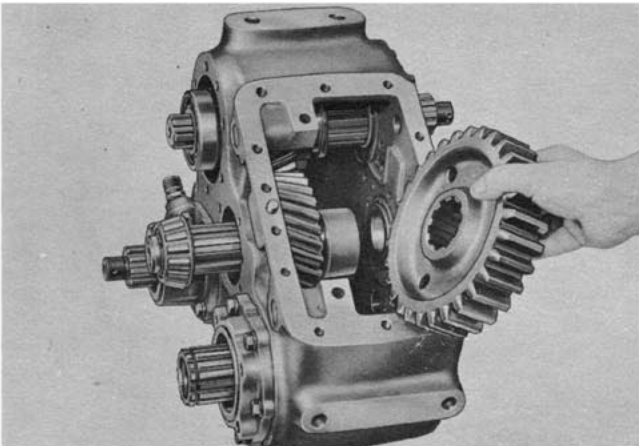

- C. Lift out the Lo gear, gear spacer and front bearing.

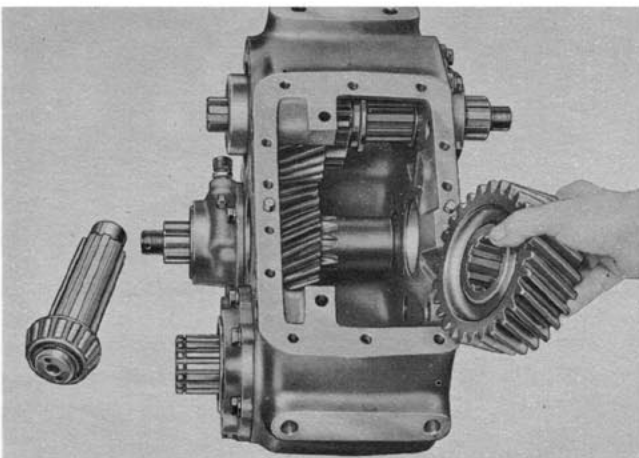

- D. Remove the Hi gear. Tap the front bearing cup from the case.
- E. Remove the snap ring and press the rear bearing from the idler shaft.

REMOVE FRONT OUTPUT GEAR

With the idler assembly removed, the front output gear and bearing can be removed:

- A. Remove the rear bearing cap and gasket.

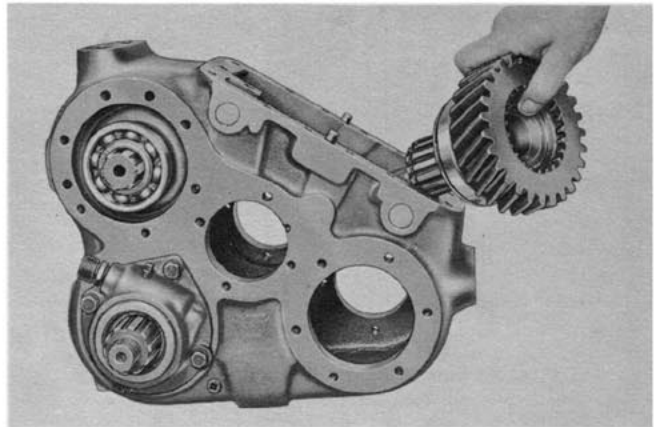

- B. Take off the bearing snap ring and tap the gear into the case; reach through the cover opening and lift out the gear and bearing.
- C. Press off the radial bearing.

REMOVE REAR OUTPUT SHAFT

- A. Remove the cap screws and take off the front and rear bearing caps. Wire the shims together for reassembly.

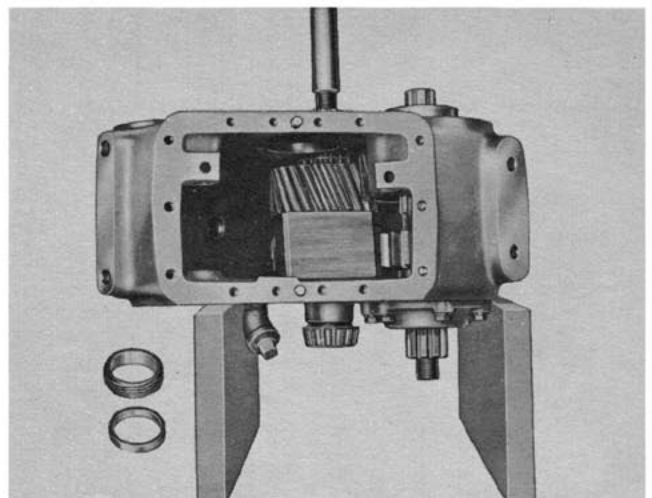

- B. Remove the speedometer drive gear and spacer.
- C. Block the gear with a piece of wood and press the rear output shaft and front bearing out of the case as shown. The gear and rear bearing can be lifted out through the cover hole.

REMOVE INPUT SHAFT

- A. Remove input shaft front bearing cover. Wire the shim pack together for reassembly.

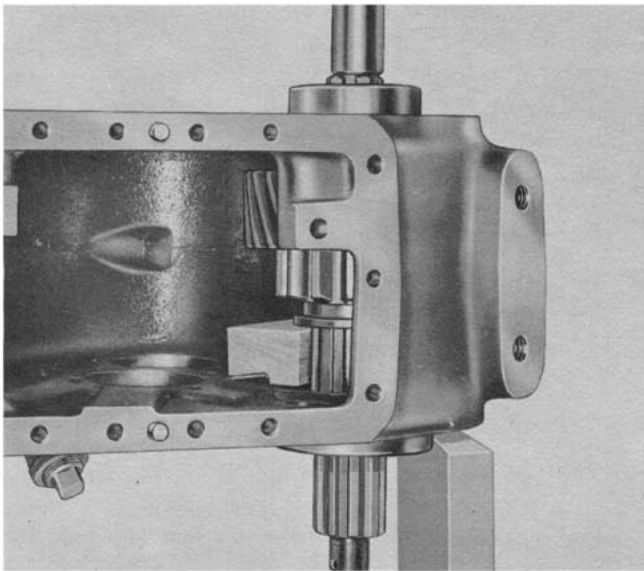

- B. Using a block of wood between the sliding gear and the case, press out the input shaft and front bearing. *Do not pound on the shaft if the gear becomes bound.*

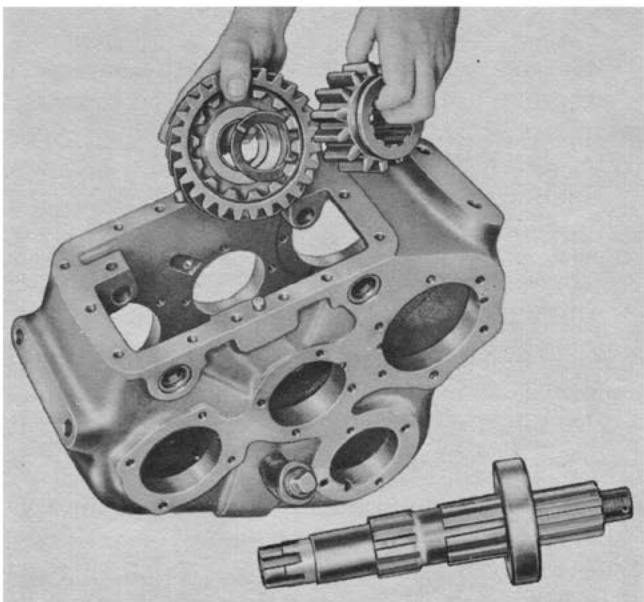

- C. Lift out the sliding gear, drive gear and spacer.
- D. Remove front bearing from shaft.

DISASSEMBLE POWER TAKE-OFF ASSEMBLY

- A. Remove cap screws and lock washers. Lift off the cover and gasket.
- B. Take out the detent spring and ball.
- C. Cut wire and loosen shift fork set screw.
- D. Tap the shift shaft out through the rear of housing (expansion plug will fall out).

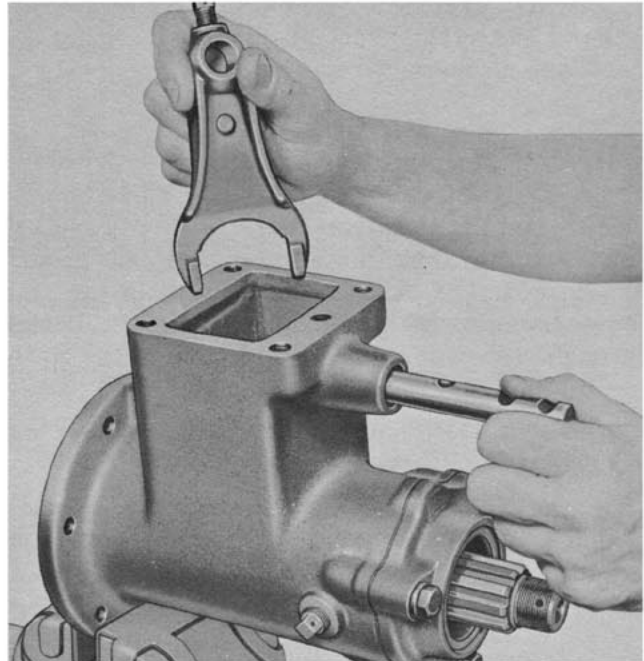

- E. Remove the shift shaft and the shift fork.
- F. Remove oil seal cage.

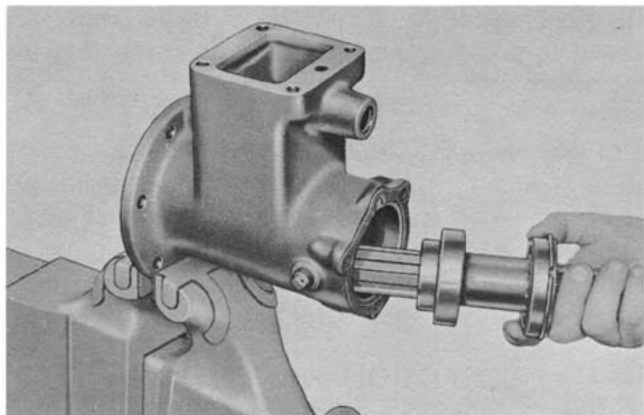

- G. Remove the sliding clutch and pull out the shaft assembly.
- H. Press bearings and wiper from shaft.
- I. If necessary, remove shift shaft oil seal as well as the oil seal located inside the housing.

PREPARE FOR REASSEMBLY

CLEAN, INSPECT AND REPAIR

Clean parts having ground and polished surfaces, such as gears, bearings and shafts, with solvent type cleaners such as emulsion cleaners, carbon tetrachloride or petroleum solvents excluding gasoline. Do not clean these parts in a hot solution tank or with water and alkaline solutions such as sodium hydroxide, orthosilicates or phosphates.

CAUTION: Exercise care to avoid skin rashes, fire hazards and inhalation of vapors when using solvent type cleaners.

ROUGH PARTS

Rough parts such as transfer case housings, accessory housings and some brake parts may be cleaned in hot solution tanks with mild alkali solutions providing these parts are not ground or polished. The parts should remain in the tank long enough to be thoroughly cleaned and heated through. This will aid the evaporation of the cleaning solution and the rinse water.

CAUTION: Exercise care to avoid skin rashes and inhalation of vapors when using alkali cleaners.

Parts cleaned in solution tanks or with alkali cleaners should be thoroughly rinsed after cleaning to remove all traces of alkali.

COMPLETE ASSEMBLIES

Completely assembled transfer cases may be steam cleaned, on the outside only, to facilitate initial removal and disassembly, providing all openings are closed. Breathers, vented shift units, and all other openings should be tightly covered or closed to prevent the possibility of water entering the assembly.

DRYING

Parts should be thoroughly dried immediately after cleaning. Use soft, clean, lintless absorbent paper towels or wiping rags free of abrasive material such as lapping compound, metal filings or contaminated oil. Bearings should never be dried by spinning with compressed air.

CORROSION PREVENTION

Parts that have been cleaned, dried, inspected and are to be immediately reassembled should be coated with light oil to prevent corrosion. If these parts are to be stored for any length of time, they should be treated with a good RUST PREVENTIVE and wrapped in special paper or other material designed to prevent corrosion.

INSPECT

It is impossible to overstress the importance of careful and thorough inspection of transfer case parts prior to reassembly. Thorough visual inspection for indications of wear or stress, and the replacement of such parts as are necessary will eliminate costly and avoidable drive unit failure.

- A. Inspect all bearings, cups and cones, including those not removed from parts of the transfer case, and replace if rollers or cups are worn, pitted or damaged in any way. Remove parts needing replacement with a suitable puller or in a press with sleeves. Avoid the use of drifts and hammers. They may easily mutilate or distort component parts.
- B. Inspect spur gears and clutches for wear or damage. Gears which are scored, pitted, ridged or worn should be replaced.

REPAIR

- A. Replace all worn or damaged parts. Hex nuts with rounded corners, all lock washers, oil seals and gaskets should be replaced at the time of overhaul.

Use only genuine Meritor-Standard replacement parts for satisfactory service. For example, using gaskets of foreign material generally leads to mechanical trouble due to variations in thickness and the inability of certain materials to withstand compression, oil, etc.

- B. Remove nicks, mars and burrs from machined or ground surfaces. Threads must be clean and free to obtain accurate adjustment and correct torque. A fine mill file or India stone is suitable for this purpose. Studs must be tight prior to reassembling the parts.
- C. When assembling component parts use a press where possible.
- D. Tighten all nuts to the correct torque. (See torque limits following service instructions.) Use soft iron locking wire to prevent possibility of wire breakage.
- E. The burrs, caused by lock washers, at the spot face of stud holes of cages and covers should be removed to assure easy reassembly of these parts.

ASSEMBLE POWER TAKE OFF UNIT

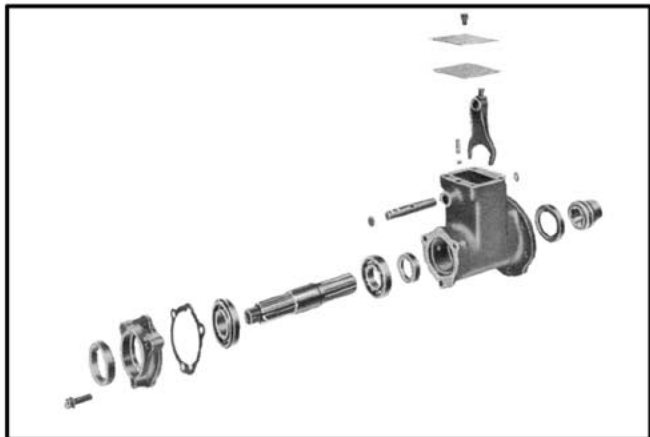

- A. Install the ball bearings on the power take off shaft.
- B. Position the wiper against the inner bearing. Install the snap ring in the groove of the outer bearing.

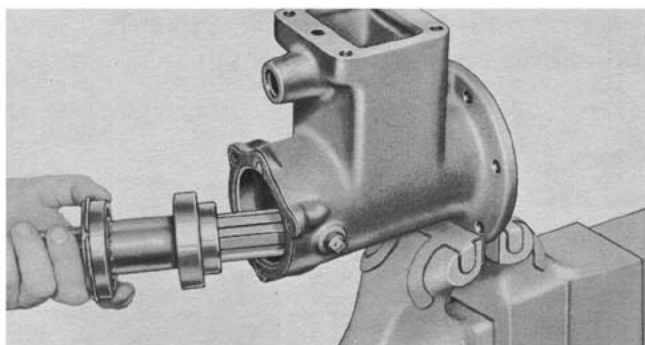

- C. Slide the shaft assembly into the housing and install the sliding clutch on the inner end.

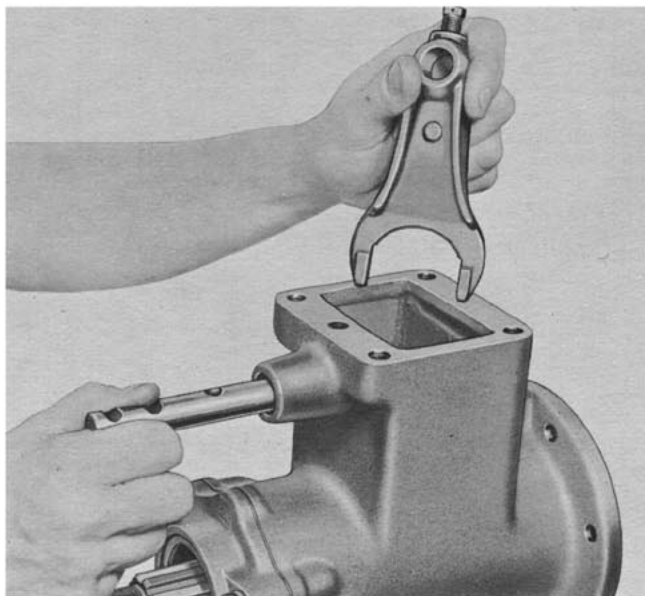

- D. Position a new gasket and install the oil seal cage assembly. Secure with cap screws and lock washers.
- E. Place the shift fork in the groove of the sliding clutch. Slide the shift shaft into the bore of the fork.
- F. Line up the recess in the shaft with the set screw and tighten the screw. Lock wire the set screw to the fork.
- G. Install expansion plug in the shift shaft hole.
- H. If necessary, replace shift shaft oil seal located in front of housing.

ASSEMBLE INPUT SHAFT



- A. Install the front bearing on the input shaft with shielded side against shoulder.
- B. Start the input shaft into the case. Mount the sliding gear, spacer and drive gear (with bushing) on the shaft.

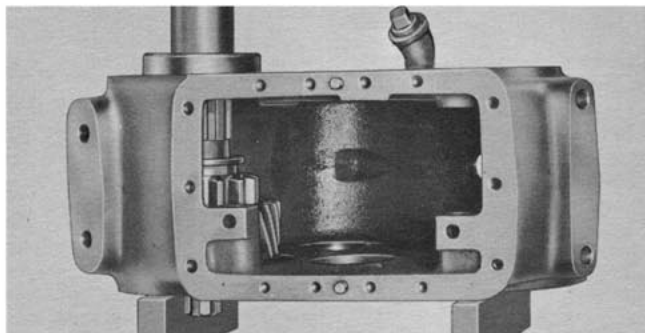

- C. Tap the input shaft into position using a suitable sleeve against the inner race of the front bearing.
- D. Position original shim pack plus .010" more to make sure there is endplay in the assembly. Install the front cover and tighten the cap screws.
- E. Place the thrust washer on the shaft and install the rear bearing with the shielded side toward the inside.
- F. Position a new gasket and attach the power take off (or cover, if used) to the rear of the case. Tighten the cap screws.

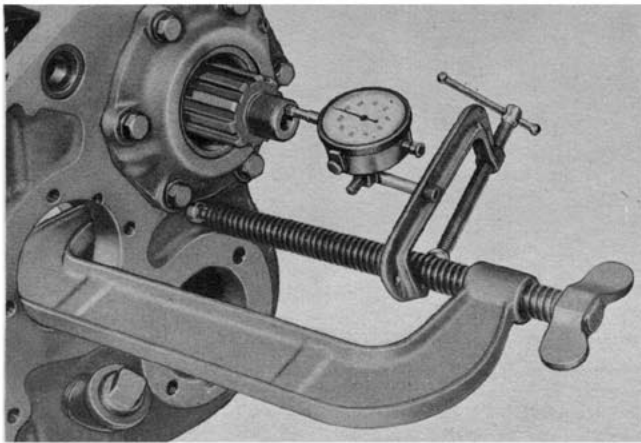

G. Mount a dial indicator on the unit. Set the stem against the front end of the input shaft and check the amount of endplay in the assembly. *Remove enough shims from under the bearing cap to arrive at an adjustment of .003"-.005" endplay.*

Reposition the bearing cap, insert cap screws and tighten to specified torque. Remove power take off for convenience in handling the transfer case.

C. Install the front bearing cup and the original shim pack plus .010". Install bearing cover, lock washers and tighten cap screws.

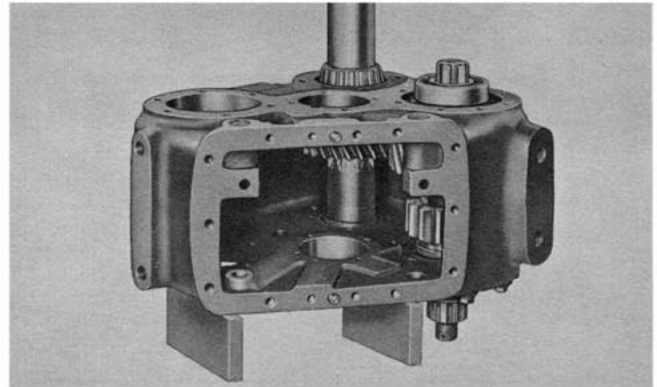

D. Press the rear bearing on shaft with a suitable sleeve. Then tap the bearing cup into position.

E. Install the spacer and speedometer drive gear over the shaft.

F. Position the new gasket, bearing cap (and oil seal) over the shaft. Install the lock washers and cap screws and tighten to specified torque.

INSTALL REAR OUTPUT SHAFT

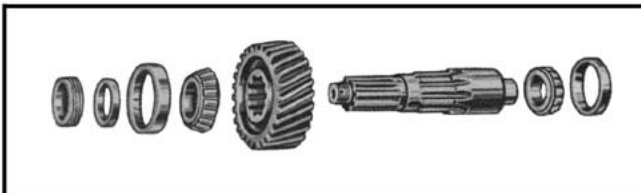

A. Press front bearing onto shaft with suitable sleeve.

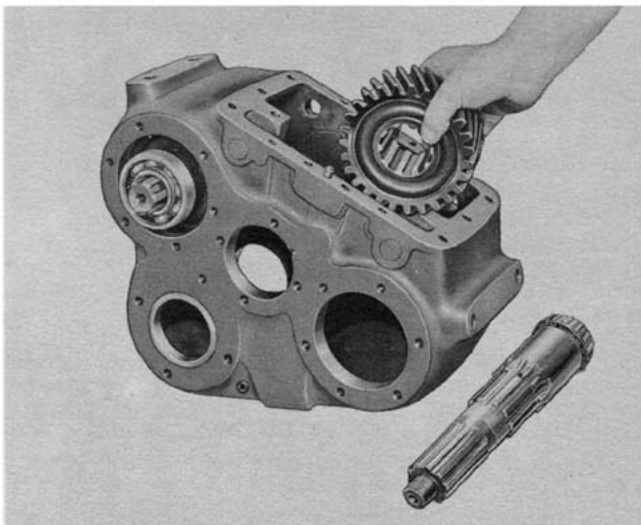

B. Hold the rear output gear in position inside the case and slide the shaft through it.

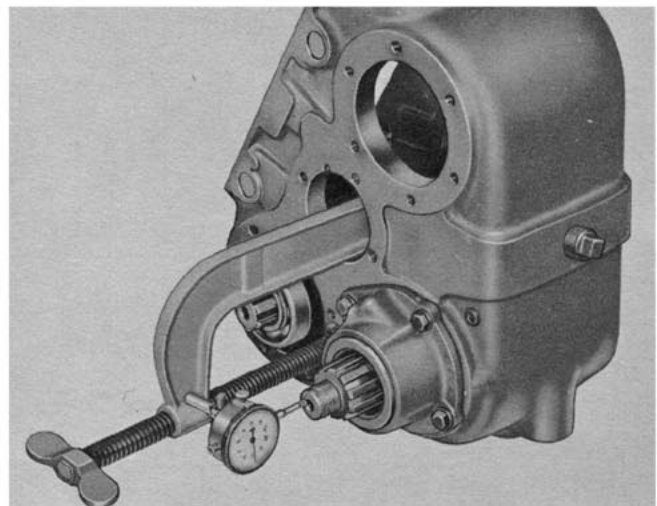

G. Rotate the shaft to seat the bearings. Mount a dial indicator against the rear end of the shaft to check the amount of endplay in the assembly.

Remove sufficient shims from under the front bearing cap to arrive at an adjustment of zero endplay and zero preload.

INSTALL FRONT OUTPUT GEAR

THE FRONT OUTPUT GEAR MUST BE INSTALLED IN THE CASE BEFORE THE IDLER ASSEMBLY IS INSTALLED:

A. Install the ball bearing on the hub of the gear.

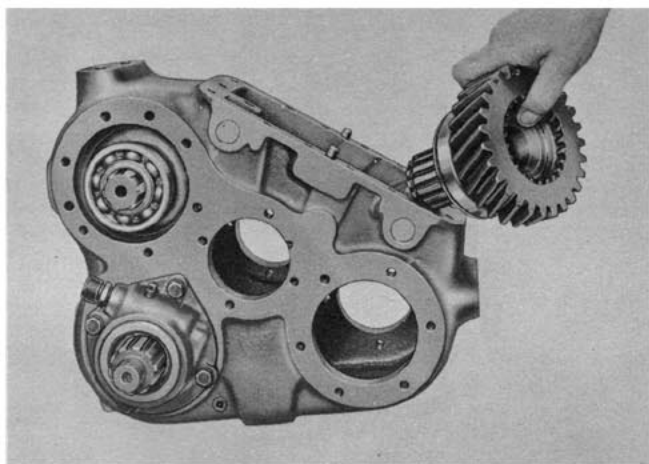

- B. Position the gear and bearing in the case and install the snap ring on the bearing.
- C. Install the rear bearing cap over a new gasket. Insert the cap screws and lock washers and tighten to specified torque.

INSTALL IDLER GEAR ASSEMBLY

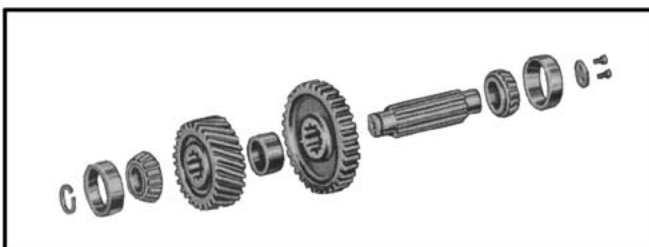

- A. Press rear bearing on idler shaft. Install snap ring.

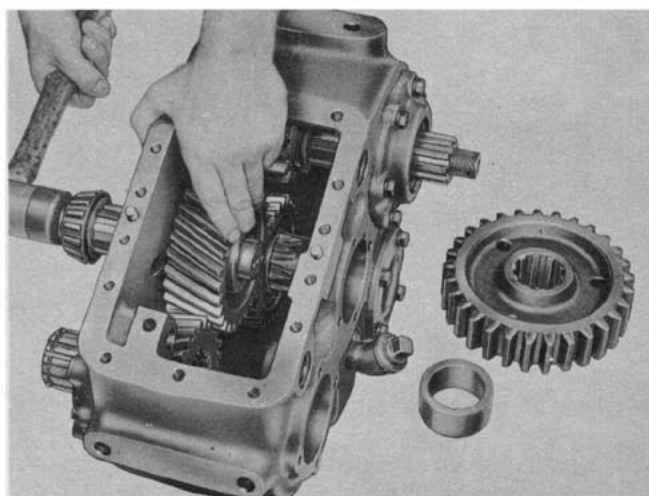

- B. Hold the Hi gear in position inside the case and tap the idler shaft through it with soft hammer. The short hub side of the gear goes to the outside (rear).

- C. Install the gear spacer on the shaft and then install the Lo gear with the long hub toward the outside (front) of the case.
- D. With the shaft in position, install the rear bearing cup in the case. Use a new gasket and install the rear bearing cap, lock washers and cap screws. Tighten cap screws to specified torque.

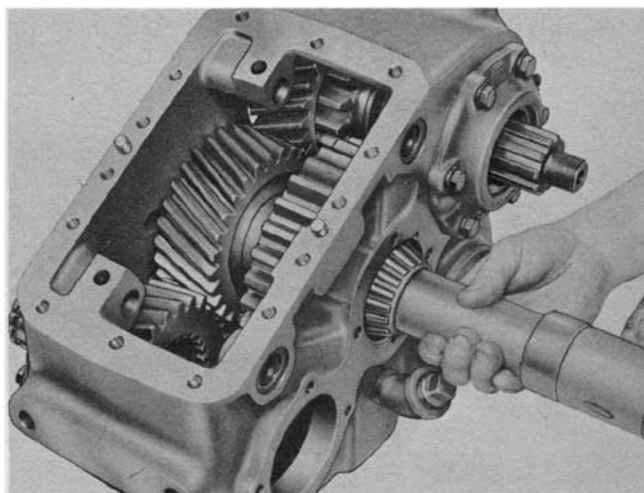

- E. Drive the front bearing onto the idler shaft. Hold the shaft rigid to avoid damaging the rear bearing and cup. Install the bearing retainer plate and cap screws. Lock wire.
- F. Tap the front bearing cup into place.
- G. Install sufficient shims to set up endplay in the idler assembly. Install the front bearing cap and secure with cap screws and lock washers.

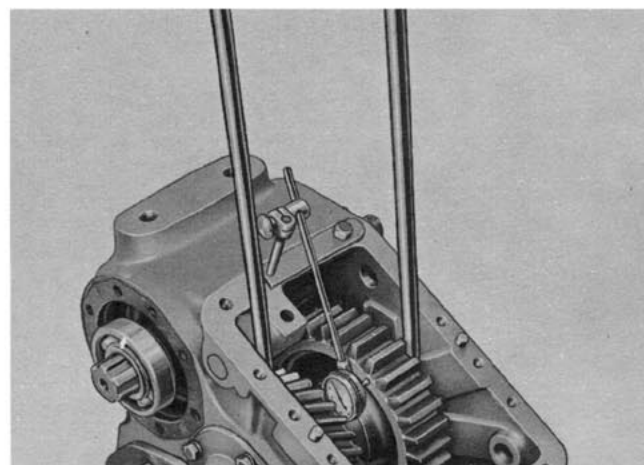

- H. Mount a dial indicator on the case with the stem set against the inside face of the Lo gear. Check the amount of endplay by working the assembly back and forth with two prybars as shown. Remove sufficient shims to arrive at a bearing adjustment of .003"-.005" endplay.

INSTALL FRONT OUTPUT SHAFT

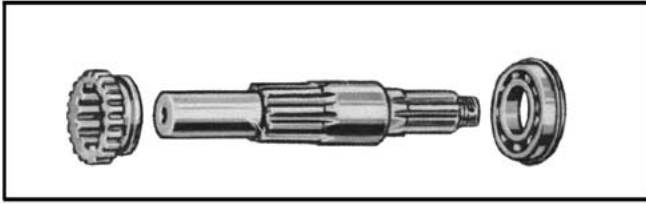

A. Install ball bearing on the shaft with bearing snap ring toward the outside.

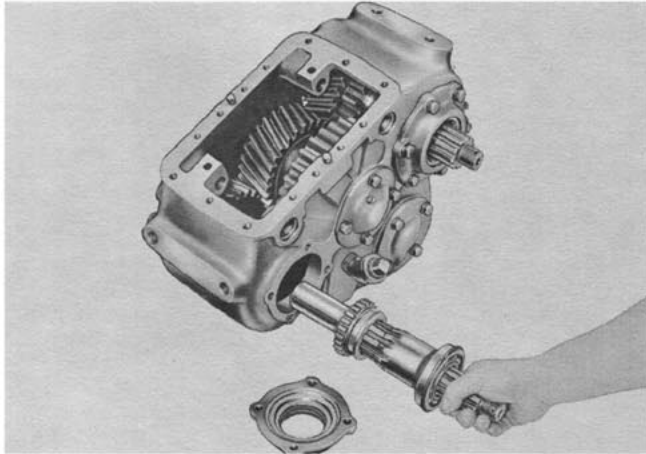

B. Install the sliding collar on the shaft. Slide the shaft into the case.

C. With the shaft in position, install a new gasket, bearing cap and oil seal, lock washers and cap screws. Tighten cap screws to specified torque.

INSTALL PARKING BRAKE ASSEMBLY

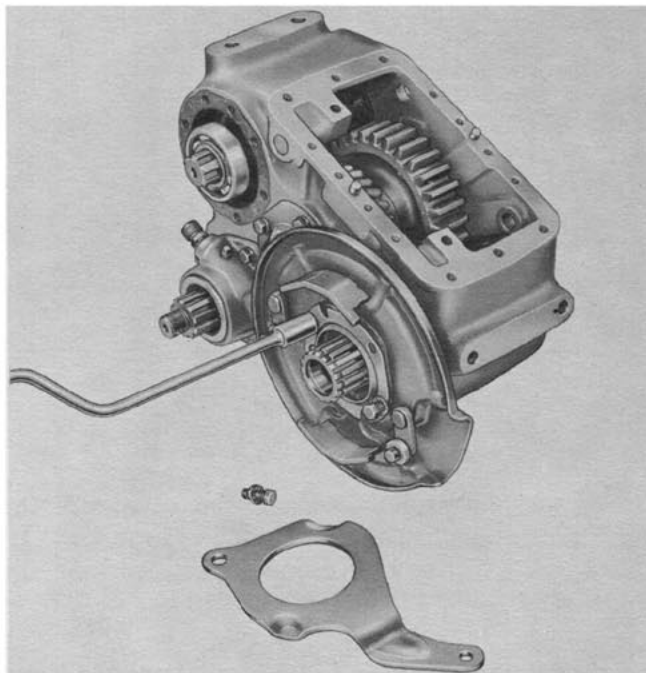

A. Position a new gasket and then mount the backing plate, deflector and stamped washer. Insert the cap screws and star washers and tighten to specified torque.

B. Position the brake lever on the backing plate.

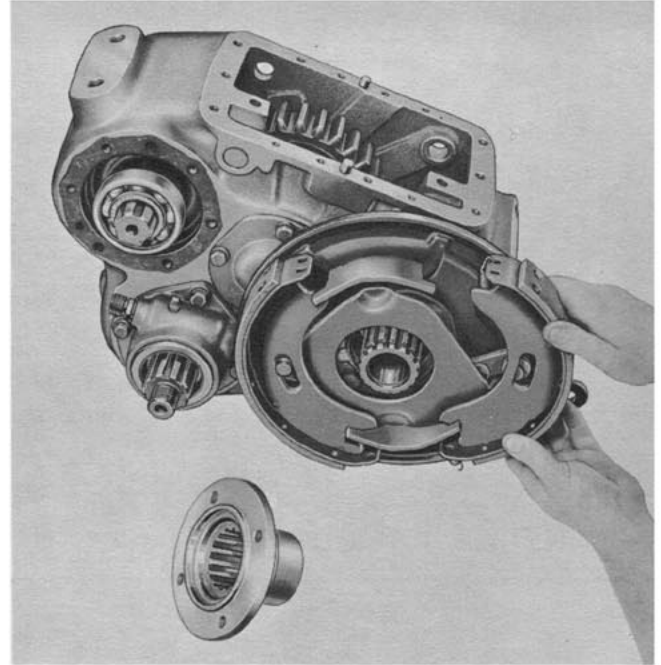

C. Position the brake shoes on the backing plate with actuating pawl in the web slot.

D. Hook-up brake shoe return springs.

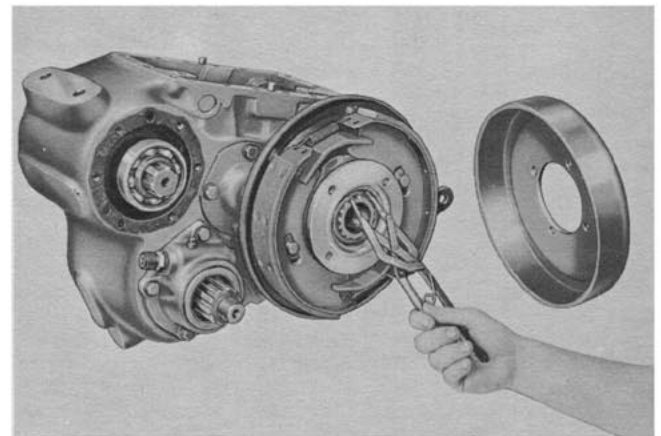

E. Slide the brake hub over the splines of the front output gear. Install the retaining ring.

F. Install the brake drum and lock washers and cap screws. Tighten cap screws to specified torque and insert lock wire.

G. Install the expansion plugs. The smaller goes in the bore of the front output gear and the larger in the brake hub.

INSTALL SHIFT SHAFTS

- A. Install new shift shaft oil seals in case (if old seals are not in good condition).

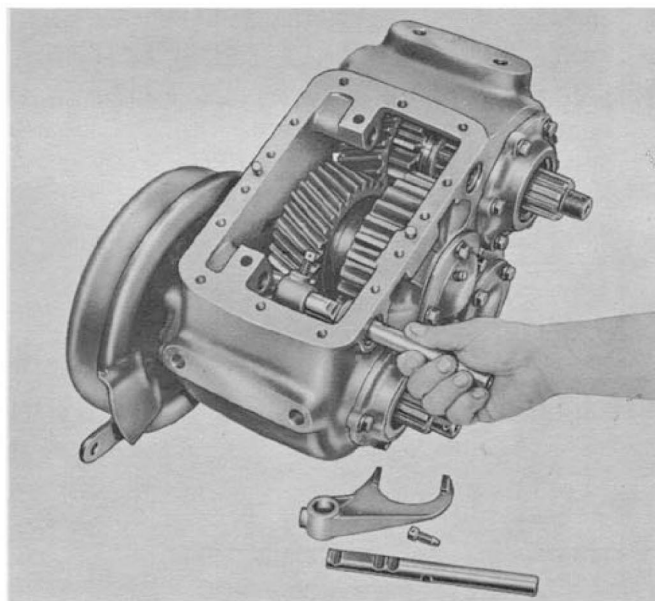

- B. Position the declutch fork in the collar.
 C. Grease the declutch shift shaft and slide it into the case and through the fork.
 D. With the shift shaft in position, insert the set screw. Tighten the screw and lock wire to the fork.
 E. Position the range shift fork in the sliding gear.
 F. Slide the range shift shaft through the fork. Install the set screw, tighten and lock wire to the shift fork.

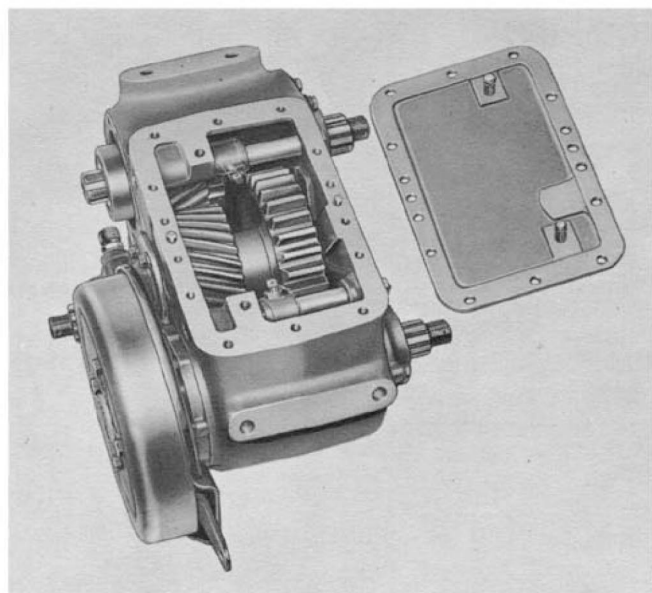

- G. Install the expansion plugs at the rear of the case and flatten to expand.
 H. Place the detent balls and springs in position in the case.
 I. Install the cover with a new gasket and tighten cap screws to specified torque.

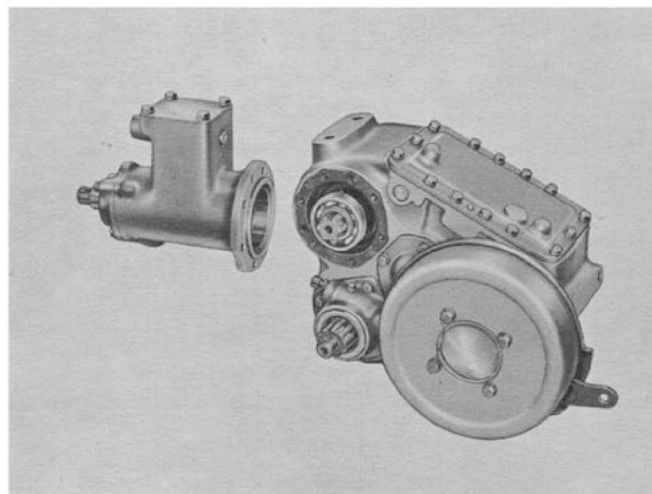

- J. Install the power take off assembly over a new gasket. Secure with cap screws and lock washers.
 K. Install the yokes or flanges and nuts and tighten to specified torque.

LUBRICATION

Install the drain plug and tighten. Turn the unit upright and pour one-half pint of recommended gear lubricant through the filler plug opening. Add some oil to the power take off. Do not fill the unit to the specified level until it is installed under the vehicle.

Transfer case lubricant specifications are listed in Meritor Field Maintenance Manual No. 1, "Lubrication."

TEST OPERATION OF THE UNIT

SHIFT TEST — with power take off and front axle declutch disengaged.

- A. HIGH RANGE. Move the range shift shaft to the rearmost position (so the sliding gear engages the direct drive gear); turning the input shaft should also turn the output to the rear axle.

- B. **LOW RANGE.** Move the range shift shaft to the forwardmost position (so the sliding gear disengages the direct drive gear); turning the input shaft should also turn the output to the rear axle.
- C. **NEUTRAL.** Move the range shift shaft to the intermediate position between Hi and Lo; turning the input shaft should *not* turn the output to the rear axle.

TEST POWER TAKE OFF UNIT

- A. **ENGAGED.** Move the shift shaft to the forwardmost position to engage the P.T.O.; turning the input shaft should also turn the P.T.O. shaft.

TEST FRONT AXLE DECLUTCH

- A. **ENGAGED.** Move the declutch shift shaft to rearmost position; turning the input shaft should also turn the output to the front axle.

TORQUE SPECIFICATIONS

CAP SCREWS

LOCATION ON UNIT	DIAM-ETER	NO. THREADS	TORQUE—LB. FT.	
			Min.	Max.
Top cover	3/8"	16	38	49
Bearing caps (all)	3/8"	16	38	49
Brake drum	7/16"	14	60	77
Brake mounting	7/16"	14	60	77
P.T.O. to case	3/8"	16	38	49
P.T.O. bearing cap to housing	3/8"	16	38	49
P.T.O. top cover	3/8"	16	38	49
YOKE OR FLANGE NUTS				
Input shaft	1"	20	300	400
Front output shaft	1"	20	300	400
Rear output shaft	1"	20	300	400
P.T.O. shaft	1"	20	300	400

Torques given apply to parts coated with machine oil; for dry (or "as received") parts, increase torques 10%; for parts coated with multi-purpose gear oil, decrease torques 10%. Nuts on studs use same torque as for driving the stud.



Meritor Heavy Vehicle Systems, LLC
2135 West Maple Road
Troy, MI 48084 USA
800-535-5560
meritor.com

Information contained in this publication was in effect at the time the publication was approved for printing and is subject to change without notice or liability. Meritor Commercial Vehicle Systems reserves the right to revise the information presented or discontinue the production of parts described at any time.

Copyright 1977
Meritor, Inc.
All Rights Reserved

Printed in the USA

Maintenance Manual 3A
Revised 07-77
16579/24240



Technical Bulletin

Replacing the Idler Shaft (3880-U-723)

T-223 Transfer Case

The idler shaft currently used in T-223 transfer cases has changed from the original design as described below.

The original idler shafts (**Figure 1**) have one or two tapped holes in the front bearing journal end to allow for mounting a bearing retainer plate. Some of these shafts also have a snap ring groove cut into the rear bearing journal outer diameter. A snap ring is used to retain the idler shaft rear bearing on these original shafts.

All current idler shafts (**Figure 2**) used in T-223 transfer cases do not have the tapped holes or the snap ring groove. The front and rear bearings are now retained on the idler shaft solely by the bearing caps. Bearing end play adjustment continues to be controlled by shims located between the case housing and idler shaft front bearing cap.

NOTE: When installing the new idler shaft assembly into the case housing, ensure that the front and rear bearing cones are correctly seated on the shaft against shoulders.

When replacing an original design idler shaft with a current design shaft use the following procedures and those indicated in Meritor Maintenance Manual 3A, *Transfer Cases*. Call Meritor's Customer Service Center at 800-535-5560 to order this publication.

- A. Disassemble the transfer case.
- B. Discard the idler shaft, front bearing retainer plate, one or two capscrews and the rear bearing retainer snap ring that were removed from the case housing.
- C. Reassemble the transfer case. Install the new idler shaft.

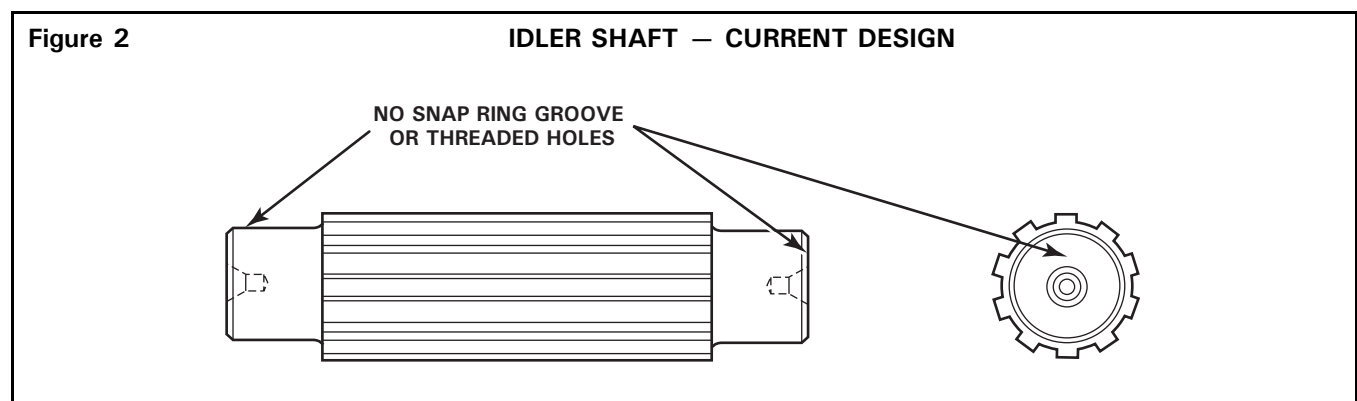
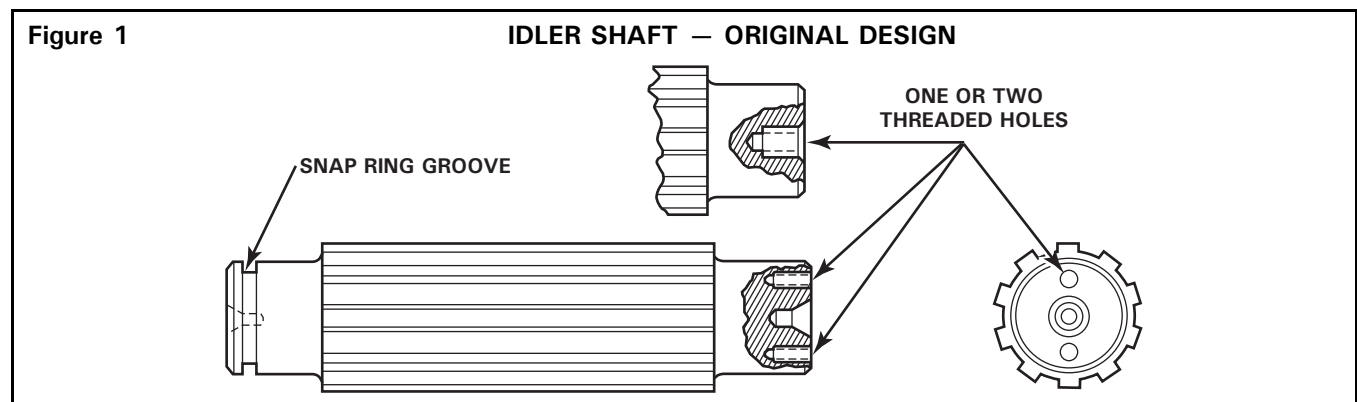



Meritor Heavy Vehicle Systems, LLC
2135 West Maple Road
Troy, MI 48084 USA
248-435-1085
800-535-5560 (North America only)
meritor.com

Information contained in this publication was in effect at the time the publication was approved for printing and is subject to change without notice or liability. Meritor Commercial Vehicle Systems reserves the right to revise the information presented or discontinue the production of parts described at any time.

Meritor do Brasil Ltda.
Av. João Batista, 824
06097-900 Osasco-SP
BRAZIL
(55-11) 7084-6510
Fax: (55-11) 7084-6600

Meritor Commercial Vehicle Systems Saint-Etienne S.A.
4, Rue Jean Servanton
Boite Postale 656
42042 Saint Etienne Cedex 1
FRANCE
(33) 477.92.88.00 Fax: (33) 477.92.88.93

TP-9529
Issued 12-94
(Supersedes TSA-4-43)
47865/Meritor