



Technical Bulletin

Installation and Adjustment Procedures for Meritor Automatic Slack Adjusters

Important Information

Meritor automatic slack adjusters (ASAs) should not need to be manually adjusted in service. ASAs should not have to be adjusted to correct excessive push rod stroke. The excessive stroke may be an indication that a problem exists with the foundation brake, ASA, brake actuator or other system components.

Meritor recommends troubleshooting the problem, replacing suspect components and then confirming proper brake operation prior to returning the vehicle into service.

In the event that a manual adjustment must be made (although not a common practice), a service appointment and full foundation brake, ASA, and other system component inspection should be conducted as soon as possible to ensure integrity of the overall brake system.

For Meritor brake adjustment, refer to the brake adjustment tables in this technical bulletin. For non-Meritor brake adjusters, refer to the brake manufacturer's service procedures.

Hazard Alert Messages

Read and observe all Warning and Caution hazard alert messages in this publication. They provide information that can help prevent serious personal injury, damage to components, or both.

ASBESTOS AND NON-ASBESTOS FIBERS WARNING

Some brake linings contain asbestos fibers, a cancer and lung disease hazard. Some brake linings contain non-asbestos fibers, whose long-term effects to health are unknown. You must use caution when you handle both asbestos and non-asbestos materials.

WARNING

To prevent serious eye injury, always wear safe eye protection when you perform vehicle maintenance and service.

Park the vehicle on a level surface. Block the wheels to prevent the vehicle from moving. Support the vehicle with safety stands. Do not work under a vehicle supported only by jacks. Jacks can slip or fall over. Serious personal injury and damage to components can result.

Before you service a spring chamber, carefully follow the manufacturer's instructions to compress and lock the spring to completely release the brake. Verify that no air pressure remains in the service chamber before you proceed. Sudden release of compressed air can cause serious personal injury and damage to components.

You must disengage a pull pawl before rotating the manual adjusting nut, or you will damage the pawl teeth. A damaged pawl will not allow the slack adjuster to automatically adjust brake clearance. Replace damaged pawls before putting the vehicle in service.

How to Obtain Additional Maintenance, Service and Product Information

Refer to Maintenance Manual 4, Cam Brakes and Automatic Slack Adjusters; and Parts Catalog PB-8857, Brake, Trailer Axle and Wheel Attaching Parts. To obtain these publications, visit Literature on Demand at meritor.com.

Automatic Slack Adjusters

Since January 1993, some parts of Meritor automatic slack adjusters are not serviceable or interchangeable with parts from earlier models.

Never mix automatic slack adjusters on the same axle. Always use replacement parts that were originally designed for the brake system to help ensure maximum brake performance.

How an Automatic Slack Adjuster Works

When you install an automatic slack adjuster, you set the brake chamber stroke measurement, which is the correct shoe-to-drum clearance. Figure 1. When linings wear, this clearance increases, and the air chamber push rod must travel farther to apply the brakes.

When this happens, the slack adjuster will automatically adjust during the return stroke to maintain the correct shoe-to-drum clearance. If the air brake chamber push rod stroke is within limits during operation, no adjustment occurs.

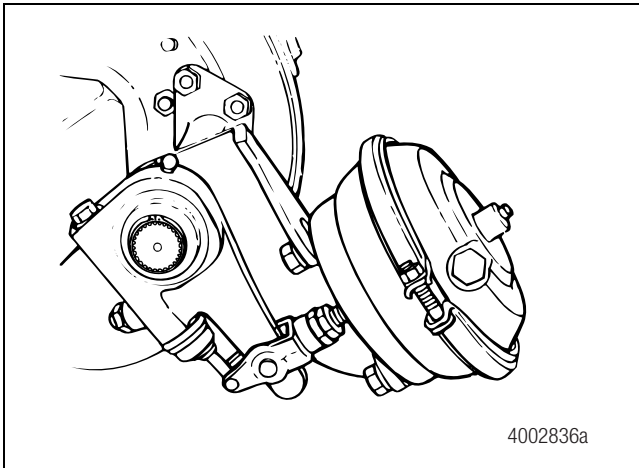

Figure 1

Handed and Unhanded Slack Adjusters

There are two automatic slack adjuster designs: handed and unhanded. Handing refers only to the location of the pawl, which is used for clearance issues on the vehicle. For most applications, install a handed automatic slack adjuster so that the pawl faces INBOARD on the vehicle.

The pawl can be on either side or on the front of the slack adjuster housing. Figure 2.

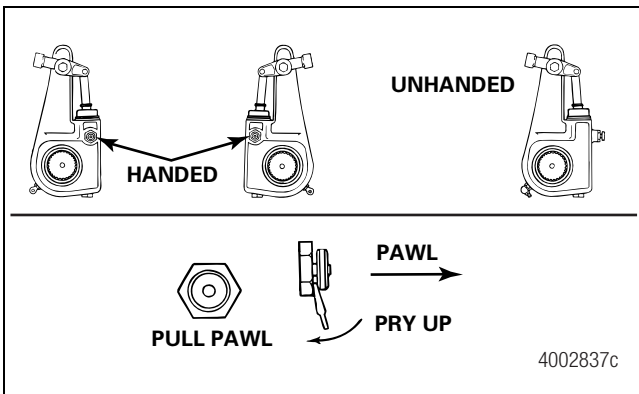

Figure 2

Pull Pawls

Pull pawls are spring loaded. Pry the pull pawl at least 1/32-inch to disengage the teeth. Figure 2. When you remove the pry bar, the pull pawl will re-engage automatically.

Clevis Types and Thread Sizes

A one-piece, threaded clevis is standard equipment on most Meritor automatic slack adjusters, including factory-installed slack adjusters on Q Plus™ LX500 and MX500 cam brakes, and all service replacement parts.

Meritor automatic slack adjusters and clevises are designed to be used as a system. Always use genuine Meritor replacement parts. Although parts from other manufacturers can look the same, differences can exist that will affect brake system performance.

The threaded-type clevis is available in two different pin spacings, 1.30-inches (33 mm) and 1.38-inches (35 mm). The initial slack adjuster set-up is unique for each pin spacing. Refer to Table E for correct installation. Figure 3.

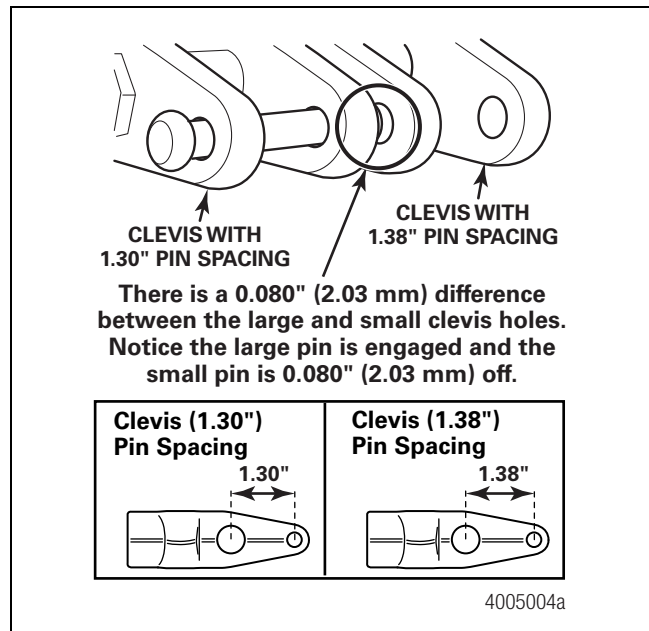

Figure 3

Threaded Clevis for Straight or Offset Applications

A threaded clevis can be either straight or offset. If service replacement is required, replace a straight clevis with a straight clevis and an offset clevis with an offset clevis to maintain the correct brake design and set up. Figure 4.

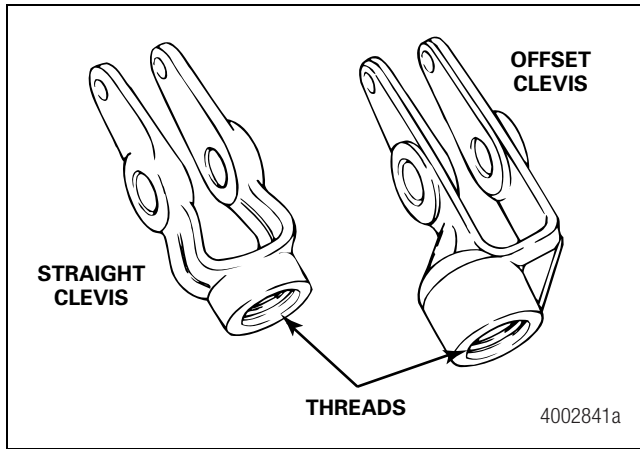

Figure 4

Thread Sizes

Straight and offset clevis designs are available in two common thread sizes to match push rod threads.

Table A: Thread Sizes

Chambers	Thread Sizes
9, 12, 16	1/2"-20 UNF
20, 24, 30, 36	5/8"-18 UNF

Meritor Automatic Slack Adjusters are Color-Coded to Brake Type and Air Chamber Size

Meritor uses either black, red, yellow, green or blue to color-code an automatic slack adjuster's internal actuator piston according to brake type and air chamber size.

Meritor uses a mylar tag on the body of the current-design slack adjuster to identify the color of the internal actuator piston.

Mylar Tag — Current Design

A mylar tag is attached to the current-design slack adjuster with a press-in boot. The color of the actuator piston is printed on the mylar tag. Figure 5.

Color-Coded Tie Wrap — Previous Design

On previous-design slack adjusters, a color-coded tie wrap attaches the boot to the slack adjuster body. The tie wrap color matches the color of the actuator piston. Figure 5.

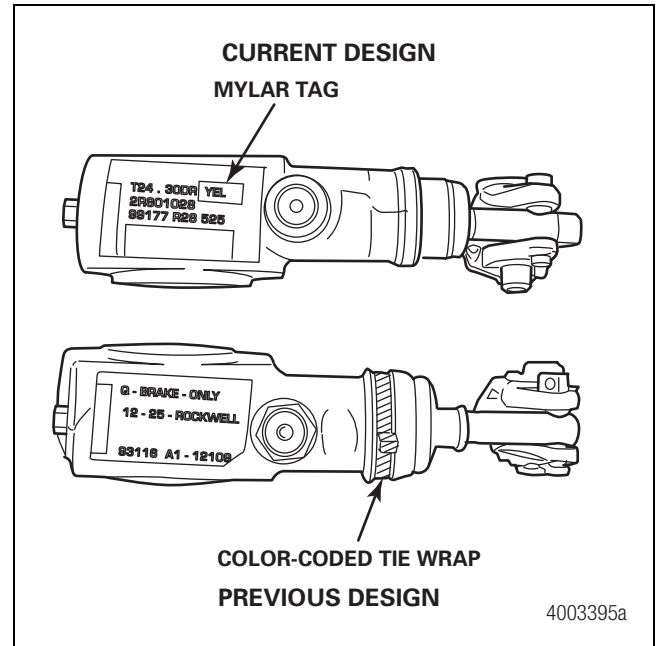

Figure 5

Important Note

While in service, it is possible that the boot's tie wrap might have been replaced with a tie wrap of a different color than originally installed at manufacture. If this happens, the tie wrap will not correctly identify the brake type and air chamber size.

Meritor recommends that you remove the boot from the slack adjuster to determine the color of the actuator piston, which identifies the brake type and air chamber size.

For a complete color-coding list, refer to Parts Catalog PB-8857, Brake, Trailer Axle and Wheel Attaching Parts.

When You Replace an Automatic Slack Adjuster

The original equipment manufacturer paints the chassis and slack adjusters, which includes the mylar tag or tie wrap, depending on the slack adjuster model.

When you replace an automatic slack adjuster, the color of the actuator piston on the new slack adjuster must match the color of the actuator piston on the in-service slack adjuster you'll replace.

Check the mylar tag or color-coded tie wrap, or remove the boot as described below, to identify the color of the actuator piston. To ensure a correct installation, this color must match the color of the actuator piston on the in-service slack adjuster you'll replace.

- **If you are unsure of the color of the actuator piston on the in-service slack adjuster:** Remove the piston boot to see the color of the actuator piston to ensure a correct installation. The color must be the same as the new slack adjuster you'll install.

Installation

NOTE: If the slack adjuster is not a Meritor automatic slack adjuster, refer to the manufacturer's literature for the correct service procedures.

While in service, it is possible that the boot's tie wrap might have been replaced with a tie wrap of a different color than originally installed at manufacture. If this happens, the tie wrap will not correctly identify the brake type and air chamber size.

Meritor recommends that you remove the boot from the slack adjuster to determine the color of the actuator piston, which identifies the brake type and air chamber size.

When You Replace an Automatic Slack Adjuster

The original equipment manufacturer paints the chassis and slack adjusters, which includes the mylar tag or tie wrap, depending on the slack adjuster model.

When you replace an automatic slack adjuster, the color of the actuator piston on the new slack adjuster must match the color of the actuator piston on the in-service slack adjuster you'll replace.

Check the mylar tag or color-coded tie wrap, or remove the boot as described below to identify the color of the actuator piston. To ensure a correct installation, this color must match the color of the actuator piston on the in-service slack adjuster you'll replace.

- **If you are unsure of the color of the actuator piston on the in-service slack adjuster:** Remove the piston boot to see the color of the actuator piston to ensure a correct installation. The color must be the same as the new slack adjuster you'll install.

For a complete color-coding list, refer to Parts Catalog PB-8857, Brake, Trailer Axle and Wheel Attaching Parts.

1. Check the camshaft and bushings and seals for wear and corrosion. Turn the camshaft by hand to check for smooth operation. Repair or replace parts as required.
2. Apply the service brake and spring brake several times. Check that the chamber return spring retracts the push rod quickly and completely. If necessary, replace the return spring or the air chamber.
3. Verify that the new automatic slack adjuster is the same length as the one you are replacing. Refer to Table B.

Table B: Chamber and Automatic Slack Adjuster Sizes

Length of Slack Adjuster (Inches)	Size of Chamber (Square Inches)
5	9, 12, 16, 20, 24, 30*
5-1/2	9, 12, 16, 20, 24, 30, 36*
6	24, 30, 36
6-1/2	30, 36

*Use an auxiliary spring on slack adjusters used with size 9 and 12 chambers. A size 9 or 12 chamber return spring cannot supply enough spring tension to completely retract the slack adjuster.

4. If the vehicle has spring brakes, follow the chamber manufacturer's instructions to compress and lock the springs to completely release the brakes. Verify that no air pressure remains in the service chambers.

CAUTION

Most Meritor automatic slack adjusters manufactured after January 1990 have lubrication holes in the gear splines. Do not operate the actuator rod before you install the slack adjuster. Lubricant can pump through the holes and onto the splines. Damage to components can result.

5. If the automatic slack adjuster gear has a 10-tooth spline, apply Meritor specification O-637, part number 2297-U-4571, anti-seize compound, or equivalent. This anti-seize compound is a corrosion-control grease. Do not mix this grease with other greases.

NOTE: Install the slack adjuster so that you can remove a conventional pawl or disengage a pull pawl when you adjust the brake.

6. Add the thick camshaft thrust washer. Install the slack adjuster onto the camshaft. Position the slack adjuster so that you can access the pawl when you adjust the brake.
7. Add thin camshaft spacing washers, followed by a thick camshaft spacing washer (thick spacing washer must be next to the snap ring). Install the snap ring.
8. Verify that camshaft axial end play on trucks and tractors is 0.005-0.060-inch (0.127-1.52 mm). On trailers, no end play adjustment is required. End play is controlled by the snap ring near the cam head end of the camshaft.

- **If axial end play is not 0.005-0.060-inch (0.127-1.52 mm):** Remove the snap ring. Add or remove the appropriate number of spacing washers to achieve the correct specification.

9. If the assembly has a "bolt-on" type camshaft, refer to Assembly of the Slack Adjuster for a Bolted Camshaft.
10. Install the clevis onto the push rod.
11. Disengage the pull pawl. Turn the manual adjusting nut to align the holes in the slack adjuster arm and clevis. Figure 6.

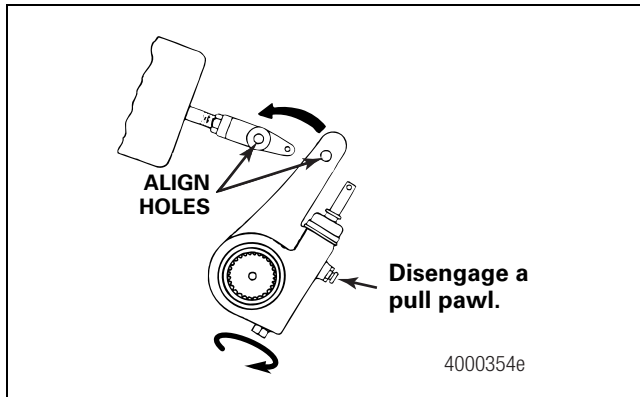

Figure 6

Assembly of the Slack Adjuster for a Bolted Camshaft

Refer to Figure 7 for measurement location and component description.

Place bracket washer (1229H4090) between slack and bracket. Place the slack on the camshaft and check in this order.

1. Alignment of slack arm to chamber centerline, maximum 0.100" mismatch.
2. Slack body to wing bracket clearance during slack actuation.
 - **If slack interferes with bracket:** Shim between slack and bracket washer with the following washers and repeat Step 1.

Part Number	Nominal Thickness
1229-H-4090	0.104"
1229-W-2935	0.030"
1229-X-2936	0.054"

3. Use hardened camshaft step washer and spacer washers to set up end play and slack between 0.005" and 0.060". Add spacer washers between the slack body and the hardened camshaft step washer.

Hardened Camshaft Step Washer Part Number	Nominal Step Thickness
1229-L-5030	0.260"
1229-M-5031	0.405"

Spacer Washer Part Number	Nominal Thickness
1229-W-1505	0.090"
1229-D-5022	0.054"

Table C: Typical End Play Washer Requirements

Measured Distance from End of Camshaft to Edge of Slack	Hardened Camshaft Step Washer Thickness	Spacer Washer Thickness
0.200" to 0.255"	0.260"	None
0.256" to 0.309"	0.260"	0.054"
0.310" to 0.345"	0.260"	0.090"
0.346" to 0.400"	0.405"	None
0.401" to 0.454"	0.405"	0.054"
0.455" to 0.490"	0.405"	0.090"
0.491" to 0.539"	0.405"	0.054" and 0.090"

4. Install the lock washer (WA-18) and bolt (S-2812-2, 0.50"-13 thread x 1.50" long), then tighten bolt to 85-115 lb-ft (115-155 N•m).
5. Verify end play is between 0.005-inch and 0.060-inch.
6. Actuate the brake by pulling on the slack adjuster to ensure the cam and roller move freely and that the shoes retract when the slack adjuster is released.

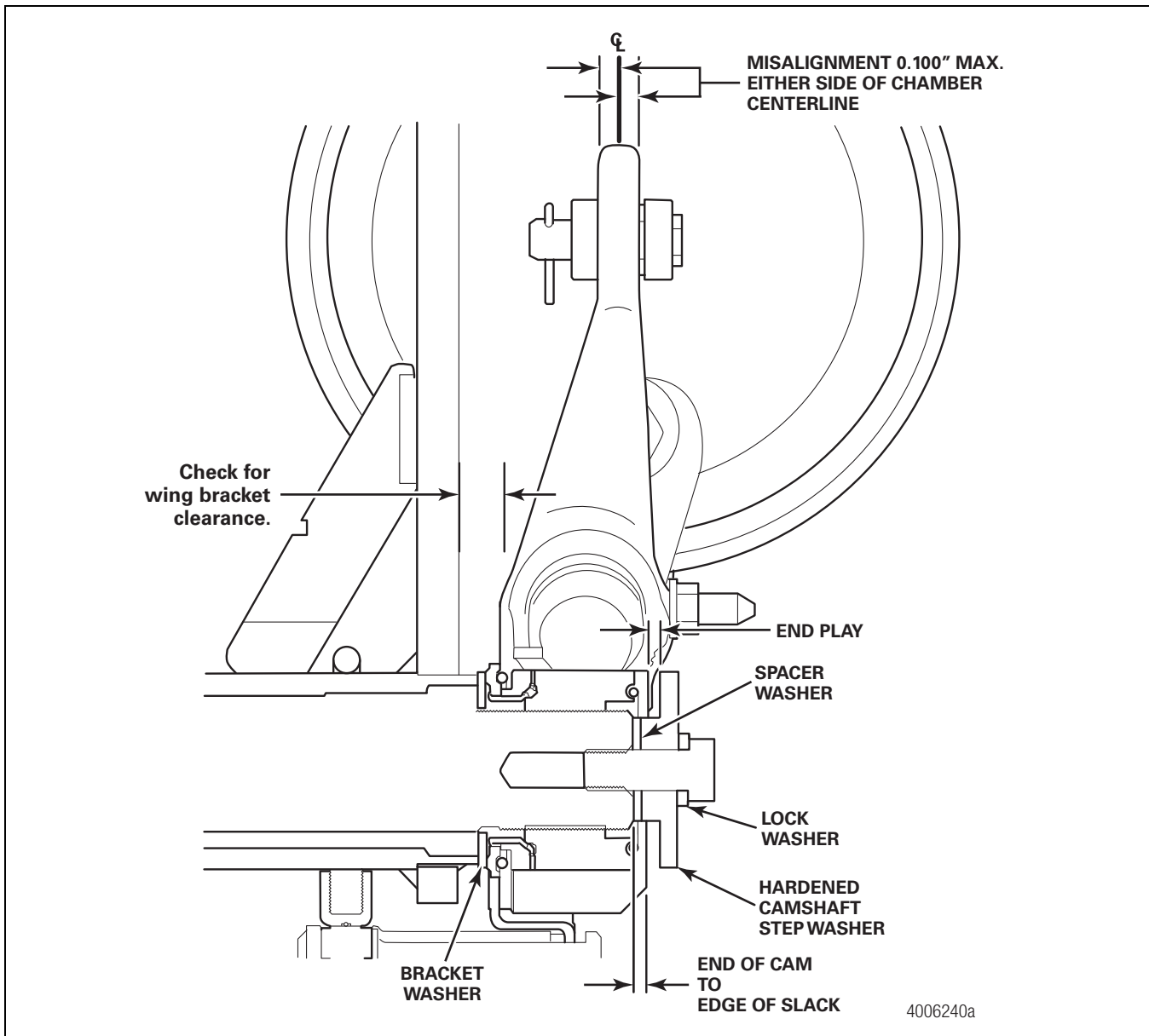

Figure 7

Welded Clevis

1. Check the clevis position using the brake slack adjuster position (BSAP) method. Refer to Table E. Apply Meritor specification O-637, part number 2297-U-4571, anti-seize compound or equivalent to the large and small clevis pins. This anti-seize compound is a corrosion-control grease. Do not mix this grease with other greases.

CAUTION

Always replace used clevis pin retainer clips with new ones when you service an automatic slack adjuster or chamber. Do not reuse retainer clips. Discard used clips. When you remove a retainer clip, it can bend or "gap apart" and lose retention. Damage to components can result.

2. Install new clevis pin retainer clips or cotter pins to secure the clevis pins. Retainer clips must be fully installed and positioned around the side of the clevis pin. Figure 8.

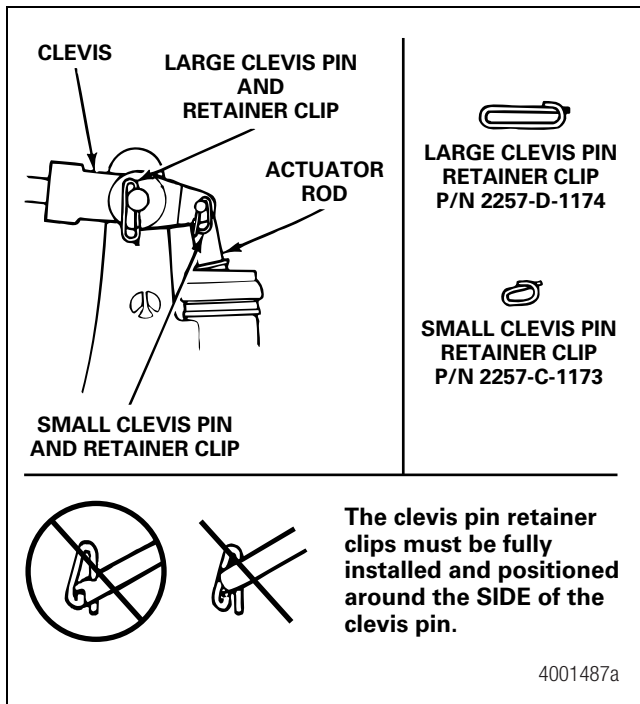

Figure 8

Threaded Clevis

The threaded-type clevis is available in two different pin spacings, 1.30-inches (33 mm) and 1.38-inches (35 mm). Based on your pin spacing, install the threaded clevis to the correct position using the template or brake slack adjuster position (BSAP) method. Refer to Table E. Figure 9.

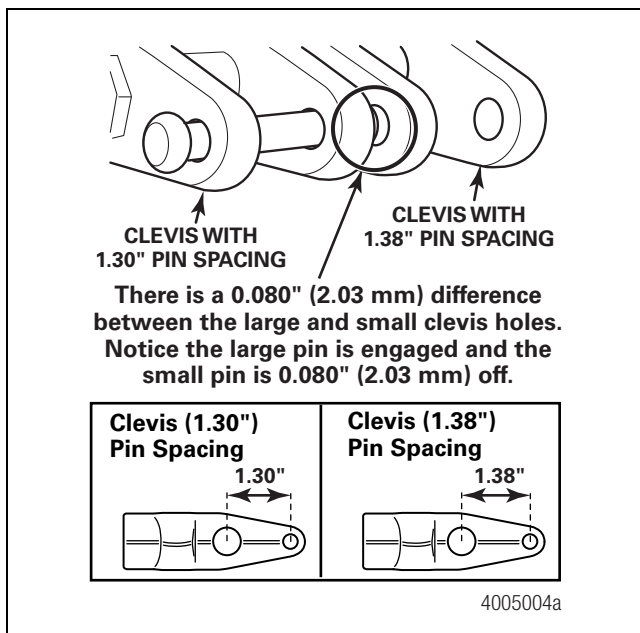

Figure 9

Verify That the Slack Adjuster Angle is Correct

There are two methods for determining the correct geometry for the slack adjuster.

- A. Brake Slack Adjuster Position (BSAP)
- B. Template

Trucks and Tractors Equipped with Long-Stroke Chambers

Because of concerns regarding slack adjuster-to-axle clearances at the end of longer strokes, Meritor has revised instructions to use the BSAP method *only*. Trailers are not affected by this change. Refer to Brake Slack Adjuster Position (BSAP) Method and Table E in this section.

Trucks and Tractors Equipped with Standard-Stroke Chambers; Trailers Equipped with Standard- or Long-Stroke Chambers

You can use either the Brake Slack Adjuster Position (BSAP) method or the template method to verify that slack adjuster angles are correct on trucks and tractors with standard-stroke brake chambers and trailers with standard- and long-stroke brake chambers. Refer to Table E.

Template Method

⚠ CAUTION

There are four different installation templates for Meritor automatic slack adjusters. The templates are not interchangeable. You must use the correct template and clevis pin spacing and you must adjust the clevis position as described below. If you use the wrong combination and install the clevis in the wrong position, the slack adjuster will not adjust the brake correctly. If the slack adjuster underadjusts, then stopping distances are increased. If the slack adjuster overadjusts, then the linings may drag and damage the brake.

1. Use the correct Meritor automatic slack adjuster template to measure the length of the slack adjuster. The marks by the holes in the small end of the template indicate the length of the slack adjuster. Refer to Table E.
2. Install the large clevis pin through the large holes in the template and the clevis.
3. Select the hole in the template that matches the length of the slack adjuster. Hold that hole on the center of the camshaft.
4. Look through the slot in the template to see if the small clevis hole completely aligns within the slot.

- **If the small clevis hole doesn't align within the slot:**
Adjust the clevis until you can see the small clevis pin hole within the slot. Figure 10.

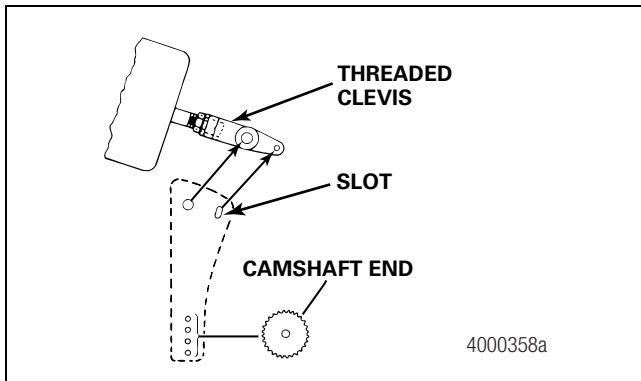

Figure 10

5. Verify that the thread engagement between the clevis and push rod is 0.5-0.625-inch (12.7-15.9 mm). Figure 11.

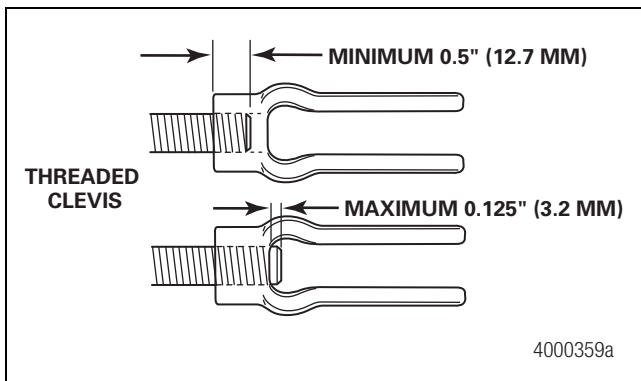

Figure 11

6. Verify that the push rod does not extend through the clevis more than 0.125-inch (3.2 mm).
 - **If the push rod extends through the clevis more than 0.125-inch (3.2 mm):** Cut the push rod or install a new air chamber and push rod.
7. Tighten the jam nut against the clevis to the torque specification in Table D. 

Table D: Jam Nut Torque Specifications

Threads	Torque
1/2-20	20-30 lb-ft (27-41 N•m)
5/8-18	35-50 lb-ft (48-68 N•m)

8. Use the following steps to install the automatic slack adjuster.
 - A. Determine the clevis pin spacing.
 - B. Determine the brake offset.
 - C. Refer to Table E for the recommended installation.

Table E: Meritor Automatic Slack Adjuster Installation Instructions

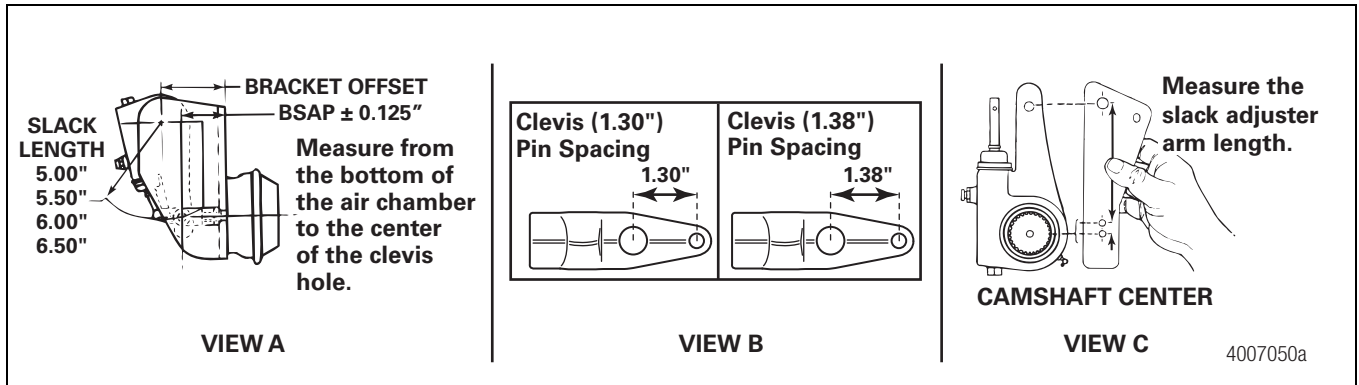

1.30" Clevis Pin Spacing

Slack Length	Bracket Offset Refer to View A.	Clevis Pin Spacing Refer to View B.	± 0.125" BSAP Installation	Clevis Type	Chamber Type	Optional Template Method Refer to View C.		Vehicle Application
						Template Color	Template Part Number	
5.00" 5.50" 6.00" 6.50"	3.75" and 3.81"	1.30"	2.25"	Threaded or Welded	Standard Stroke or Long Stroke	Grey	TP-10130	Truck or Tractor Drum Brake

1.38" Clevis Pin Spacing

Slack Length	Bracket Offset Refer to View A.	Clevis Pin Spacing Refer to View B.	± 0.125" BSAP Installation	Clevis Type	Chamber Type	Optional Template Method Refer to View C.		Vehicle Application
						Template Color	Template Part Number	
5.00" 5.50" 6.00"	3.75" and 3.81"	1.38"	2.75"	Threaded	Standard Stroke or Long Stroke	Dark Brown	TP-4786	Truck or Tractor Drum Brake/Straight or Offset Clevis
			White			TP-4781	Coach Drum Brake	
6.50"			2.62"			Dark Brown	TP-4786	Truck or Tractor Drum Brake/Straight or Offset Clevis
						White	TP-4781	Coach Drum Brake

1.38" Clevis Pin Spacing Must Be Used with Other Bracket Offsets

Slack Length	Bracket Offset	Clevis Pin Spacing	± 0.125" BSAP Installation	Clevis Type	Chamber Type	Optional Template Method Refer to View C.		Vehicle Application
						Template Color	Template Part Number	
5.00"	Other	1.38"	Not Applicable. Use Template Method.	Threaded	Standard Stroke or Long Stroke	Dark Brown	TP-4786	Truck or Tractor Drum Brake/Straight or Offset Clevis
5.50"						Tan		
6.00"						White	TP-4781	Coach Drum Brake
6.50"								

If your combination is not shown, please contact the Meritor OnTrac™ Customer Call Center at 866-668-7221.

Brake Slack Adjuster Position (BSAP) Method

Use this method to ensure the correct position of welded or threaded clevises on standard- or long-stroke brake chambers.

When you install the slack adjuster, verify that the BSAP chamber dimension matches the dimension shown in Table E.

Adjustment

Measure Free Stroke

When you perform preventive maintenance procedures on an in-service brake, check both the free stroke and adjusted chamber stroke. Refer to the procedures in this section.

Free stroke sets the clearance between the linings and drum. The in-service free stroke may be slightly longer than 0.5-0.625-inch (12.7-15.9 mm) specified in this procedure. This is acceptable if the adjusted chamber stroke is within the limits shown in Table F and Table G.

1. Disengage a pull pawl. Use a screwdriver or equivalent tool to pry the pull pawl at least 1/32-inch (0.8 mm) to disengage the teeth.
2. Use a wrench to turn the adjusting nut COUNTERCLOCKWISE until the brake shoes contact the drum. Figure 12. Then back off the adjusting nut in the opposite direction 1/2 turn for drum brakes or 3/4 turn for disc brakes.

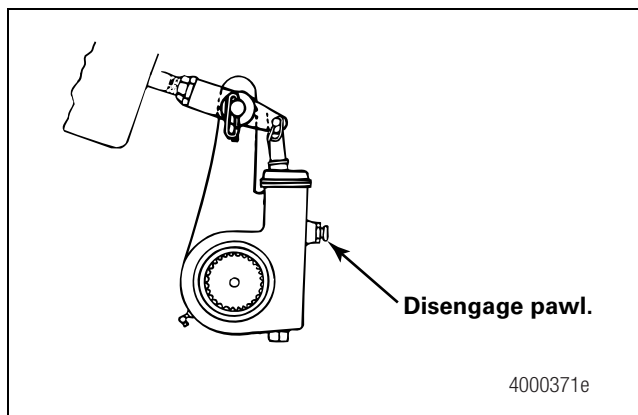

Figure 12

3. Measure the distance from the center of the large clevis pin to the bottom of the air chamber while the brake is released. The measurement you obtain is X in Figure 13.

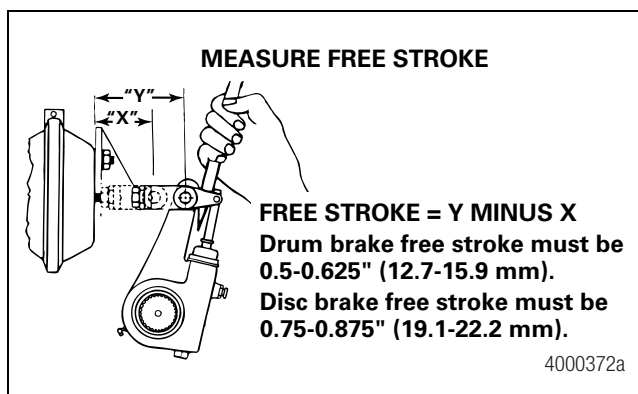

Figure 13

4. Use a pry bar to move the slack adjuster and position the linings against the drum, brakes applied. Measure the same distance again while the brakes are applied. The measurement you obtain is Y in Figure 13.

⚠ CAUTION

Do not set free stroke shorter than 0.5-0.625-inch (12.7-15.9 mm) for drum brakes. If the measurement is too short, linings can drag. Damage to components can result.

5. Subtract X from Y to obtain the in-service free stroke. The measurement must be 0.5-0.625-inch (12.7-15.9 mm) for drum brakes. Figure 13.
 - **If the free stroke measurement is not within specification:** Turn the adjusting nut 1/8 turn in the direction shown in Figure 14 and check the free stroke again. Continue to measure and adjust the stroke until the measurement is within specification.

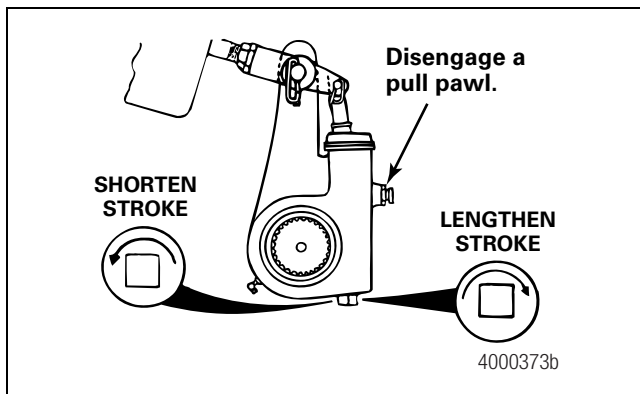

Figure 14

6. Re-engage the pull pawl by removing the screwdriver or equivalent tool. The pull pawl will re-engage automatically.
7. If the brakes have spring chambers, carefully release the springs. Test the vehicle before you return it to service.

Commercial Vehicle Safety Alliance (CVSA) Guidelines

Measure Push Rod Travel or Adjusted Chamber Stroke

Use the following procedure to check in-service push rod travel or adjusted chamber stroke on truck and tractor brakes.

1. The engine must be OFF. If the brake has a spring chamber, follow the manufacturer's instructions to release the spring. Verify that no air pressure remains in the service section of the chamber.
2. Verify that pressure is 100 psi (689 kPa) in the air tanks. Determine the size and type of brake chambers on the vehicle.

3. With the brakes released, mark the push rod where it exits the chamber. Measure and record the distance. Have another person apply and hold the brakes on full application. Figure 15. Hold the ruler parallel to the push rod and measure as carefully as possible. A measurement error can affect CVSA re-adjustment limits. CVSA states that "any brake 1/4-inch or more past the re-adjustment limit, or any two brakes less than 1/4-inch beyond the re-adjustment limit, will be cause for rejection."

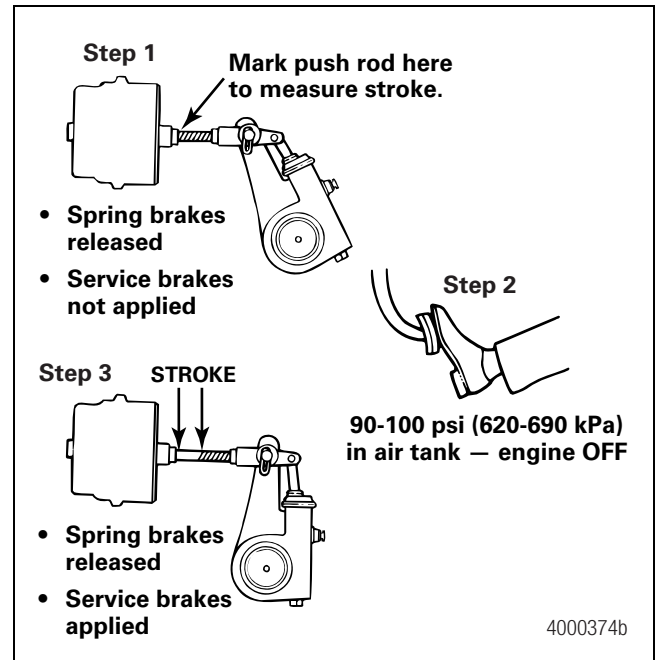

Figure 15

4. Measure the push rod travel or adjusted chamber stroke from where the push rod exits the brake chamber to your mark on the push rod. Measure and record the distance. Figure 15.
5. Subtract the measurement you recorded in Step 3 from the measurement you recorded in Step 4. The difference is the push rod travel or adjusted chamber stroke.
6. Refer to Table F or Table G to verify that the stroke length is correct for the size and type of air chambers on the vehicle.
 - **If the adjusted chamber stroke is greater than the maximum stroke shown in Table F or Table G:** Diagnose and correct the problem.

Table F: Standard-Stroke Clamp-Type Brake Chamber Data

Type	Outside Diameter (inches)	Brake Adjustment Limit (inches)
6	4-1/2	1-1/4
9	5-1/4	1-3/8
12	5-4/16	1-3/8
16	6-3/8	1-3/4
20	6-25/32	1-3/4
24	7-7/32	1-3/4
30	8-3/32	2
36	9	2-1/4

Table G: Long-Stroke Clamp-Type Brake Chamber Data

Type	Outside Diameter (inches)	Brake Adjustment Limit (inches)
16	6-3/8	2.0
20	6-25/32	2.0
24	7-7/32	2.0
24*	7-7/32	2.5
30	8-3/32	2.5

* For 3" maximum stroke type 24 chambers.

Alternate Method to Measure Push Rod Travel or Adjusted Chamber Stroke

Use the CVSA procedure, except in Steps 3 and 4, measure the distance from the bottom of the air chamber to the center of the large clevis pin on each of the brakes.

CVSA North American Out-of-Service Criteria Reference Tables

Information contained in Table F and Table G is for reference only. Consult the CVSA Out-of-Service Criteria Handbook for North American Standards, Appendix A. Visit their website at <http://64.35.82.7/> to obtain the handbook.



Meritor Heavy Vehicle Systems, LLC
 2135 West Maple Road
 Troy, MI 48084 USA
 866-OnTrac1 (668-7221)
 meritor.com

Information contained in this publication was in effect at the time the publication was approved for printing and is subject to change without notice or liability. Meritor Heavy Vehicle Systems, LLC, reserves the right to revise the information presented or to discontinue the production of parts described at any time.

Copyright 2013
 Meritor, Inc.
 All Rights Reserved

Printed in USA

TP-9173
 Revised 10-13
 (16579)