

MERITOR WABCO

Installation Guide

Enhanced Easy-Stop™ Trailer ABS 2S/2M, 4S/2M and 4S/3M Premium with PLC Installation Instructions

Hazard Alert Messages

Read and observe all Warning and Caution hazard alert messages in this publication. They provide information that can help prevent serious personal injury, damage to components, or both.

How to Obtain Additional Maintenance and Service Information

Refer to Maintenance Manual MM-0180, Enhanced Easy-Stop™ Trailer ABS with PLC, and Maintenance Manual 33, Easy-Stop™ Trailer ABS. To obtain these publications, call ArvinMeritor's Customer Service Center at 800-535-5560, or visit the Tech Library on our website at meritorwabco.com.

Differences Between Easy-Stop™ and Enhanced Easy-Stop™

There are some changes to Enhanced Easy-Stop™ that you need to be aware of before you begin the installation.

- Enhanced Easy-Stop™ includes Power Line Communication (PLC) function.
- The ECU/dual modulator valve assembly must be mounted as one unit.
- The LED on top of the ECU has been eliminated.
- The blink code tool LED does not operate simultaneously with the ABS lamp on the trailer.
- **For Enhanced Easy-Stop™ 4S/3M lift axle installations**, you must use TOOLBOX™ Software, version 4.6 or higher, to enable the lift axle function. It is not automatically enabled. Refer to Enabling the Lift Axle Function (4S/3M Installations) in the Appendix for instructions. For 4S/2M lift axle installations, the lift axle function is automatically enabled.

The valve portion of the ECU/dual modulator valve assembly contains two separate modulator valves that share common control and exhaust ports.

Each valve has three delivery ports. Therefore, the mounting orientation — whether the valve is facing the front or the rear of the trailer — determines sensor hookup.

If this assembly is mounted facing forward — toward the front of the trailer — the YE sensor connections go to the curbside and the BU sensor connections go to the roadside. If this assembly is mounted facing the rear, the YE sensor connections go to the roadside, and the BU sensor connections go to the curbside. Figure 1.

All premium systems use the same ECU/dual modulator valve assembly.

The ECU/dual modulator assembly cannot be used as a 2S/1M system.

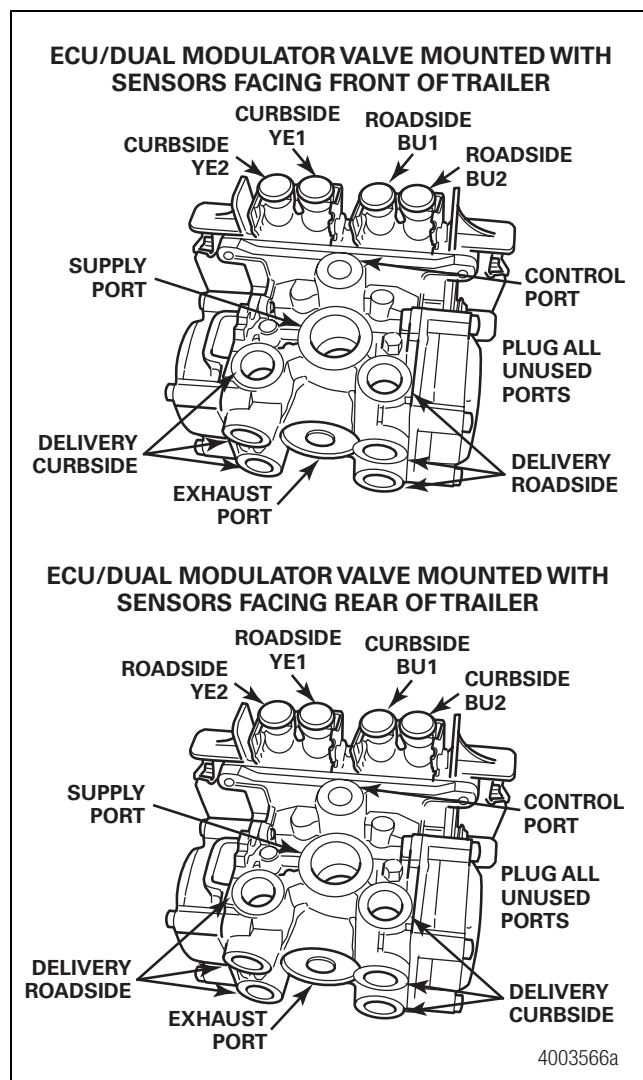

Figure 1

Preparation

⚠ WARNING

To prevent serious eye injury, always wear safe eye protection when you perform vehicle maintenance or service.

The Anti-lock Braking System (ABS) is an electrical system. When you work on the ABS, take the same precautions that you must take with any electrical system to avoid serious personal injury. As with any electrical system, the danger of electrical shock or sparks exists that can ignite flammable substances. You must always disconnect the battery ground cable before working on the electrical system.

Park the vehicle on a level surface. Block the wheels to prevent the vehicle from moving. Support the vehicle with safety stands. Do not work under a vehicle supported only by jacks. Jacks can slip and fall over. Serious personal injury and damage to components can result.

1. Before beginning the installation procedure, inspect the ECU/dual modulator valve assembly for damage that may have occurred during shipping or storage.
 - Look for crushed or bent connectors.
 - Verify that the retainer clips have not been bent or otherwise damaged.
 - Do not install a damaged ECU/dual modulator valve assembly. Notify your supervisor, or contact Meritor WABCO if there is any apparent damage.

2. Have the following installation material available.

- * ECU/dual modulator valve assembly
- * ABS relay valve and relay valve extension cable with bayonet connector (3M systems)
- * Power cable or power/diagnostic cable
- * Sensor extension cables (two pieces for 2S systems, four pieces for 4S systems)
- * Sensors (two or four) for non-ABS prepped axles
- * ABS Indicator Label (TP-95172)

5/8-inch O.D. nylon tubing for supply (frame mount)

Pipe plug (3/4-inch NPTF)

Schedule 80 hex pipe nipple (3/4-inch NPTF) for air tank mounts or two Grade 8 bolts (3/8-inch) and prevailing torque nuts for frame mounts

SAE-standard, DOT-approved thread sealant

To ensure correct lamp operation, use an incandescent-type DOT-approved lamp, or an LED with integral load resistor.

* Meritor WABCO components

End of line testing must be done after all installations. Meritor WABCO recommends using TOOLBOX™ Software to perform this testing. If you do not have TOOLBOX™ Software, this bulletin also includes instructions for testing without the software.

Installation

I. Install the ECU/dual modulator valve assembly.

The assembly may be mounted on the air tank or on the cross member of the vehicle.

Tank-Mounted

Refer to Figure 2.

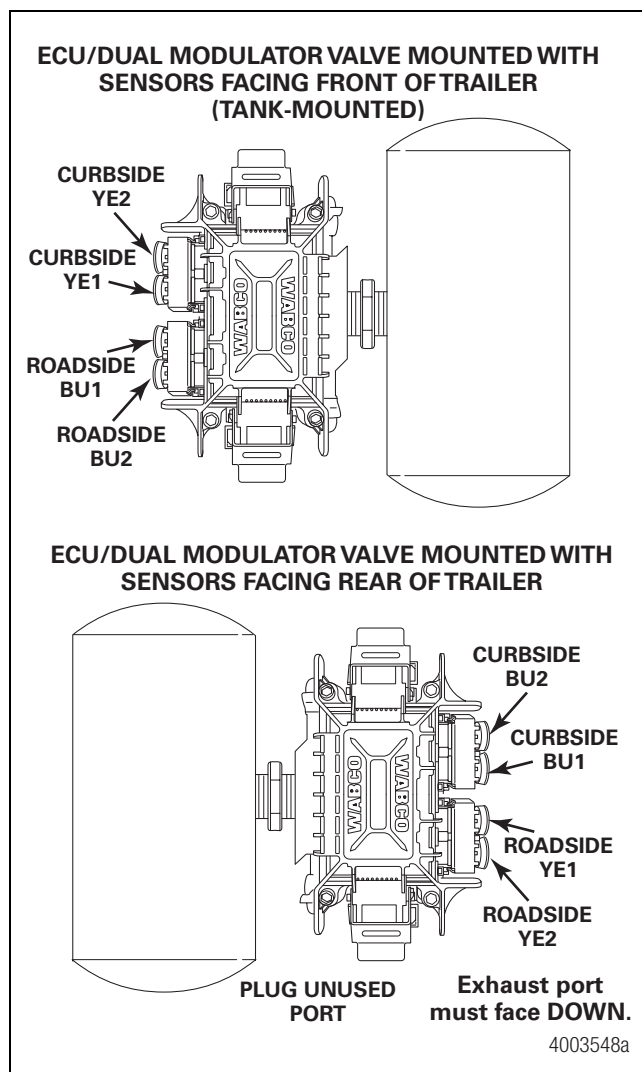

Figure 2

⚠ WARNING

You must use a Schedule 80 hex nipple (3/4-inch NPTF) to mount the ECU/dual modulator valve assembly securely to the air tank to avoid possible serious personal injury and damage to the component.

1. Use a 3/4-inch NPTF Schedule 80 hex nipple to attach the ECU/dual modulator valve assembly to a reinforced air tank. Do not overtighten.

Meritor WABCO does not recommend the use of a vise when installing the hex nipple. Use of a vise may cause overclamping. Overclamping may damage the internal components of the ECU/dual modulator valve assembly.
2. Use a 3/4-inch NPTF pipe plug to plug the unused supply port. Apply SAE-standard, DOT-approved Teflon tape or paste-type thread sealant to all pipe threads beyond the first two threads. Pipes with pre-applied thread sealant may also be used.
3. Rotate and tighten the ECU/dual modulator valve assembly until the exhaust port faces DOWN and the connection is secure. Use a torque wrench or ratchet with an extension at the 3/4-inch pipe plug installed on the front supply port.

Mounted to Cross Member of Vehicle (Mounting Bracket Not Supplied)

Refer to Figure 3.

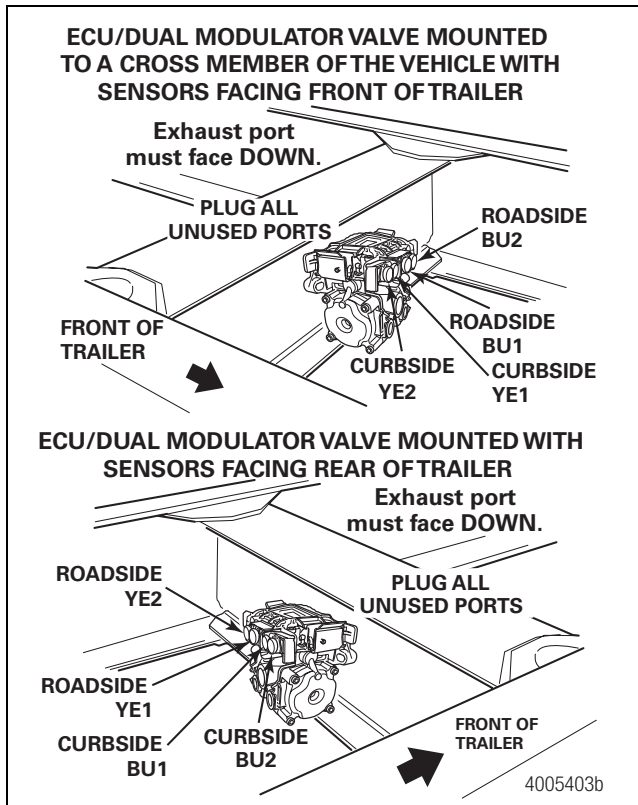

Figure 3

When mounting the ECU/dual modulator valve assembly to the trailer cross member, refer to SAE specification J447, Prevention of Corrosion of Motor Vehicle Body and Chassis Components. Follow all recommendations and procedures. Your supervisor should have a copy of this specification.

1. Install a 3/4-inch NPTF fitting in the supply port. Use a 3/4-inch NPTF pipe plug to plug the unused supply port (Port 1).

Apply SAE-standard, DOT-approved Teflon tape or paste-type thread sealant to all pipe plugs beyond the first two threads. Pipes with pre-applied thread sealant may also be used.
2. Locate a position for mounting the assembly to the vehicle cross member midway between the side rails, close to the brake chambers the valve serves.
 - Drill two 3/8-inch mounting holes. The distance between the two holes (O.D.) must be 6.06-inches (154 mm) and mount directly to the cross member.
 - OR
 - Build a mounting bracket with two 3/8-inch mounting holes spaced 6.06-inches (154 mm O.D.) apart.
3. Use two 3/8-inch Grade 8 bolts with prevailing torque nuts to attach the assembly. Tighten the bolts to 18 lb-ft (24 N•m). **⚠**

II. Attach the ABS external relay valve (4S/3M systems only).

Tank-Mounted

⚠ WARNING

You must use a Schedule 80 hex nipple (3/4-inch NPTF) to mount the ECU/dual modulator valve assembly securely to the air tank to avoid possible serious personal injury and damage to the component.

1. Use a 3/4-inch NPTF Schedule 80 hex nipple to attach the relay valve assembly to a reinforced air tank. Do not overtighten.

Meritor WABCO does not recommend the use of a vise when installing the hex nipple. Use of a vise may cause overclamping. Overclamping may damage the internal components of the ECU/dual modulator valve assembly.
2. Use a 3/4-inch NPTF pipe plug to plug the unused supply port. Apply SAE-standard, DOT-approved Teflon tape or paste-type thread sealant to all pipe threads beyond the first two threads. Pipes with pre-applied thread sealant may also be used.

3. Rotate and tighten the relay valve assembly until the exhaust port faces down and the connection is secure. Use a torque wrench or ratchet with an extension at the 3/4-inch pipe plug installed on the front supply port. Figure 4.

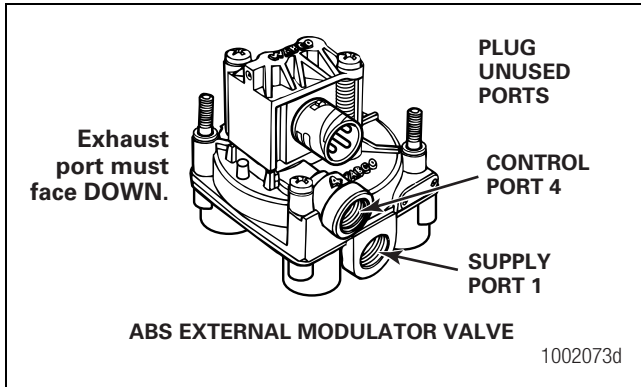



Figure 4

Mounted to Cross Member of Vehicle (Mounting Bracket Not Supplied)

When mounting the relay valve assembly to the trailer cross member, refer to SAE specification J447, Prevention of Corrosion of Motor Vehicle Body and Chassis Components. Follow all recommendations and procedures. Your supervisor should have a copy of this specification.

1. Install a 3/4-inch NPTF fitting in the supply port. Use a 3/4-inch NPTF pipe plug to plug the unused supply port (Port 1).
 - Apply SAE-standard, DOT-approved Teflon tape or paste-type thread sealant to all pipe plugs beyond the first two threads. Pipes with pre-applied thread sealant may also be used.
2. Install the valve with two locknuts and washers as required. Tighten the hex nuts to 18 lb-ft (24 N•m). 

III. Connect the air lines.

Before connecting the air lines, plumb the spring brake relay or emergency brake relay into the system as usual.

- If you are mounting on a bracket, connect the air supply line from the supply tank to the supply Port 1. Plug the unused port.
 - Use 5/8-inch O.D. min. nylon tubing or heavy-walled Schedule 80 pipe nipple (3/4-inch NPTF) if you are mounting directly to the supply tank.
1. Connect the air delivery lines to the ECU/dual modulator valve assembly Port 2. For 4S/3M installations, connect the air delivery lines to Port 2 on the external relay valve (3/8-inch NPTF).

2. Connect the air delivery lines to the appropriate brake chambers (3/8-inch NPT). Figure 5 and Figure 6.
 - The valve portion of the ECU/dual modulator valve assembly contains two separate valves: one dedicated to roadside wheel ends, the other dedicated to curbside wheel ends. Each valve has three delivery ports.
 - The external relay valve designated RED (RD) is an axle control valve. It controls brake chambers on one or two axles. It is important that delivery lines from Port 2 are plumbed as shown. Refer to Figure 13 through Figure 19.

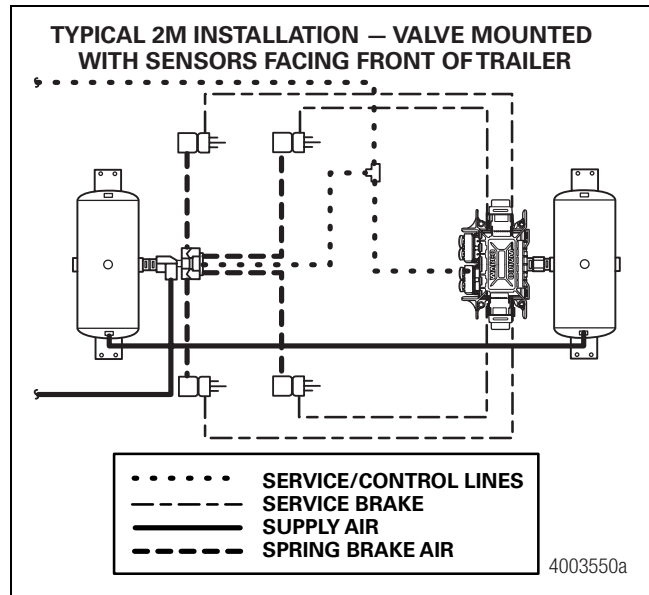

Figure 5

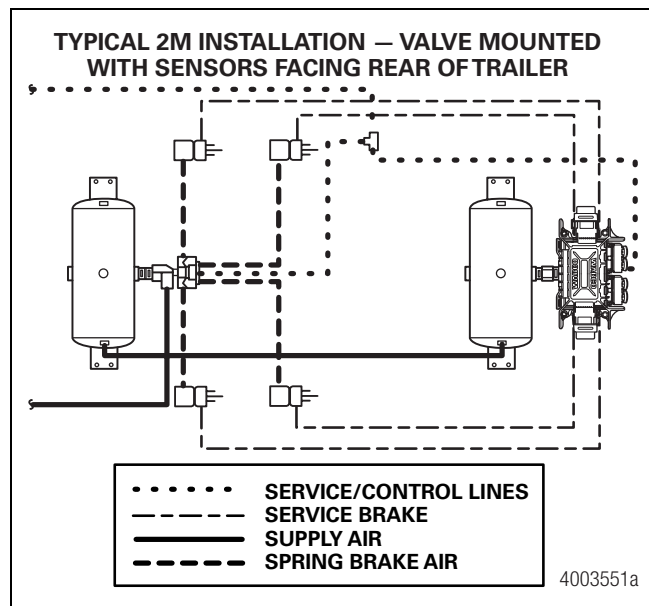

Figure 6

3. Connect the brake service (control) line to the ECU/dual modulator valve assembly Port 4 (1/4-inch NPTF).
4. For 4S/3M installations, perform the following procedures.
 - A. Connect the brake service (control) line to the ECU/dual modulator valve assembly Port 4 (1/4-inch NPTF) and ABS external relay valve control Port 4 (3/8-inch NPTF).
 - B. Use an ABS relay valve connection cable to connect the ECU/dual modulator valve assembly with the ABS external relay valve.
5. Plug any unused delivery ports.

IV. Install the sensor extension cables (ABS-prepped axles).

Instructions for installing sensors on non-ABS-prepped axles are included in the Appendix.

Meritor WABCO recommends placing sensors on the axle that will provide the most braking performance. The suspension manufacturer can provide this information.

1. Visually inspect the tooth wheel and sensor to ensure no damage occurred during shipping. Perform any necessary repairs.
2. Connect the sensors and cables on the prepped axles to the sensor extension cables. Figure 7.

Ensure that each connection is secure.

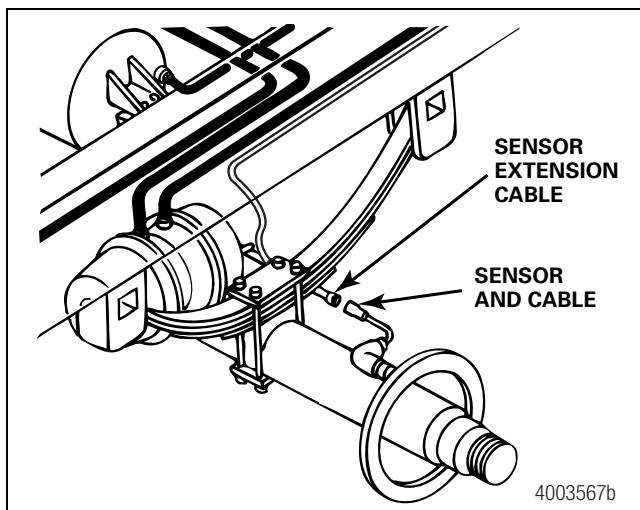

Figure 7

3. Route the sensor cable along the back side of the trailer axle to the ECU/dual modulator valve assembly. Route the cable with the brake hose.

Do not overtighten the tie wraps on a cable. Overtightening can damage the cable. Do not tie wrap the molded sensor plug. The sensor extension cable must follow the brake hose to the ECU/dual modulator valve assembly to allow for axle jounce and rebound.

4. Secure the cables every eight inches (203 mm) with tie wraps or cable clips.
5. Push the sensor retainer clip on the ECU/dual modulator valve assembly UP.
6. Remove the protective caps from YE2 and YE1 sensor connectors.
7. Plug the sensor extension cables into the ECU/dual modulator valve assembly. To secure the connection, push the sensor retainer clip DOWN. Retainer clips must fit in the groove of the sensor connectors to ensure correct connection.

ECU/Dual Modulator Valve Assembly Mounted with Sensors Facing Front of Trailer

- 2S/2M
 - Connect curbside sensor at YE1.
 - Connect roadside sensor at BU1.
- 4S/2M*
 - Connect curbside front sensor at YE1.
 - Connect curbside rear sensor at YE2.
 - Connect roadside front sensor at BU1.
 - Connect roadside rear sensor at BU2.
- 4S/3M* — Sensor locations vary by type of installation. Refer to the diagrams on the following pages for specific sensor locations.

For Enhanced Easy-Stop™ 4S/3M lift axle installations, you must use TOOLBOX™ Software, version 4.6 or higher, to enable the lift axle function. It is not automatically enabled. Refer to Enabling the Lift Axle Function (4S/3M Installations) in the Appendix for instructions.

It is not automatically enabled. Refer to Enabling the Lift Axle Function (4S/3M Installations) in the Appendix for instructions.

- Connect curbside sensor at YE1.
- Connect curbside sensor at YE2.
- Connect roadside sensor at BU1.
- Connect roadside sensor at BU2.

* **If the lift axle is sensed in 4S/2M and 4S/3M installations:** Sensors YE2 and BU2 must always be used on the lift axle to avoid an unwanted ABS indicator lamp illumination.

ECU/Dual Modulator Valve Assembly Mounted with Sensors Facing Rear of Trailer

- 2S/2M
 - Connect curbside sensor at BU1.
 - Connect roadside sensor at YE1.
- 4S/2M*
 - Connect curbside front sensor at BU1.
 - Connect curbside rear sensor at BU2.
 - Connect roadside front sensor at YE1.
 - Connect roadside rear sensor at YE2.
- 4S/3M* — Sensor locations vary by type of installation. Refer to the diagrams for specific sensor locations.

For Enhanced Easy-Stop™ 4S/3M lift axle installations, you must use TOOLBOX™ Software, version 4.6 or higher, to enable the lift axle function. It is not automatically enabled. Refer to Enabling the Lift Axle Function (4S/3M Installations) in the Appendix for instructions.

- Connect curbside sensor at BU1.
- Connect curbside sensor at BU2.
- Connect roadside sensor at YE1.
- Connect roadside sensor at YE2.

* **If the lift axle is sensed in 4S/2M and 4S/3M installations:** Sensors YE2 and BU2 must always be used on the lift axle to avoid an unwanted ABS indicator lamp illumination.

8. Create a strain relief to protect the sensor extension connector terminals. Without this strain relief, normal trailer jounce and vibration will cause the terminals to spread and loosen. Use a tie wrap or clip to secure the cable to the brake air delivery hose as close to the fitting as possible. Figure 8.

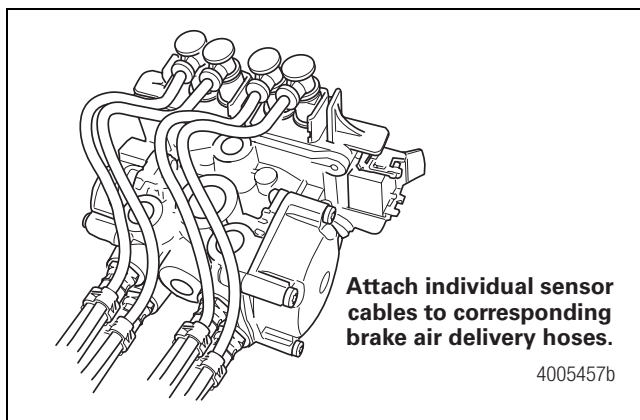

Figure 8

9. Bundle any excess cable in a loop (bow tie). Figure 9.

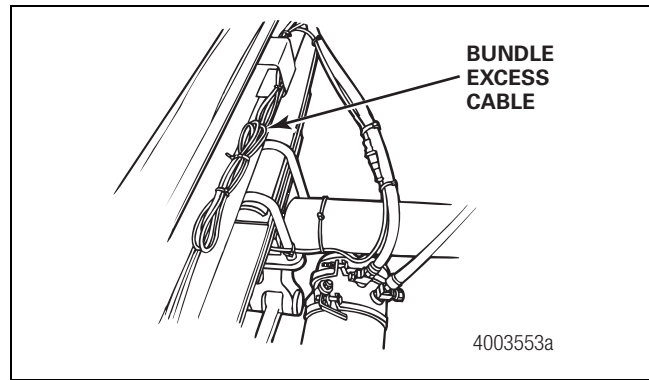

Figure 9

10. Secure excess cable in the sub-frame of the vehicle or along the air hoses as appropriate. Excess cable should not exceed two feet (0.61 meter).

Various cable lengths are available.

V. Install the power and lamp or power and lamp/diagnostic cable.

1. Identify the type of cable to be installed. Figure 10.
 - ABS trailer industry-standard pigtail connector power cable
 - Blunt-cut power cable (not shown)

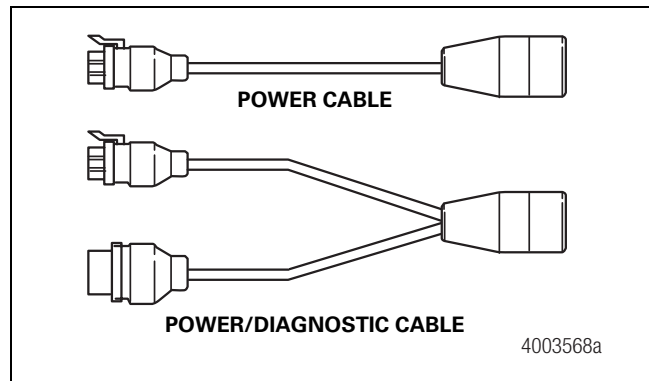

Figure 10

2. For industry-standard pigtail connector power cables, route the cable from the harness connector to the ECU/dual modulator valve assembly and secure it to prevent damage.

For blunt-cut power cables, route the cable from the ECU/dual modulator valve assembly to a junction box which interfaces with the seven-way connector at the front of the trailer.

Leave enough slack in the cable to compensate for flexing of the trailer and sub-frame.

3. Bundle any excess cable in a loop (bow tie) and secure it in the sub-frame of the trailer body to prevent cable damage.
4. Push the hinged power/diagnostic connector retainer clip UP and remove the protective cap from the ECU/dual modulator valve assembly. Figure 11.

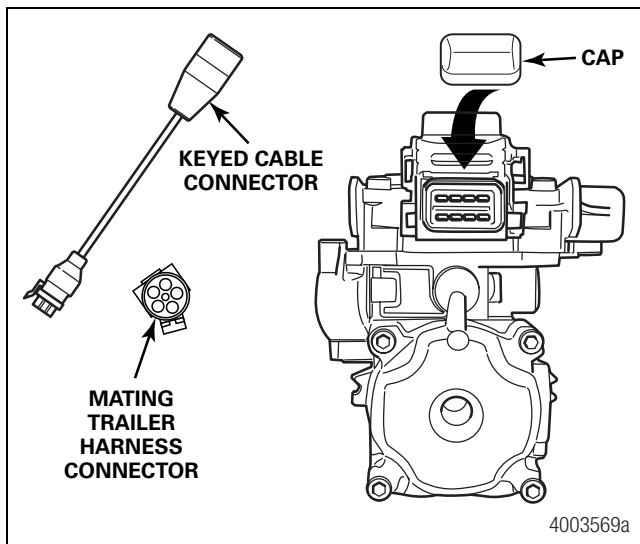

Figure 11

5. Plug the power 8-pin connector on the power or power/diagnostic cable into the ECU/dual modulator valve assembly.
6. Pull the hinged power/diagnostic connector retainer clip on the ECU/dual modulator valve assembly DOWN to secure the connection.
7. If you are installing the power cable only, go to Step 9.

8. If you are installing the power/diagnostic "Y" cable:
 - A. Install the diagnostic cable bracket so that the diagnostic plug is accessible. The normal location is on the right front corner of the sub-frame, but will vary depending on the type of trailer.
 - B. Route the diagnostic cable from the ECU/dual modulator valve assembly to the diagnostic cable bracket.
 - C. Correctly secure the cable in the sub-frame to prevent cable damage.
Leave enough slack in the cable to compensate for flexing of the trailer and sub-frame.
 - D. Bundle excess cable in a loop (bow tie) and secure the cable in the sub-frame. Figure 9.

9. Install the ABS indicator lamp on the trailer. Refer to the vehicle specification sheet for the exact location of the indicator lamp. Use a DOT-approved lamp with ABS etched on the lens (available from major trailer parts suppliers).

To ensure correct lamp operation, use an incandescent-type DOT-approved lamp or an LED with integral load resistor.

If you are using the industry-standard connector cable and do not have access to the mating trailer harness, mask the open connector to protect it from paint or grease.

10. Connect the power. Use the industry-standard connector cable or a blunt-cut power cable.

For industry-standard connector cables: Attach the power cable to the harness on the trailer.

For an optional blunt-cut power cable: Wire the cable and ABS indicator lamp to the seven-way connector on the trailer according to the following diagram. Figure 12.

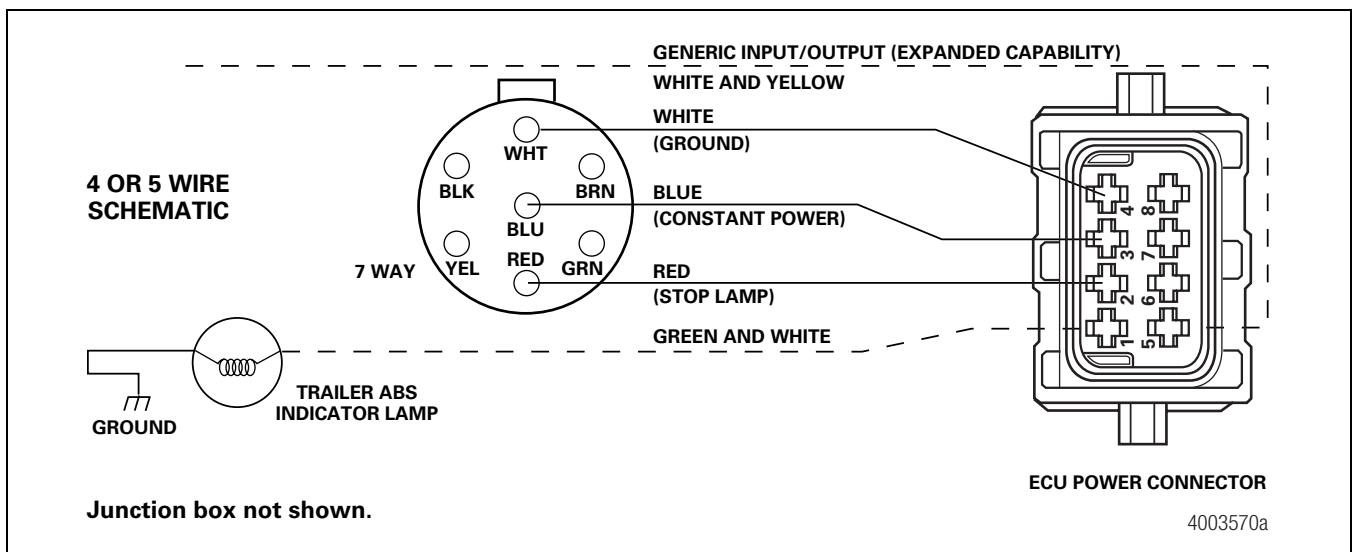

Figure 12

Typical Easy-Stop™ Trailer ABS Installations

Refer to Figure 13 through Figure 19 for typical Easy-Stop™ trailer ABS installations.

Meritor WABCO recommends placing sensors on the axle that will provide the most braking performance. The suspension manufacturer can provide this information.

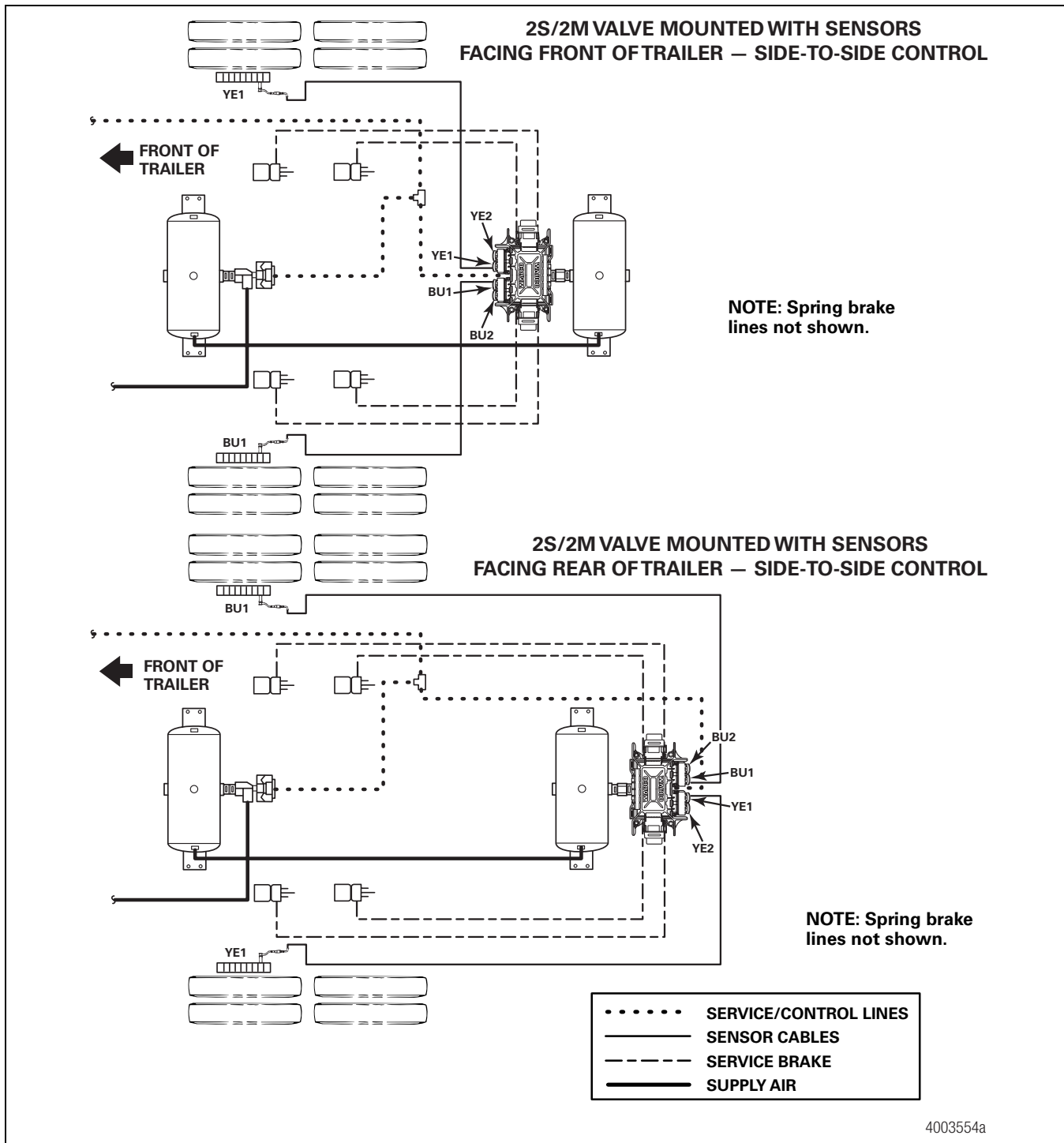

Figure 13

Meritor WABCO recommends placing sensors on the axle that will provide the most braking performance. The suspension manufacturer can provide this information.

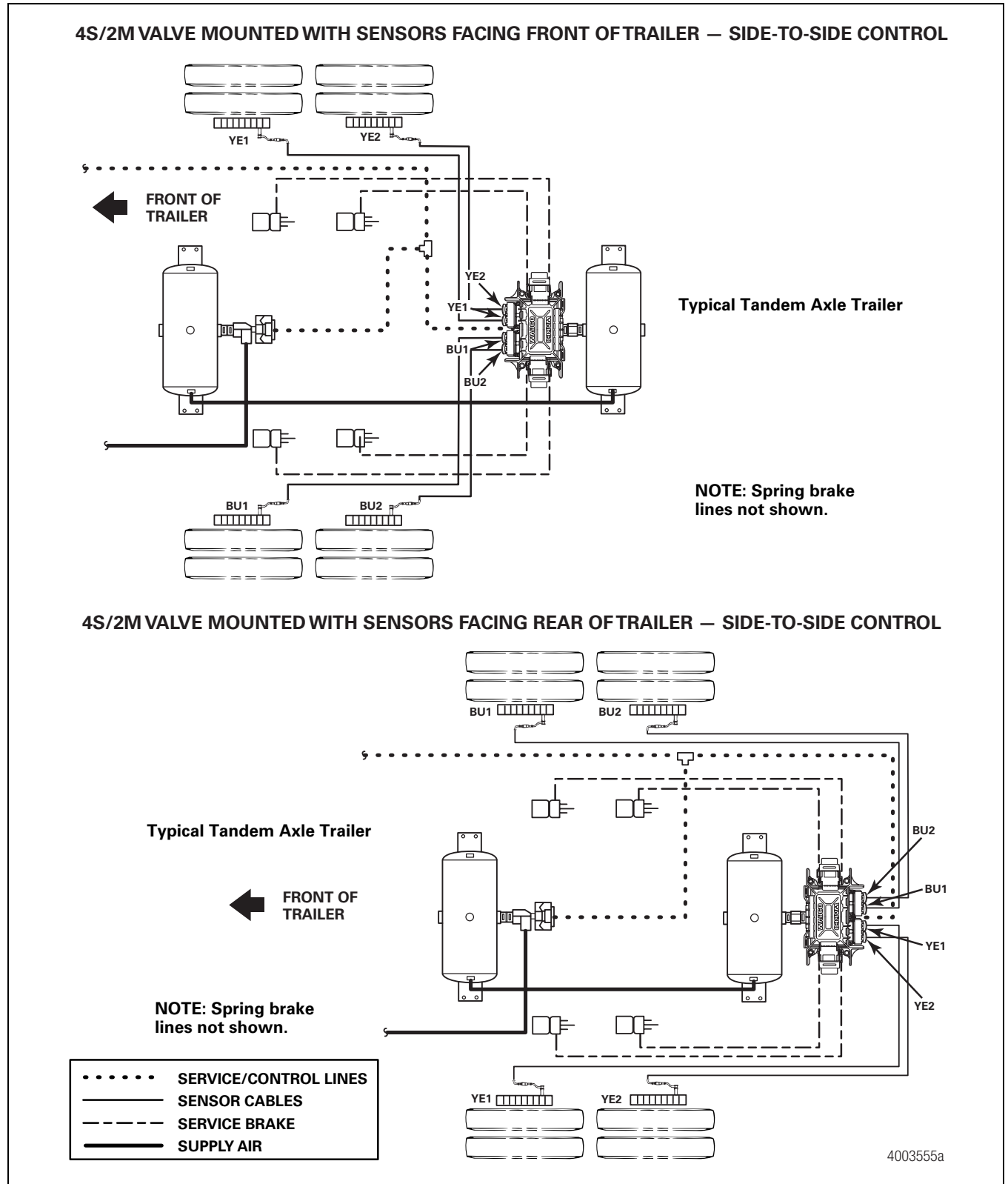
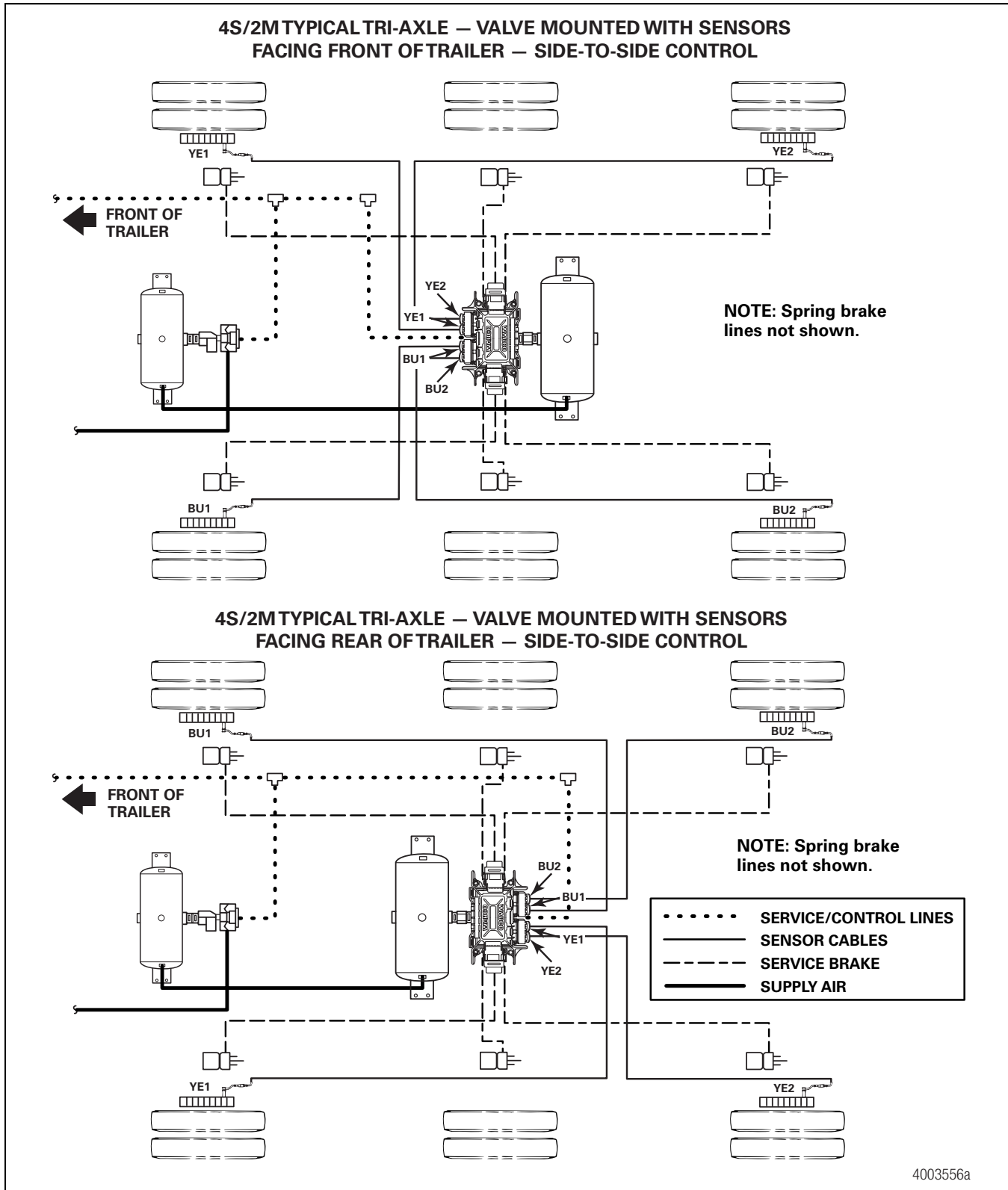

Figure 14

Meritor WABCO recommends placing sensors on the axle that will provide the most braking performance. The suspension manufacturer can provide this information.



4003556a

Figure 15

Meritor WABCO recommends placing sensors on the axle that will provide the most braking performance. The suspension manufacturer can provide this information.

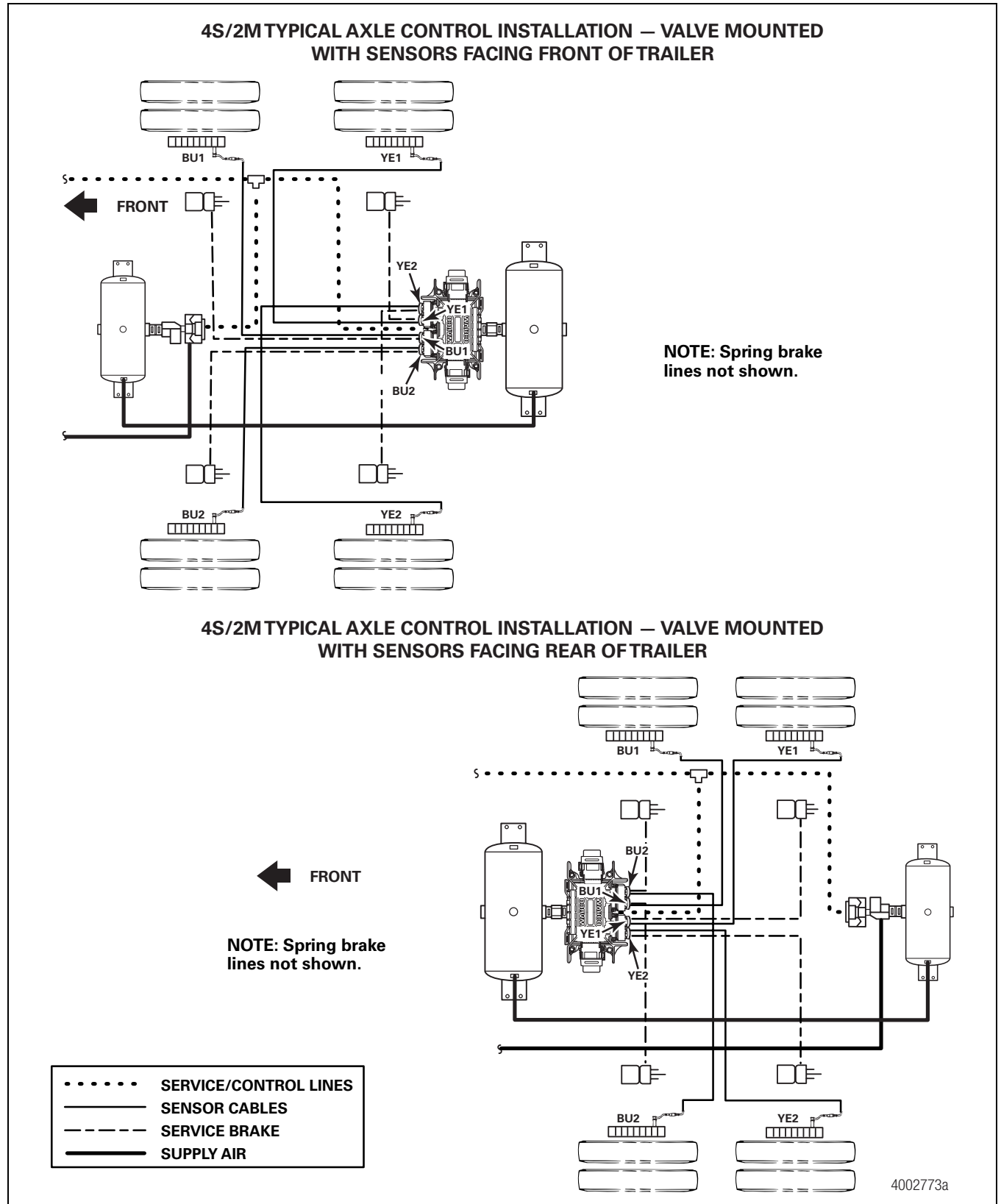

Figure 16

NOTE: For Enhanced Easy-Stop™ 4S/3M lift axle installations, you must use TOOLBOX™ Software, version 4.6 or higher, to enable the lift axle function. It is not automatically enabled. Refer to Enabling the Lift Axle Function (4S/3M Installations) in the Appendix for instructions.

Meritor WABCO recommends placing sensors on the axle that will provide the most braking performance. The suspension manufacturer can provide this information.

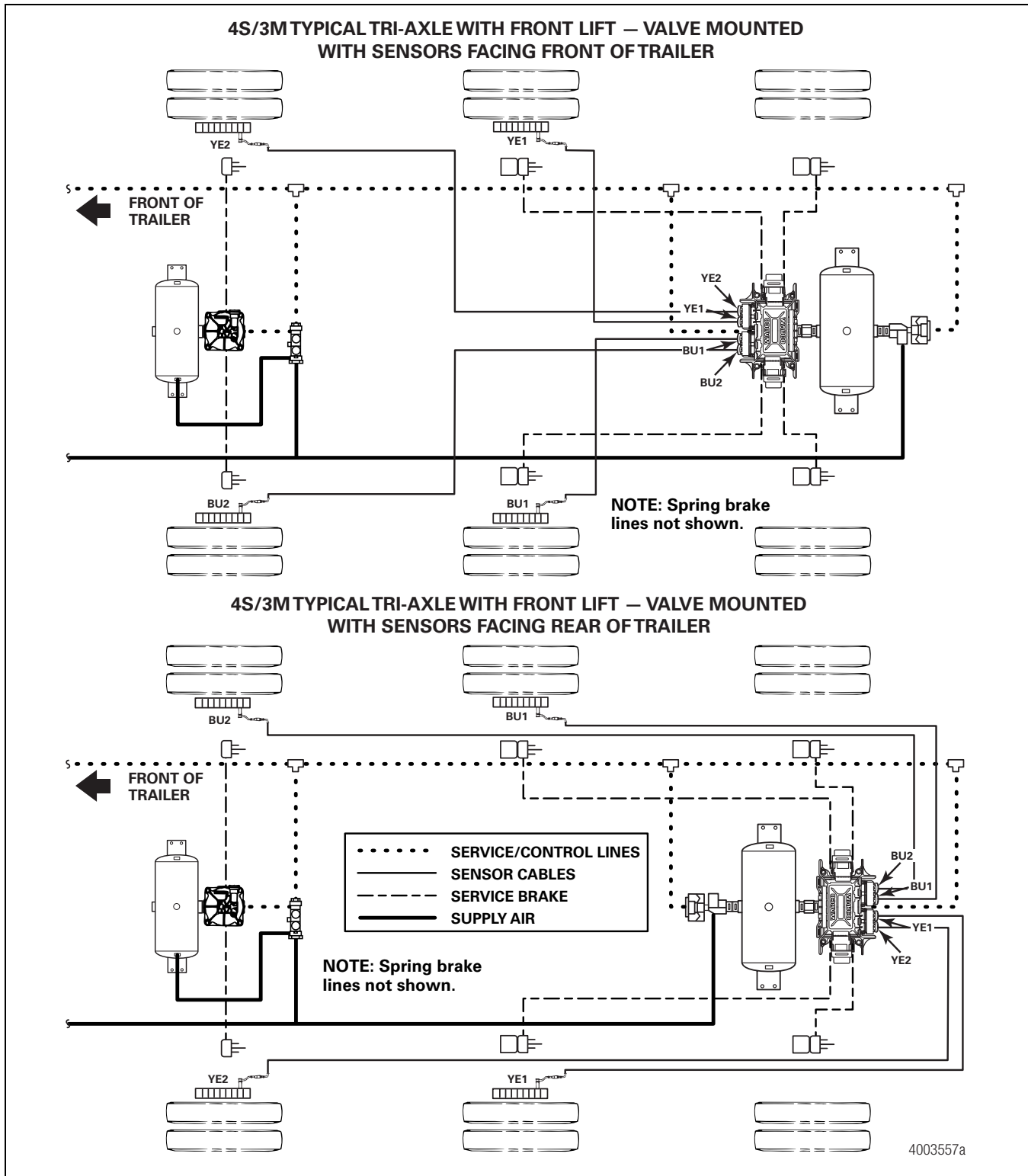

Figure 17

Meritor WABCO recommends placing sensors on the axle that will provide the most braking performance. The suspension manufacturer can provide this information.

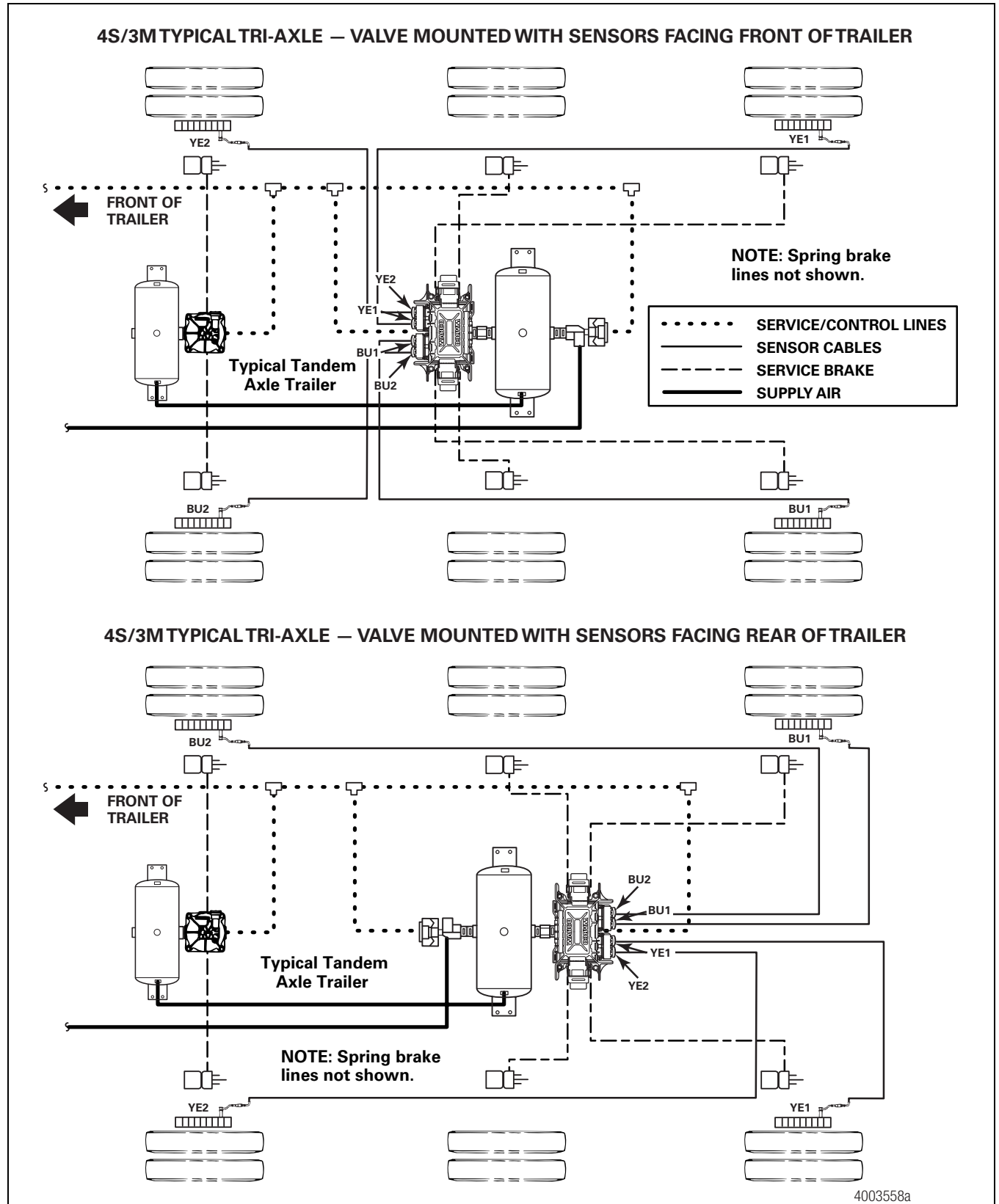

Figure 18

Meritor WABCO recommends placing sensors on the axle that will provide the most braking performance. The suspension manufacturer can provide this information.

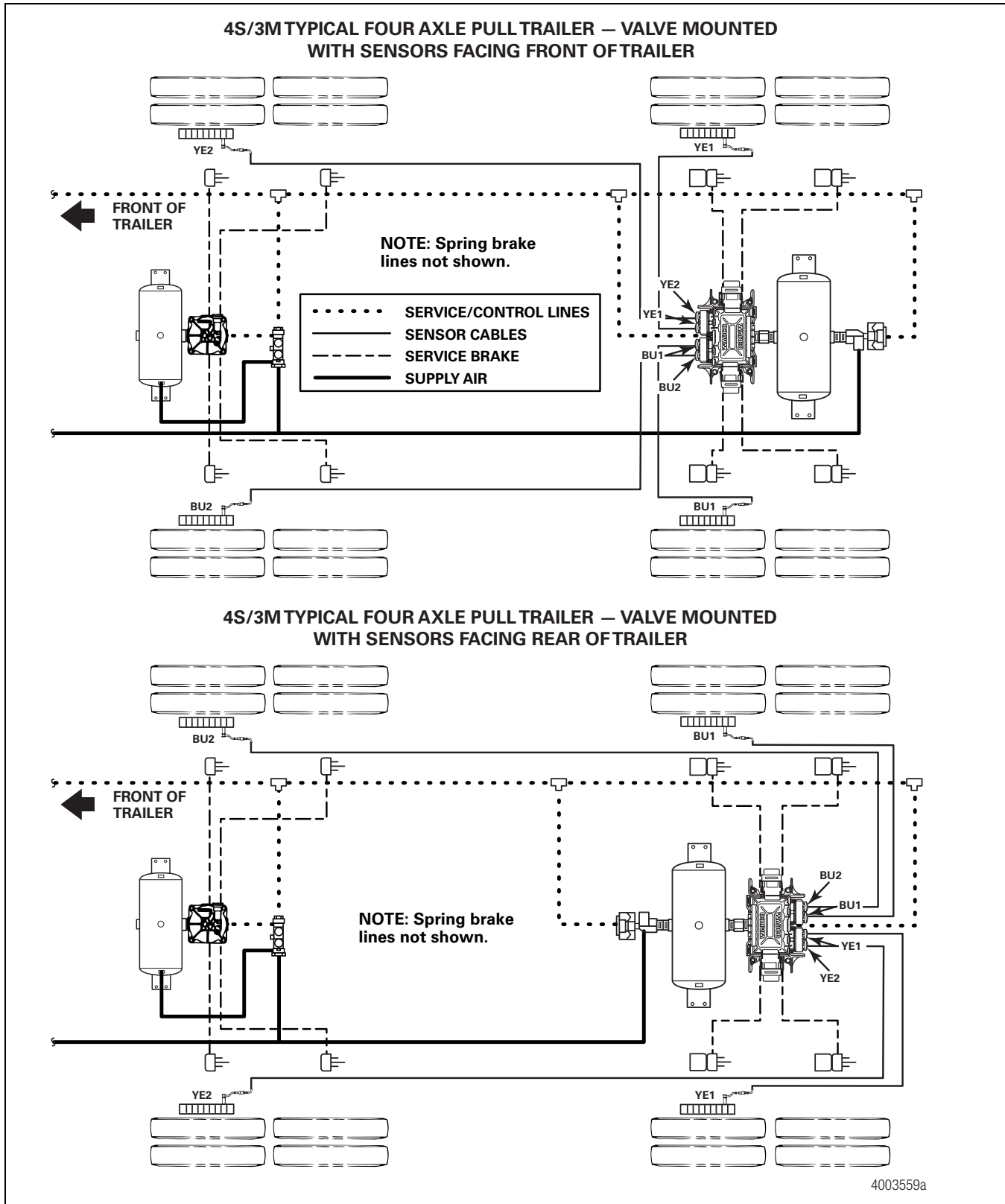

Figure 19

End of Line Testing

End of line testing is required on all Enhanced Easy-Stop™ installations. To run these tests, Meritor WABCO recommends you use TOOLBOX™ Software.

TOOLBOX™ Software and general test procedures are included in this bulletin. If you are using a Pro-Link, refer to the operating manual for test instructions.

Enhanced Easy-Stop™ 2S/2M, 4S/2M and 4S/3M Premium Installation — End of Line Testing Procedure with TOOLBOX™ Software

If you are testing an installation that has a power only cable, temporarily install a Meritor WABCO combination power/diagnostics “Y” style cable.

1. Connect the diagnostic connector on the cable to the PC serial port/SAE diagnostic interface (J1587/J1708 to RS232 interface).

Refer to the Software Owner’s Manual, TP-99102, for instructions for running TOOLBOX™ Software.

2. Display the **Trailer ABS Main Screen**.
3. Verify the power supply.
 - Apply 12 volts DC to the blue wire (constant). Check the screen for the correct voltage (9.5 to 14 volts). Constant power voltage is displayed in the PRIMARY field. Figure 20.
 - Apply 12 volts DC to the red wire (stoplight power). Check the screen for the correct voltage (9.5 to 14 volts). Stoplight power voltage is displayed in the SECONDARY field. Figure 20.

The internal field is not applicable to this test.

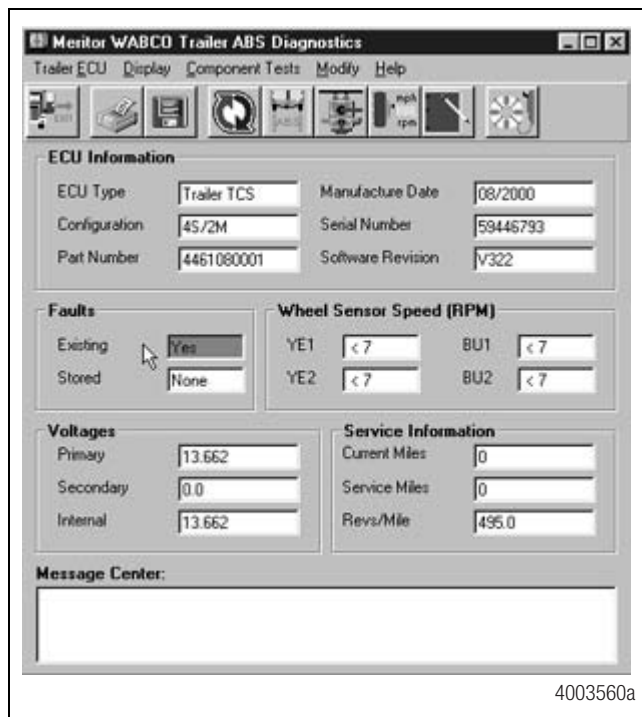

Figure 20

4. Check the Faults field on the Main Screen.
NONE = No faults present, proceed with end of line test.

YES = Faults present, double-click on “YES” to bring up the fault information screen.

Use the information in the **Repair Instructions** field to perform the necessary repairs. Figure 21.

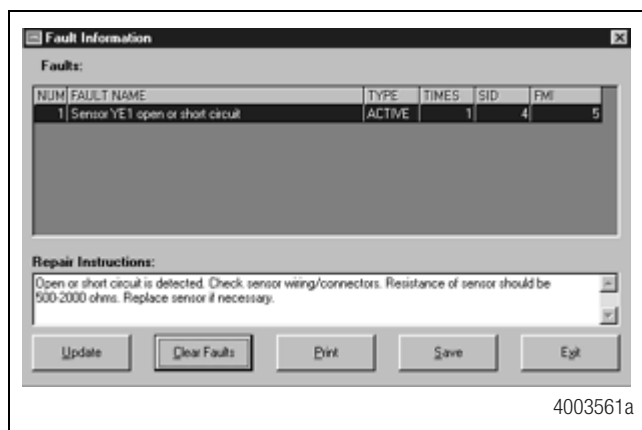

Figure 21

End of Line Test with TOOLBOX™ Software

Verify Correct Valve and Lamp Installation

To verify valve and lamp installations with TOOLBOX™ Software:

1. Apply 12 volts DC to the ABS.
2. Apply air to the emergency line to fill the air tanks and release the spring brakes.
3. Apply air to the control line.
4. At the **Trailer Main Screen**, click on **Component Test**, then select **Valves/Lamp** to display the **Valve Activation Screen**. The **Yellow** valve indicator will be highlighted. Figure 22.



Figure 22

5. Click on the **Activate** button.
6. Check for correct air line installation. To accomplish this, observe the slack adjusters.
 - If the ECU faces the **FRONT** of the trailer, the slack adjusters will move in and out as the **CURBSIDE** portion of the dual modulator valve cycles. If this does not happen, the air lines are not correctly connected. Perform the necessary repairs.
 - If the ECU faces the **REAR** of the trailer, the slack adjusters will move in and out as the **ROADSIDE** portion of the dual modulator valve cycles. If this does not happen, the air lines are not correctly connected. Perform the necessary repairs.

The Test Status box at the bottom of the menu will display the status of this test.

7. Repeat this test for the Blue valve.
 - A. Repeat Steps 1-3.
 - B. Select the Blue valve from the valve activation screen.
 - C. Click on the **Activate** button to verify correct valve installation (Blue).
 - D. Check for correct air line installation. To accomplish this, observe the slack adjusters.
 - If the ECU faces the **FRONT** of the trailer, the slack adjusters will move in and out as the **ROADSIDE** portion of the dual modulator valve cycles. If this does not happen, the air lines are not correctly connected. Perform the necessary repairs.
 - If the ECU faces the **REAR** of the trailer, the slack adjusters will move in and out as the **CURBSIDE** portion of the dual modulator valve cycles. If this does not happen, the air lines are not correctly connected. Perform the necessary repairs.

8. **For 4S/3M installations:** Repeat this test for the red valve.

Red: The external relay valve designated RED (RD) is an axle control valve. It controls brake chambers on one or two axles. It is important that delivery lines from Port 2 are plumbed as shown on the installation drawings. The 4S/3M system is designed to be used with a variety of trailer configurations. Call ArvinMeritor's Customer Service Center at 800-535-5560 for additional information.

9. Click on the **Test** button to activate the ABS indicator lamp — this is the lamp that is mounted on the side of the trailer. The lamp will flash eight times, indicating lamp installation is OK. The **Test Status** box at the bottom of the menu will display the status of this test. Figure 22.
10. Click on **Close** to exit.

Sensor Orientation Test

This test is not for use on 4S/3M installations.

For **4S/3M installations**, use the standard **Sensor Test**. To run the standard test, select **Sensor Test** from the **Components Test Menu**.

The sensor orientation test must be performed as part of the end of line testing procedure.

Sensor Orientation Test Screen

Before beginning this test, look at the ECU to see if the sensors face the front or rear of the trailer. TOOLBOX™ will ask for this information to start the test (Step 5). To perform the sensor orientation test:

1. Raise the sensed wheel ends off the ground.
2. Apply air to the emergency line to fill the air tanks and release the spring brakes so that the wheels can be rotated.
3. Apply 12 volts DC to the ABS.
4. At the **Trailer Main Menu**, click on **Component Test**, then select **Sensor Orientation Test** to display the **Sensor Orientation Test** screen. Figure 23.

When the **Sensor Orientation Test** screen first appears, the **Sensors Facing** field will display the default — **Front**. This will occur regardless of the actual sensor orientation of the installation being tested.

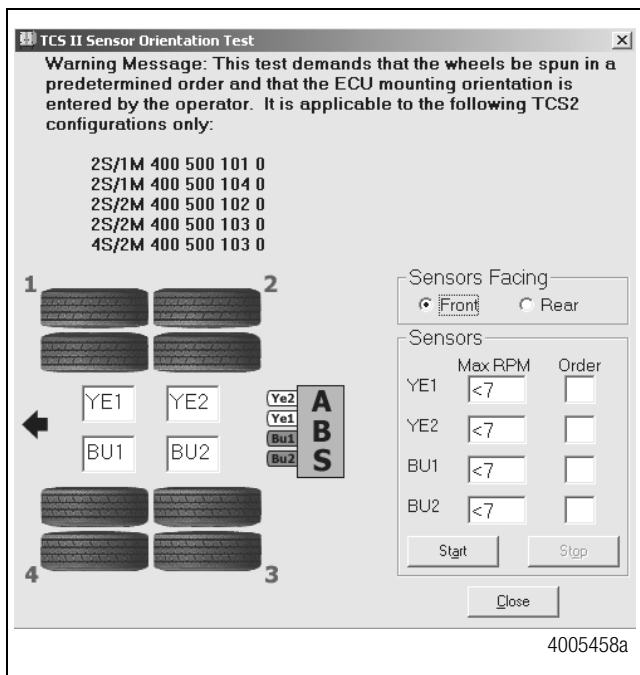

Figure 23

5. Click on **Front** or **Rear** in the **Sensors Facing** field to select the mounting orientation of the ECU/dual modulator valve assembly. Figure 24.

Refer to Figure 23 and Figure 24 for illustrations of the ECU mounted with sensors facing forward and rear. The correct mounting orientation must be selected prior to starting the test (Step 5).

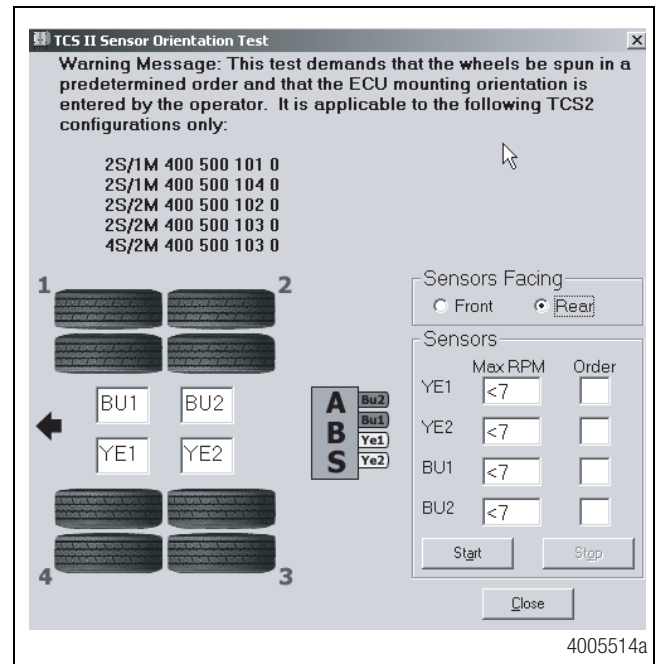

Figure 24

NOTE: 2S/2M installations use YE1 and BU1 locations.

6. Click on **Start** to begin the test. Figure 25.

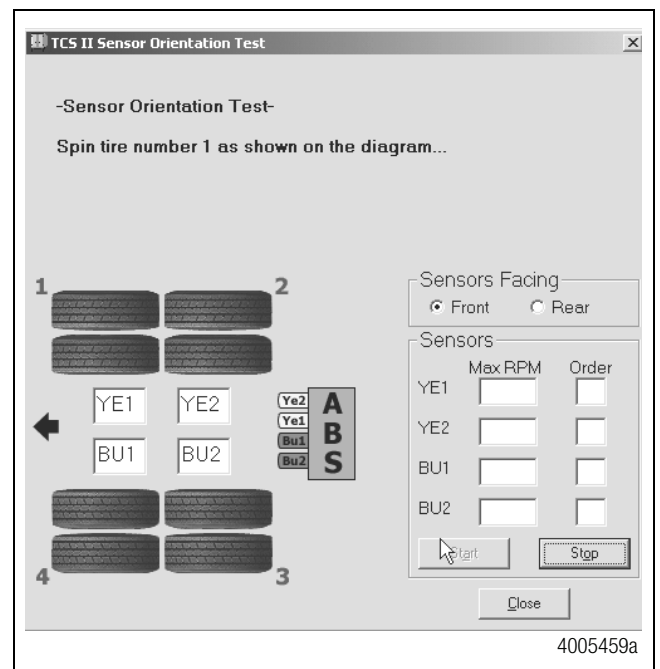

Figure 25

7. Follow the screen prompts, starting with 1, to rotate each sensed wheel end at a rate of 1/2 revolution per second. This rate equals a wheel speed of approximately 4 mph (7 kph). As each sensed wheel is rotated, check the color of the sensor identification block on the screen for results. Sensor identification boxes are located in the bottom left portion of the **Sensor Orientation Test** screen. Figure 24.

Green background: Correct sensor location. Spin the next sensed wheel as indicated by the screen prompt.

Red background: Incorrect sensor location. If you get a red background, you must stop the test (click on stop), make the necessary corrections and repeat Steps 3 through 6.

8. To finish the Sensor Orientation Test, click on **Stop**, then on **Close**.
9. Verify there is sensor output. If there is no sensor output, verify that a tone ring has been installed and that the sensor is pushed all the way in against the tone ring. Perform the necessary repairs and repeat the test. If the problem persists, contact Meritor WABCO (800-535-5560). Sensor output appears in the Sensors field located in the bottom right portion of the **Sensor Orientation Test** screen. Figure 24.

End of Line Testing without TOOLBOX™ Software

Sensor Installation

1. Look at the sensor connectors on the ECU/dual modulator valve assembly. Ensure that the connectors are routed to the correct wheel-end location, as follows:

ECU/Dual Modulator Valve Assembly Mounted with Sensors Facing Front of Trailer

- 2S/2M
 - Connect curbside sensor at YE1.
 - Connect roadside sensor at BU1.
- 4S/2M*
 - Connect curbside front sensor at YE1.
 - Connect curbside rear sensor at YE2.
 - Connect roadside front sensor at BU1.
 - Connect roadside rear sensor at BU2.

- 4S/3M* — Sensor locations vary by type of installation. Refer to the diagrams for specific sensor locations.

For Enhanced Easy-Stop™ 4S/3M lift axle

installations, you must use TOOLBOX™ Software, version 4.6 or higher, to enable the lift axle function. It is not automatically enabled. Refer to Enabling the Lift Axle Function (4S/3M Installations) in the Appendix for instructions.

- Connect curbside sensor at YE1.
- Connect curbside sensor at YE2.
- Connect roadside sensor at BU1.
- Connect roadside sensor at BU2.

ECU/Dual Modulator Valve Assembly Mounted with Sensors Facing Rear of Trailer

- 2S/2M
 - Connect curbside sensor at BU1.
 - Connect roadside sensor at YE1.
- 4S/2M*
 - Connect curbside front sensor at BU1.
 - Connect curbside rear sensor at BU2.
 - Connect roadside front sensor at YE1.
 - Connect roadside rear sensor at YE2.
- 4S/3M* — Sensor locations vary by type of installation. Refer to the diagrams for specific sensor locations.

For Enhanced Easy-Stop™ 4S/3M lift axle

installations, you must use TOOLBOX™ Software, version 4.6 or higher, to enable the lift axle function. It is not automatically enabled. Refer to Enabling the Lift Axle Function (4S/3M Installations) in the Appendix for instructions.

- Connect curbside sensor at BU1.
- Connect curbside sensor at BU2.
- Connect roadside sensor at YE1.
- Connect roadside sensor at YE2.

*** If the lift axle is sensed in 4S/2M and 4S/3M installations:**

Sensors YE2 and BU2 must always be used on the lift axle to avoid an unwanted ABS indicator lamp illumination.

2. If sensors are not correctly installed, perform the necessary repairs.

Air Line Installation

1. Ensure that all unused air ports are plugged and that the exhaust port is facing DOWN.
2. Look at the air line installation to verify that all air lines are correctly installed.
 - If the ECU/dual modulator valve assembly is mounted with the sensors facing the FRONT of the trailer, the air lines for the three delivery ports located under the YE sensor connectors must be routed to CURBSIDE; the air lines for the three delivery ports on the opposite side of the valve must be routed to roadside. Figure 26.
 - If the ECU/dual modulator valve assembly is mounted with the sensors facing the REAR of the trailer, the air lines for the three delivery ports located under the YE sensor connectors must be routed to ROADSIDE; the air lines for the three delivery ports on the opposite side of the valve must be routed to curbside. Figure 27.

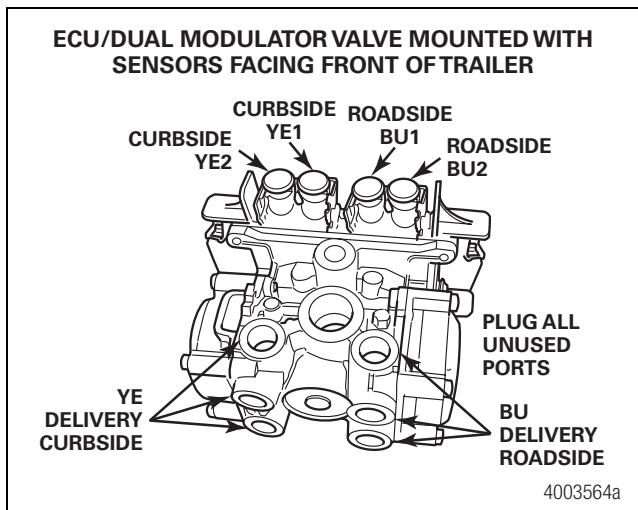

Figure 26

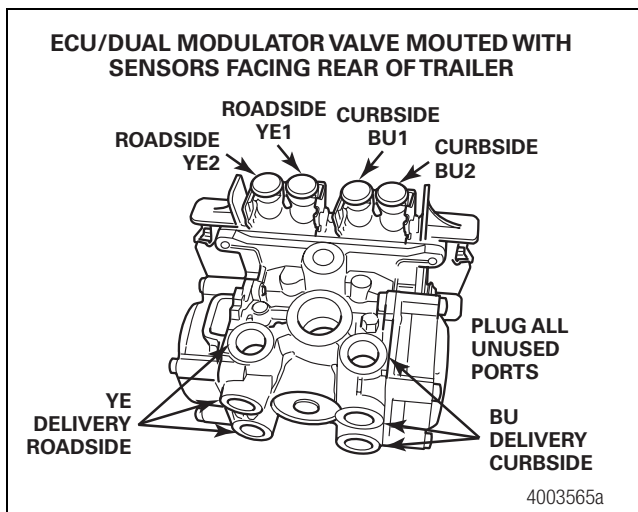

Figure 27

3. **For 4S/3M installations:** Repeat this test for the red valve.

Red: The external relay valve designated RED (RD) is an axle control valve. It controls the brake chambers on one or two axles. It is important that delivery lines from Port 2 are plumbed as shown in Figure 17, Figure 18 and Figure 19. The 4S/3M system is designed to be used with a variety of trailer configurations. Call ArvinMeritor's Customer Service Center at 800-535-5560 for additional information.
4. If the air lines are not correctly routed, perform the necessary repairs.

Perform End of Line Test

1. Apply 12 volts DC power to the ABS.
2. Listen for the ECU/dual modulator valve assembly to click four times (six times for a 4S/3M).
3. If the indicator lamp **comes on** for three seconds then **goes out**, this indicates a correct installation. The end of line test is complete.

If the ABS indicator lamp **comes on** and **stays on**, check the sensor installation.

- A. Remove the power from the ABS and raise the sensed wheels so they may be rotated.
- B. Apply emergency air to fill the air tanks and release the spring brakes so that the wheels may be rotated.
- C. Repeat Steps 1 and 2.
- D. Rotate each sensed wheel — one at a time — at a rate of 1/2 revolution per second. This rate equals a wheel speed of approximately 4 mph (7 kph).

The ABS indicator lamp should now go out and stay out indicating a correct installation. The end of line test is complete.

4. If the ABS lamp does not go out, there is a sensor gap problem or hardware fault. Adjust the sensor and, if necessary, perform a fault code check.

Sensor Gap Adjustment

Push the sensor into its holder until it contacts the tooth wheel. At installation, there must be no gap between the sensor and the tooth wheel.

Measure the AC voltage output. The value should be 0.2 volt AC when the wheel is rotated at a rate of 1/2 revolution per second.

Perform any necessary repairs.

Repeat the end of line test. If the trailer lamp still does not go out, a system fault exists. Perform a fault code check.

Fault Code Check

Use constant power activation to perform the following fault code check.

1. Apply constant power to the ECU/dual modulator valve assembly for more than one, but less than five seconds.
2. Remove the power.
3. Reapply the power.
4. Check the trailer ABS indicator lamp on the side of the trailer. The fault code will be displayed three times.
5. Find the fault on the chart and perform the necessary repairs.
6. After performing the necessary repairs, repeat the end of line test.

Blink Code Chart		
Blink Code	Problem Area	Action
3	Sensor BU1	Determine sensor location. Check sensor installation. Perform necessary repairs.
4	Sensor YE1	Determine sensor location. Check sensor installation. Perform necessary repairs.
5	Sensor BU2	Determine sensor location. Check sensor installation. Perform necessary repairs.
6	Sensor YE2	Determine sensor location. Check sensor installation. Perform necessary repairs.
7	External ABS modulator valve	Verify correct electrical installation. Check power supply. Perform necessary repairs.
9	Internal modulator failure, inlet valve #2	Verify correct installation. If code continues, contact Meritor WABCO for assistance.
10	Internal modulator failure, inlet valve #1	Verify correct installation. If code continues, contact Meritor WABCO for assistance.
11	Internal modulator failure, outlet valve	Verify correct installation. If code continues, contact Meritor WABCO for assistance.

Blink Code Chart		
Blink Code	Problem Area	Action
14	Power Supply	Verify correct electrical installation. Check power supply. Perform necessary repairs.
15	ECU Failure	Verify correct installation. If code continues, contact Meritor WABCO for assistance.
16	SAE J1708 Failure	Internal failure, contact Meritor WABCO.
17	SAE J2497 Failure	Internal failure, contact Meritor WABCO.
18	Generic I/O Failure	Verify correct electrical installation. Check power supply. Perform necessary repairs.

Trailer Identification

After ensuring the Enhanced Easy-Stop™ trailer ABS has been correctly installed, attach the ABS indicator label included with the ECU/single modulator valve assembly to the trailer. Generally, this will be applied near the ABS trailer indicator lamp. Figure 28. Refer to the vehicle specification sheet for the correct location.

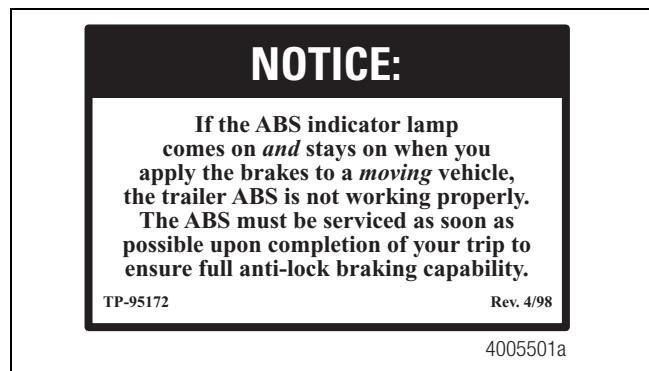

Figure 28

NOTE: If this label is not included with the assembly, let your supervisor know. Labels are available from Meritor WABCO. Ask for part number TP-95172.

For additional assistance, contact Meritor WABCO at 800-535-5560.

Appendix

Enabling the Lift Axle Function (4S/3M Installations)

To enable the lift axle function, you will need a PC with TOOLBOX™ Software, version 4.6 or higher, installed. Refer to the TOOLBOX™ User's manual for complete operating instructions. This manual is posted on our website at meritorwabco.com.

1. Display the **Trailer ABS Main Screen**. Click on **Modify** to display the pull down menu. Figure A-1.
2. Click on **Lift Axle**. The default lift axle screen will appear and display the default lift axle status **Not Active**. Figure A-2.
3. To change the default status and activate the lift axle function, click on **Change**. The **Lift Axle Status** will change to **Active**. Figure A-3.
4. Click on **Close** to close the screen. Exit TOOLBOX™.
5. Remove power from the vehicle; then reapply power.
6. Follow Steps 2 and 3 to display the **Lift Axle Status** screen. Verify the lift axle status display indicates the lift axle function is active, as illustrated in Figure A-3.

If the lift axle function does not indicate active status, verify TOOLBOX™ version 4.6 or higher is installed. If you continue to receive a not active status message, contact the for assistance.

7. Disconnect TOOLBOX™ from the vehicle and proceed with end of line testing as described in this bulletin.

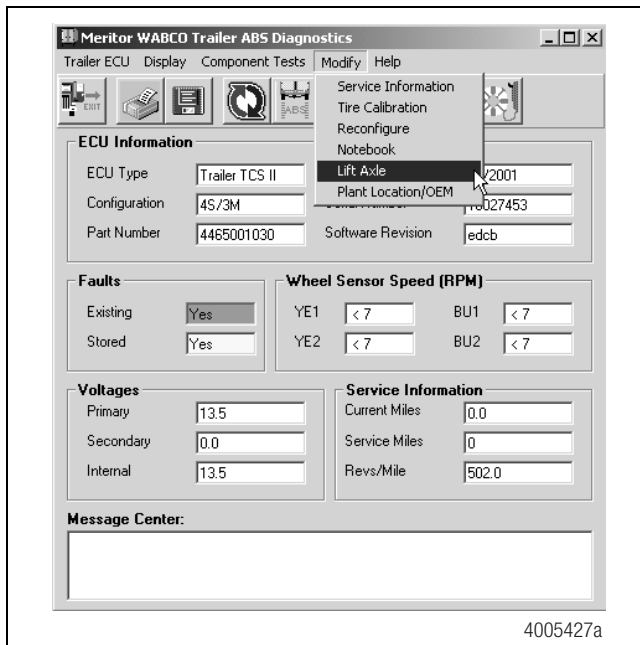

Figure A-1

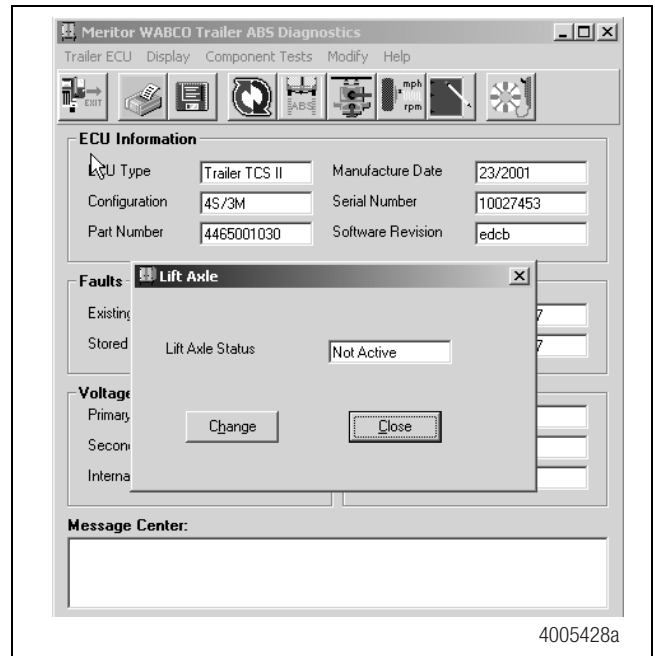

Figure A-2

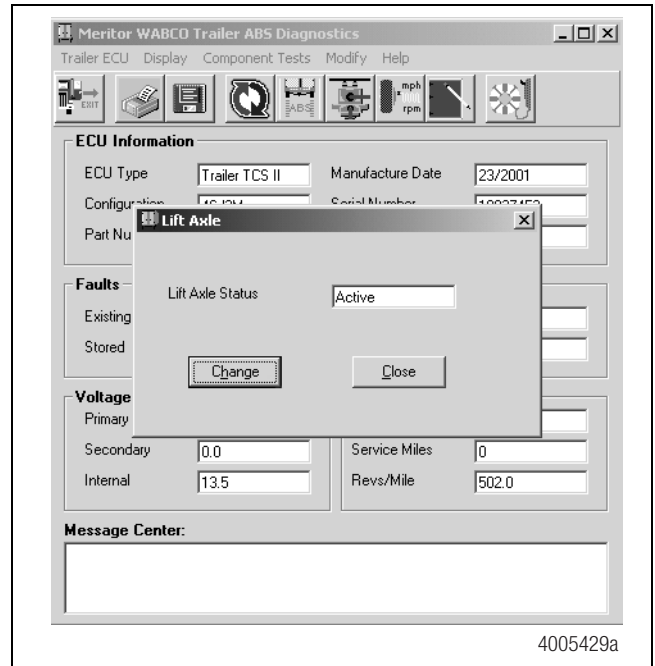

Figure A-3

Installing Sensors on Non-ABS-Prepped Axles

Sensor locations vary due to suspension type. Meritor WABCO recommends placing the sensor on the axle that will provide the most braking performance. Contact your suspension manufacturer for further information.

1. Apply a mineral oil-based grease that contains molydisulfide to the sensor spring clip, the body of the sensor and the bore of the sensor block. The grease must be anti-corrosive and contain adhesive properties that will continuously endure temperatures from -40° to 300°F (-40° to 150°C).
2. Push the spring clip into the sensor holder from the inboard side, until the spring clip tabs are against the sensor holder. Push the sensor into the spring clip as far as possible.
Use Meritor WABCO spring clips to ensure a correct fit.
3. Push the spring clip into the sensor holder from the inboard side until the spring clip tabs are against the sensor holder. Push the sensor into the spring clip as far as possible.
Figure A-4.

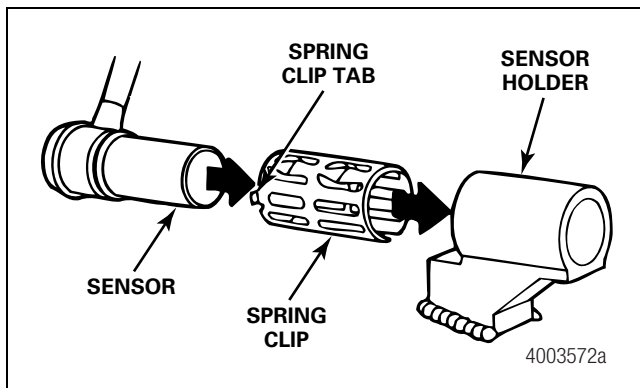

Figure A-4

4. Route the sensor cable toward the brake chamber, over the brake spider or through the pre-stamped hole dedicated for ABS sensors. Route to the back side of the axle. Secure the cable to the axle between the brake spider and the suspension brackets. Continue to route the sensor cable behind the spring seats. Secure the cable to the axle one inch from the molded sensor plug. Figure A-5.

Do not overtighten tie wraps on a cable. Overtightening can damage the cable. Do not tie wrap the molded sensor plug. The sensor extension cable must follow the brake hose to the ECU/valve assembly to allow for axle jounce and rebound.

Brake hose clips with a provision for the sensor extension cable are recommended as opposed to tie wraps. Meritor WABCO does not supply this part.

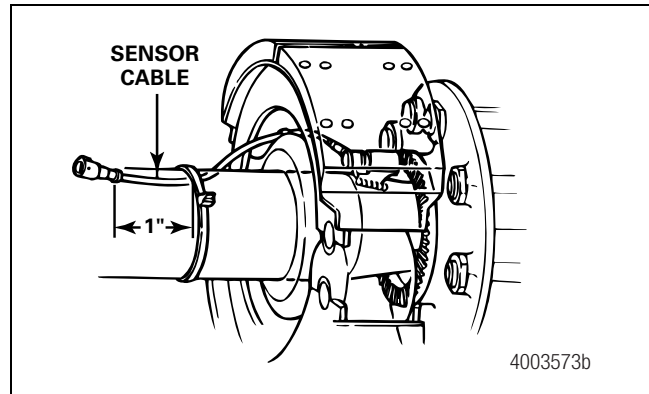

Figure A-5

5. Install the wheel hub carefully so that the tooth wheel pushes against the sensor as the wheel bearings are adjusted. There should be no gap between the sensor and the tooth wheel.
6. Test the sensor output voltage. Use a volt/ohm meter to check the output voltage of the sensors while rotating the wheel at approximately 1/2 revolution per second. Minimum output must be 0.2 volt AC. If minimum output is less than 0.2 volt AC, push the sensor toward the tooth wheel. Recheck the sensor output.

MERITOR WABCO

Meritor WABCO Vehicle Control Systems
2135 West Maple Road
Troy, MI 48084-7121 USA
800-535-5560
meritorwabco.com



Information contained in this publication was in effect at the time the publication was approved for printing and is subject to change without notice or liability. Meritor WABCO reserves the right to revise the information presented or to discontinue the production of parts described at any time.

Copyright 2005
ArvinMeritor, Inc.
All Rights Reserved

Printed in USA

TP-20214
Revised 10-05
(16579/22882)