

SELF-ADJUST CLUTCH INSTALLATION GUIDE



STOP!

READ CAREFULLY BEFORE INSTALLING CLUTCH

This clutch must be installed by a qualified installer. Improper installation or failure to replace or resurface the flywheel, or to replace the pilot bearing, clutch brake or other worn drivetrain components may cause poor clutch release or early failure and void the manufacturer's warranty.

Verify Correct Flywheel Dimensions

Flywheel bore (DIM A) must be a minimum of 10". (See Figure 1)

Figure 1

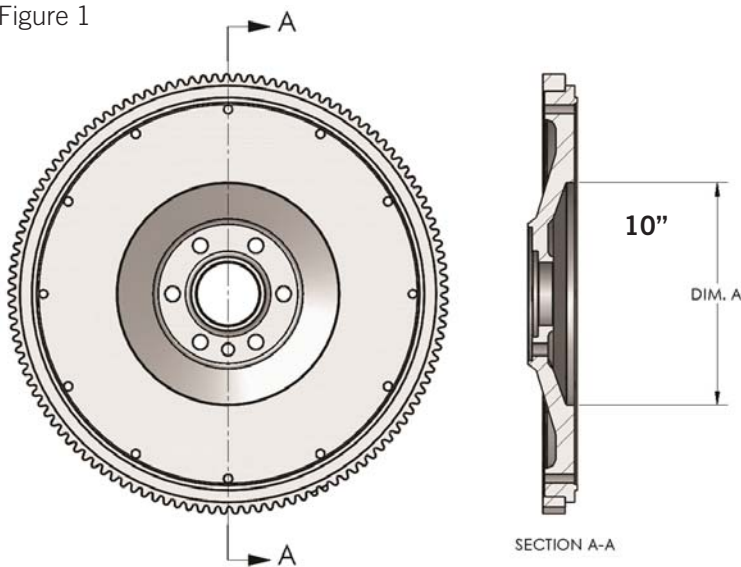

Figure 2

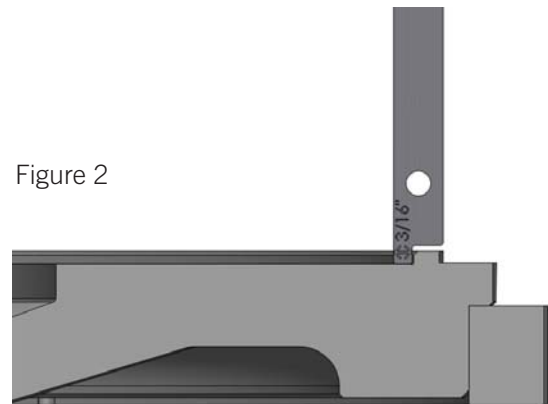
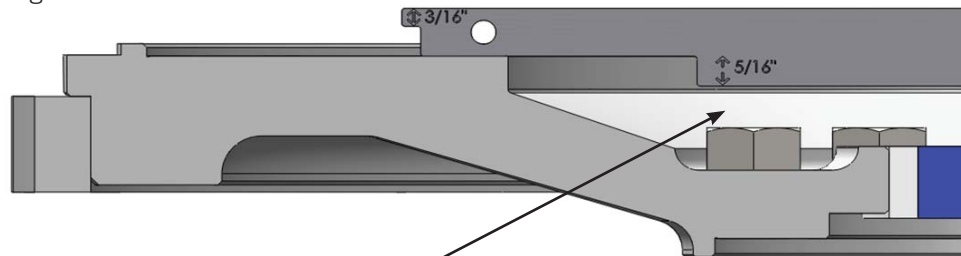

Figure 3



You must have a minimum of 5/16" distance from the friction surface (face) of your flywheel to the top of the bolt head that holds the flywheel to the crankshaft. If it is less than 5/16", you need a NEW flywheel! (See Figure 3)

Flywheel clutch pilot cannot be greater than 3/16" deep. If it is greater than 3/16" the clutch will not bolt tight to flywheel. (See Figure 2)

INSTALLATION

1. Resurface or replace flywheel. Surface must be smooth or premature clutch failure can occur. REMEMBER: Machining the flywheel past the recommended .060" moves the pressure plate away from the transmission. In this event, install a fiber spacer (provided) on the input shaft between the clutch brake and the transmission. The release yoke in the bell housing may not align properly with the pressure plate release bearing housing. Linkage adjustment may be required during clutch set-up. If resurfacing is required, while the flywheel is mounted to the crank shaft, verify correct flywheel dimensions as seen in Figure 2 and Figure 3.
2. Inspect and dial-indicate the mating surface of engine flywheel housing and clutch bell housing for alignment. Check flywheel run out. CAUTION: If misalignment is greater than the recommended limits, this will cause poor clutch release, rapid wear on transmission input shaft and destruction of the clutch disc. Excessive flywheel run out may cause severe vibration in vehicle driveline.
3. A new pilot bearing with a VITON® seal must be used. Before installing pilot bearing into flywheel, check freedom of movement on transmission input shaft.
4. Verify disc fits in flywheel bore (Figure 1). Slide disc the length of the input shaft checking for twist and wear. Insert alignment shaft through bearing housing. Install rear disc (oriented correctly), center plate, and front disc (oriented correctly) on alignment shaft. Move clutch housing towards flywheel making sure cover fits into flywheel pilot.
5. Install the bolts (7/16 x 14unc x 2-1/4) that fasten the clutch housing on the flywheel. Tighten the bolts to the specified torque and the sequence specified by the manufacturer of the vehicle or transmission (Recommended 40-50 ft-lbs). Bolts should be Grade 5 or greater.
6. Remove caging fork from under the release bearing. Remove alignment shaft. Verify bearing distance from cover is 1/2" - 5/8" (See Figure 4). **NOTE: Anytime the clutch is removed from the flywheel, the caging fork needs to be reinstalled. Failure to do so will cause adjusting arm to fall out of retainer stud. See Figure 8 in Reset Procedure.**

Figure 4

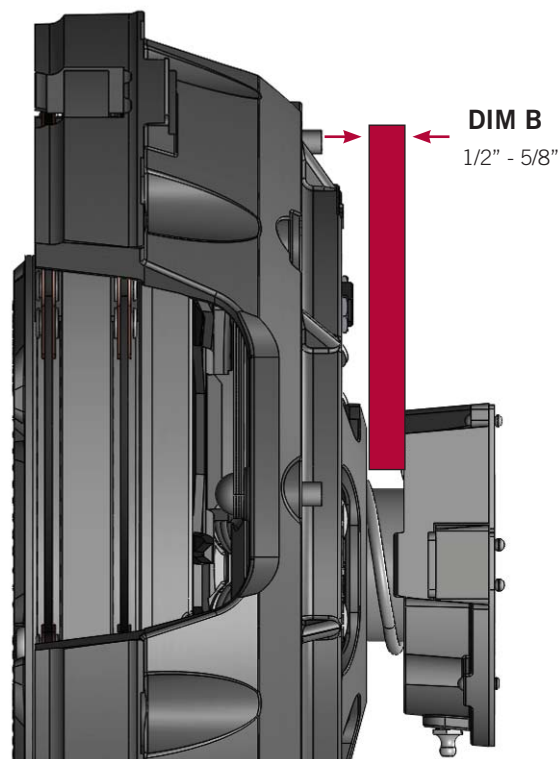

INSTALLATION (cont'd)

7. Reconnect lube hose attachment (For Hydraulic Linkage Systems).
8. Examine transmission input shaft and clutch release system components for wear and replace if necessary. (See Figure 5)
9. Install fiber spacer and replace clutch brake (fiber spacer not needed if oversized clutch brake is used).
10. Be sure to properly lube the following components with NLGI grade 2 or 3 Lithium complex grease: Release Bearing, Yolk Fingers, Cross Shaft Bushings, and Linkage Pivot Points. **Note: Applying enough grease to the release bearing until visible will extend the life of sleeve bushings and input shaft.**

Figure 5

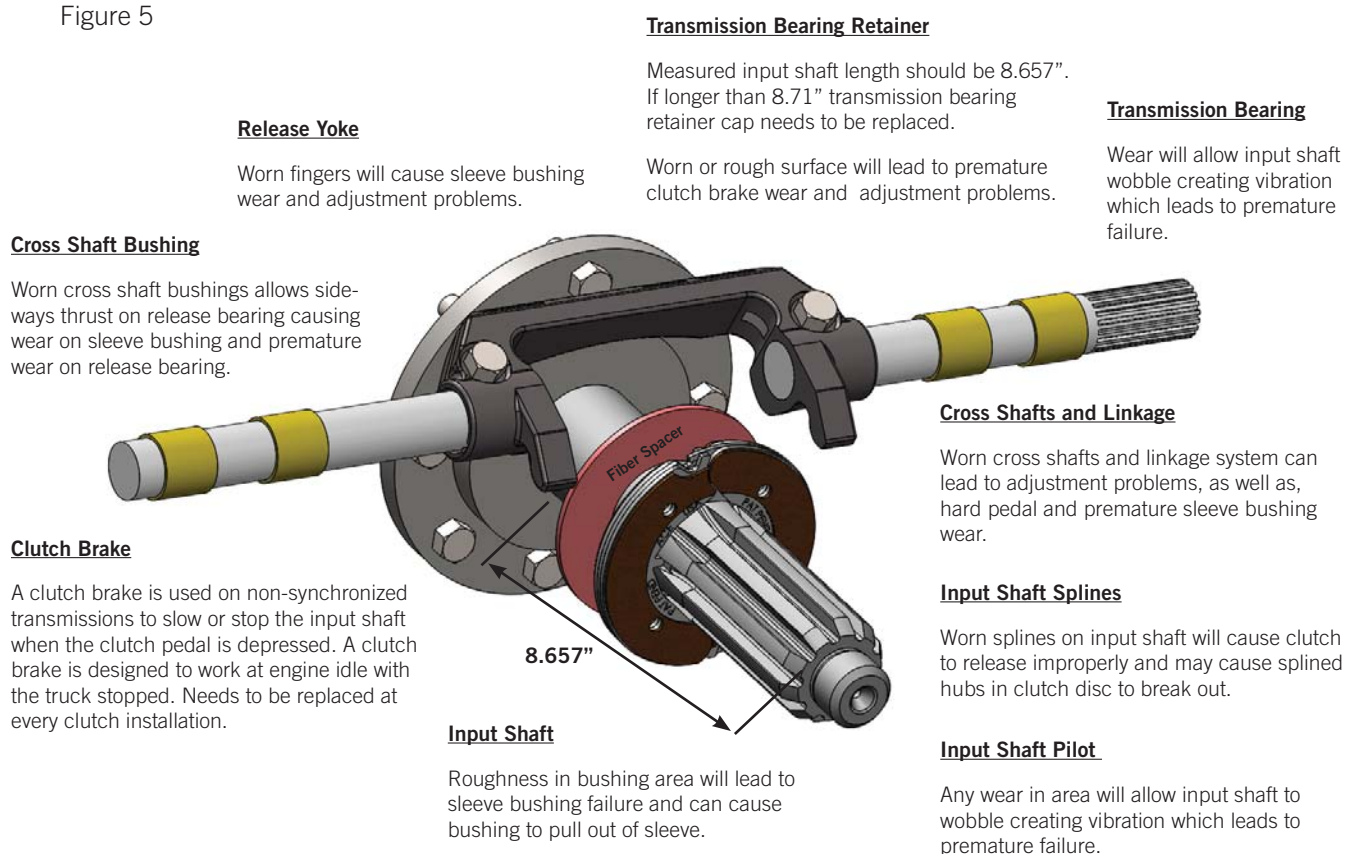

11. Using extreme caution, guide transmission through cover and disc assembly, rotating bell housing shaft so that release yoke fingers are clear of the pads on the release bearing assembly. (**Warning:** Transmission must not hang or be forced into the clutch. This can warp the clutch disc and prevent the clutch from releasing.) **NOTE: Do not add lube to input shaft splines!**
12. Install bell housing bolts and tighten progressively to the torque recommended by the vehicle manufacturer.
13. Install clutch linkage. See "Clutch Set-up Procedure".

CLUTCH SET-UP PROCEDURE

NOTE: Clutches are adjusted at the factory to original equipment specifications and should require very little internal adjustment to achieve proper release and engagement. The clutch must not be adjusted to accommodate thin or worn flywheels, or worn linkage, yoke and/or cross shaft bushings, or to accommodate other drive train deficiencies. Adjustment for such purposes will either cause the clutch to not function properly or will cause early clutch failure and will be apparent on factory inspection of warranty claims, thereby voiding the manufacturer warranty.

STEP #1

After transmission installation, check the clearance between the yoke tips and wear pads on bearing housing for 1/8" clearance. This determines pedal freeplay (Mechanical Linkage Only). (See Figure 6)

Adjust the clutch linkage to increase or decrease the yoke-to-bearing clearance. **NEVER USE THE INTERNAL CLUTCH ADJUSTMENT FOR THIS PURPOSE.**

STEP #2

Check for proper clutch brake and bearing gap of 1/2" to 9/16". If the gap is too small verify DIM B (Figure 4 or Figure 6). If DIM B is correct and a fiber spacer or oversized clutch brake was installed, remove the fiber spacer and/or replace oversized clutch brake with standard thickness clutch brake. **NOTE: If the gap is larger than 9/16" and DIM B is correct then one of the following conditions exists. Fiber spacer/over-sized clutch brake was not installed or input shaft length needs to be re-measured as seen in Figure 4. DO NOT ADJUST THE CLUTCH!**

THIS DIMENSION IS CRITICAL. DO NOT VARY — EITHER OVER OR UNDER THESE DIMENSIONS — UNDER ANY CIRCUMSTANCES.

REMINDER: The bearing must move a minimum of 1/2" or clutch will not release. Eliminate lost motion before checking for 1/2" movement. Lost motion is generally caused by loose or worn linkage, or worn yoke or cross shaft bushings.

STEP #3

Verify the clutch brake squeeze by inserting .010 feeler gauge between bearing and clutch brake, then depressing the pedal to end of stroke. The feeler gauge must be tightly clamped between the bearing and the clutch brake. This verifies the contact of the bearing to the clutch brake.

The clutch brake will be squeezed if the total pedal stroke slightly exceeds the movement required to move the yoke/fork 5/8" to 11/16" (the combined total of the 1/8" clearance between yoke tips and wear pads and the 1/2" - 9/16" brake squeeze gap).

IN THE EVENT THE BRAKE IS NOT BEING SQUEEZED, DO NOT CHANGE THE 1/2" - 9/16" GAP FOR THE CLUTCH BRAKE, OR THE 1/8" CLEARANCE FOR THE BEARING HOUSING — CONSULT THE VEHICLE MANUFACTURER SERVICE MANUAL.

In analyzing the reasons for the brake not being squeezed, other things to check for are:

- A. Worn linkage components or yoke and cross shaft bushings. If necessary, replace those components.
- B. Improper linkage assembly. Verify that linkage is assembled in the correct hole locations.
- C. Pedal stroke. To adjust, raise the upper and/or lower the lower pedal stops.
- D. If the clutch is hydraulically assisted, make sure the slave and master cylinders are functioning properly.

NOTE: MAXIMUM BRAKE SQUEEZE (IN CAB OF TRUCK) SHOULD NOT EXCEED 1" FROM THE END OF PEDAL STROKE. IF IT DOES, IT CAN BE ADJUSTED BY:

- A. Changing pedal stops in cab to reduce total pedal stroke.
- B. Increasing 1/8" yoke-to-bearing setting to lower squeeze. (This will increase free-pedal travel.)

CLUTCH SET-UP PROCEDURE (cont'd)

STEP #4

Installer should carefully verify that there is 1/2" - 5/8" gap between clutch cover and release bearing, 1/8" of free travel between yolk and wear pads (mechanical linkage only), and 1/2" - 9/16" gap between release bearing and clutch brake.

Figure 6

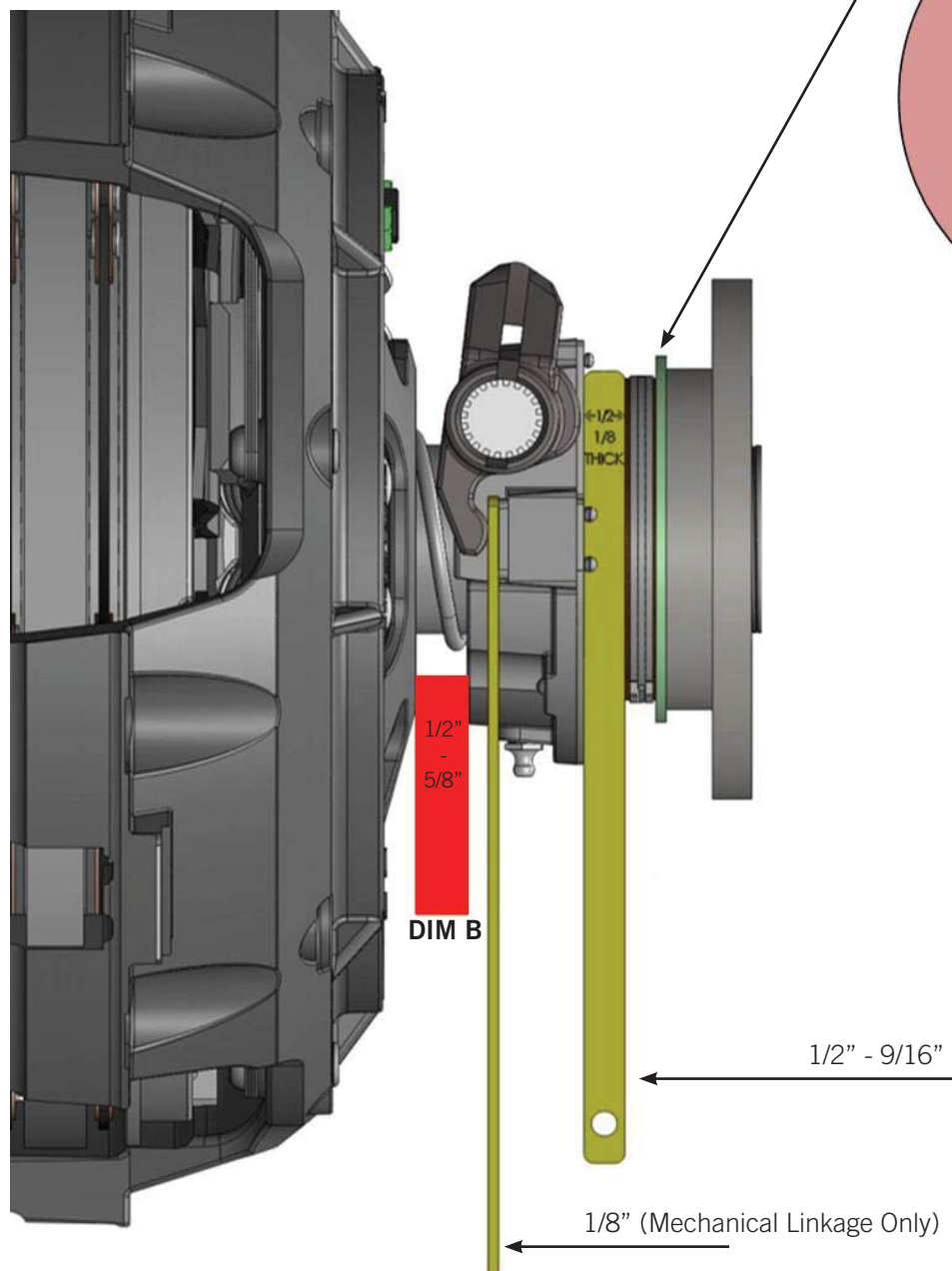

If Fiber Spacer is to be installed after transmission, notch "V" as shown in Schematic 1.

Schematic 1

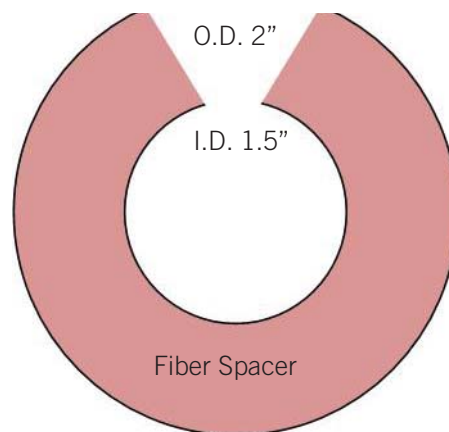

TROUBLESHOOTING AND DIAGNOSTICS

Bearing Position Too Large (Greater than 5/8")

- Disc in backwards
- 5/16" flywheel dimension is too small and disc is hitting crank bolts (See Figure 3)
- Flywheel bore is smaller than 10" (See Figure 1)

Bearing Position Too Small (Less than 1/2")

- Flywheel not resurfaced
- Flywheel Clutch Pilot is less than 3/16" (See Figure 2)
- Forgot to install a disc
- **NOTE: If any of the previous situations occur, verify the adjuster arm is still inserted in stud (see Figure 8)**

Bearing To Brake Gap Is Greater Than 9/16"

- Verify bearing position is in spec between 1/2" - 5/8" (See Figure 4)
- Input shaft measurement is too long/excessive wear on transmission input bearing retainer (See Figure 5)
- Did not use oversized clutch brake or fiber spacer
- Self-adjust mechanism not working — **See Reset Procedure**

Bearing To Brake Gap Is Less Than 1/2"

- Verify bearing position is in spec between 1/2" - 5/8" (See Figure 4)
- Used oversized clutch brake instead of standard clutch brake
- Have fiber spacer and don't need it

Free Travel Is Out Of Spec (Mechanical Linkage Systems Only)

- Verify bearing position is in spec between 1/2" - 5/8" (See Figure 4)
- Verify bearing to brake gap is in spec between 1/2" - 9/16" (See Figure 6)
- Release system linkage components are worn and need to be adjusted or replaced (See Figure 5)

RESET PROCEDURE

If for any reason the clutch needs to be reset or manually adjusted, follow the instructions below.

1. Remove self-adjusting mechanism. (Figure 7)
2. Disengage clutch.
3. Install manual adjust mechanism. (Figure 8)
4. Manually adjust clutch to meet specs in set-up procedure. (See Figure 6)
5. Reinstall self-adjusting mechanism. Ensure adjusting arm is properly seated in the retainer stud as seen in Figure 8.
6. When reinstalling self-adjusting mechanism it may be necessary to manually ratchet the self-adjust mechanism so that the worm gear is seated properly in the adjusting ring teeth.

Figure 7

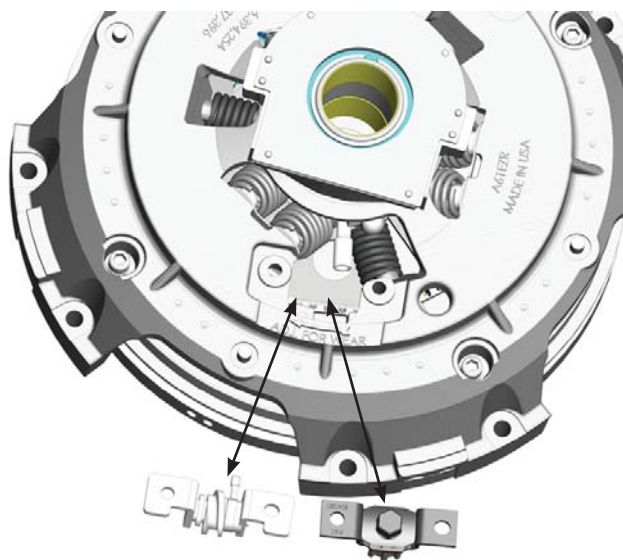
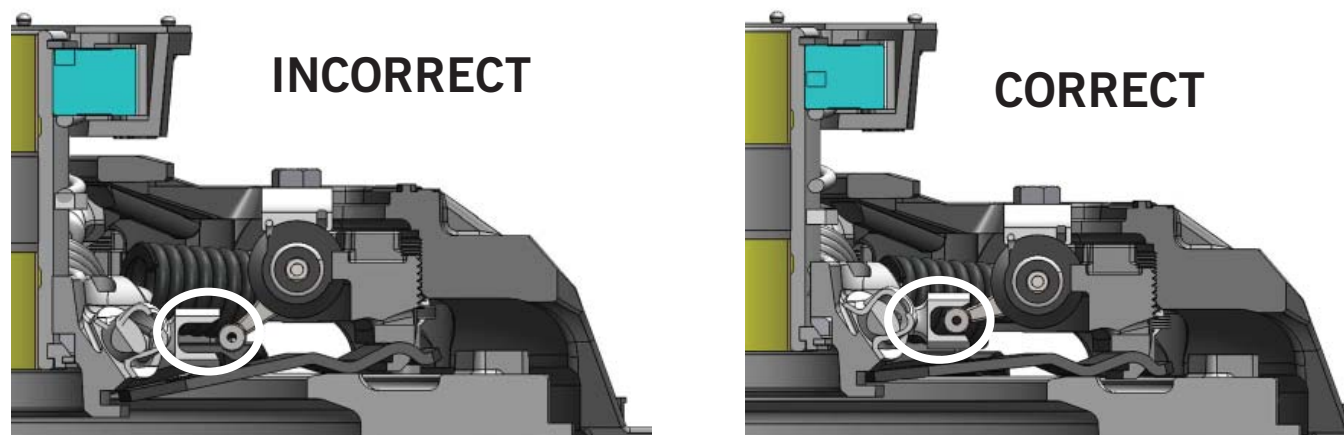

Figure 8





Meritor Heavy Vehicle Systems, LLC
7975 Dixie Highway
Florence, KY 41042

U.S. 888-725-9355
Canada 800-387-3889

MeritorPartsOnline.com

©2016 Meritor, Inc.
Litho in USA
Revised 03-16
TP-1674 (FLOA)