

CLUTCH INSTALLATION AND ADJUSTMENT GUIDE



STOP!

Read Carefully Before Installing Clutch.

This clutch must be installed by a qualified installer. Improper installation or failure to replace or resurface the flywheel, or to replace the pilot bearing, clutch brake or other worn components may cause poor clutch release or early failure and void the manufacturer's warranty.

All 14" clutches use 8 spring disc assemblies and can only be used with a 7" bore flywheel. For 15 1/2" clutch units, measure the flywheel opening to determine the correct clutch is being used for the application.

Flywheel bore size

Must Use

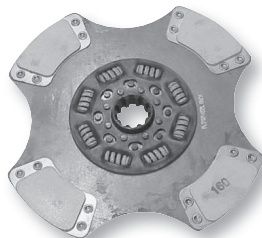
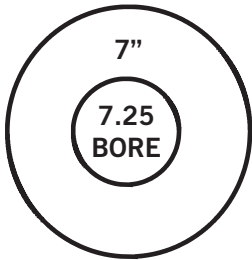

8 Spring Disc

Use one of these models only

Easy Pedal Effort choices
MAF-108391-81

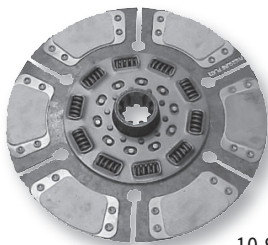
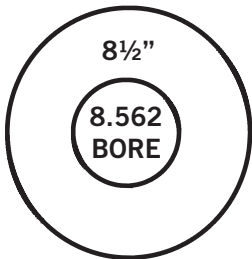

10 Spring Disc



Use one of these models only

Easy Pedal Effort choices
MAF-108391-74
MAF-108391-93
MAF-108391-93H

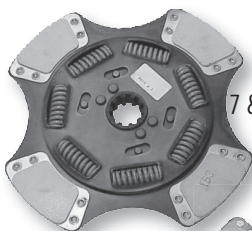
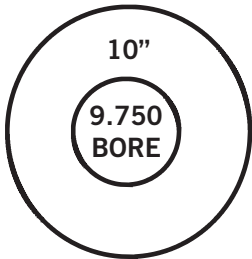

7 & 9 Spring Disc

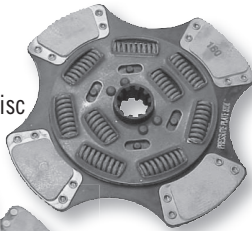

Use one of these models only

Easy Pedal Effort choices
MAF-108925-25
MAF-108925-32H
MAF-108925-82
MAF-108935-51 (Mack)
MAF-108935-91 (Mack)

CHOOSING THE WRONG CLUTCH FOR THE APPLICATION VOIDS THE WARRANTY!
Manually adjusted clutches are not recommended to be installed in vehicles with hydraulic linkage systems.

IS A CLUTCH BRAKE SPACER REQUIRED?

Our Meritor AllFit Clutches are pre-adjusted at the factory. Therefore, no adjustment should be required at the time of installation. However, if the flywheel has been reground and/or the transmission flange is worn, a fiber spacer may be needed in conjunction with the new clutch brake being installed with the clutch.

On vehicles with this type of wear, the common complaint at time of installation is not being able to get the clutch brake to squeeze. The solution could be to use the 1/8" fiber brake washer. Or, the flywheel may need to be replaced.

Before deciding that, however, our recommendation is to install the spacer to see if it solves the issue. One is included with this clutch for that purpose. If the spacer is not needed, discard or save for future installations.

To use the spacer, slide the fiber washer onto the input shaft next to the transmission before the clutch brake itself is put on. Then install the clutch and set the linkage per the usual procedure. **(see schematic 1)**

If the clutch and the transmission are already installed without the spacer and there are release problems, it may be possible to install the spacer without removing the clutch and clutch brake. Cut a "V" shape on the fiber so it can be twisted and slipped onto the input shaft from the side. Be sure to cut the bottom of the "V" smaller than the O.D. of the input shaft so it won't fall off during operation. **(see schematic 2)**

The fiber should now be able to be twisted and fit over the input shaft between the clutch brake and the transmission flange. The clearance between the bearing lid and clutch brake can now be reset at 1/2" to 9/16" with the internal clutch adjuster.

Schematic 1

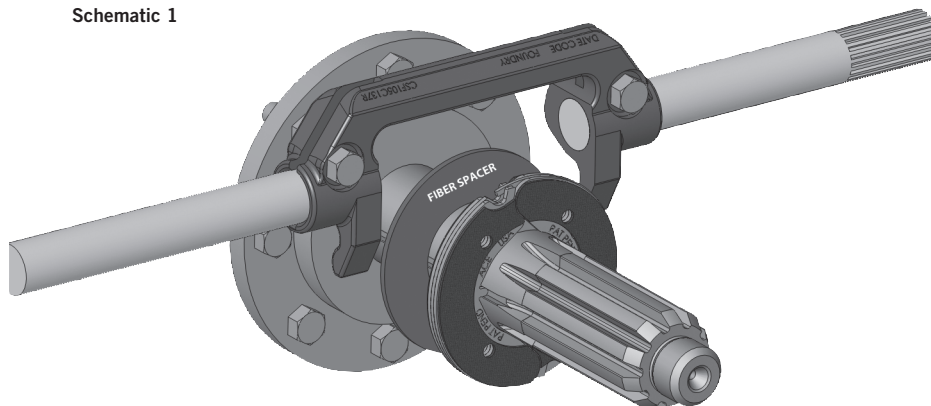

Schematic 2

1-3/4" Fiber Part No. MAF-A153BPB6
2" Fiber Part No. MAF-A148BPB6

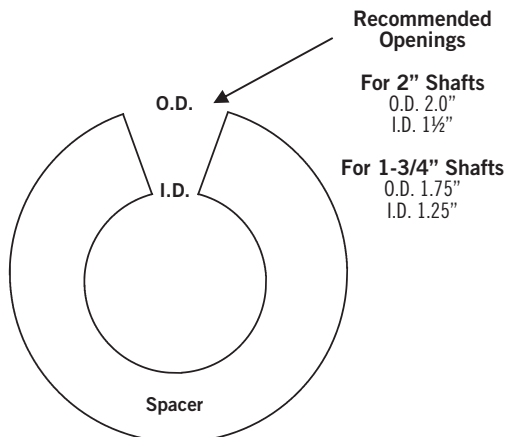



GENERAL INSTALLATION GUIDELINES

For 14" and 15 ½" Two-Plate Clutches

1. (14" & 15 ½") Resurface or replace flywheel. Surface must be smooth or premature clutch failure can occur. Flywheel depth must be 2.937" for 14" pot style flywheels. 15 ½" and 14" medium duty clutches use a flat flywheel. REMEMBER: Machining the flywheel past the recommended .060" moves the pressure plate away from the transmission. In this event, install a fiber spacer (provided) on the pilot shaft between the clutch brake and the transmission. The release yoke in the bell housing may not align properly with the pressure plate release bearing housing. Linkage adjustment may be required.
2. (14" & 15 ½") Inspect and dial-indicate the mating surface of engine flywheel housing and clutch bell housing for alignment and also check flywheel run out. CAUTION: If misalignment is greater than recommended limits, this may cause poor clutch release, rapid wear on transmission pilot shaft and destruction of the clutch disc. Excessive flywheel run out may cause severe vibration in vehicle drive line.
3. (14" & 15 ½") A new pilot bearing should be used. Before installing pilot bearing into flywheel, check freedom of movement on transmission pilot shaft.
4. (14" Pot Flywheel Only) Drive pins in the flywheel should be replaced. Check to ensure drive pin heads are square with the flywheel friction surface. If drive pins are not replaced, assume they have turned. The constant pounding of the center plate may have changed the position of the drive pins in the flywheel. Play it safe — check them all!
5. (14" Pot Flywheel Only) After the drive pins are installed and properly aligned, position the center plate onto the drive pins and check the clearance with a feeler gauge. Clearance should be .006" to .010" and be measured from the same side of the drive pin at each location. The center plate should move up and down freely on the pins.
6. (14" Pot Flywheel Only) Install front clutch disc, center plate and rear disc as marked.
7. (14" Pot Flywheel Only) Insert alignment shaft through both clutch discs making sure it enters the pilot bearing. NOTE: If an old pilot shaft with worn splines is used to align clutch disc, transmission pilot shaft may damage clutch hubs during installation of transmission.
8. (14" Pot Flywheel Only) Position cover assembly onto the pilot shaft and guide towards flywheel mounting surface, making sure the cover fits into the flywheel pilot. Start cap screws.
9. (15 ½" and 14" Medium Duty Only) Insert alignment shaft through bearing housing. Install rear disc, center plate and front disc on alignment shaft. Move clutch housing towards flywheel making sure cover fits into flywheel pilot. Note: 14" medium duty must install adapter ring on flywheel first.
10. (14" & 15 ½" Only) Install the cap screws that fasten the clutch housing on the flywheel. Tighten the cap screws to the specified torque and the sequence specified by the manufacturer of the vehicle or transmission. Cap screws should be Class 5 or greater.
11. (14" & 15 ½") Examine transmission pilot shaft for wear and replace if necessary. Worn splines on pilot shaft will cause clutch to release improperly and may cause splined hubs in clutch disc to break out.
12. (14" & 15 ½") Inspect release bearing yoke and both cross shaft bushings in bell housing and replace if worn. NOTE: For proper clutch release, release bearing housing on cover must "squeeze" clutch brake during clutch disengagement. Worn parts in bell housing may prevent full movement of release bearing during operation of vehicle.
13. (14" & 15 ½") If clutch brake is to be used, place on transmission pilot shaft.
14. (14" & 15 ½") Rotate release bearing housing on cover assembly until flat section is on top. NOTE: Bell housing cross shaft on some vehicles may be below center. This requires the flat section on release bearing to be in down position. (Note position on clutch when being removed.)
15. (14" & 15 ½") Using extreme caution, guide transmission through cover and disc assembly, rotating bell housing shaft so that release yoke fingers are clear of the pads on the release bearing assembly. WARNING: Transmission must not hang or be forced into the clutch. This can warp the clutch disc and prevent the clutch from releasing. Lubricant on input shaft splines can cause slippage or release problems.
16. (14" & 15 ½") Start bell housing cap screws and tighten progressively to the vehicle manufacturer's recommended torque.
17. (14" & 15 ½") Release bearing has been pre-packed with grease from the factory.
18. (14" & 15 ½") Install clutch linkage. See "Clutch Adjustment Procedure".

CLUTCH ADJUSTMENT PROCEDURE

NOTE: Meritor AllFit Clutches are adjusted at the factory to original equipment specifications, and should require very little internal adjustment to achieve proper release and engagement. The clutch must not be adjusted to accommodate thin or worn flywheels, or worn linkage, yoke and/or cross shaft bushings, or to accommodate other deficiencies. Adjustment for such purposes will either cause the clutch to function improperly or will cause early clutch failure, and will be apparent on factory inspection of warranty claims... and therefore will void the manufacturer warranty.

THIS PROCEDURE COVERS BOTH 14" AND 15 1/2" CLUTCHES WHEN A CLUTCH BRAKE IS USED

STEP #1

After clutch installation, check the clearance between the yoke tips and wear pads on bearing housing for 1/8" clearance. This determines pedal free play. (see illustration)

Adjust the clutch **linkage** to increase or decrease the yoke-to-bearing clearance. **NEVER USE THE INTERNAL CLUTCH ADJUSTMENT FOR THIS PURPOSE.**

STEP #2

Check for proper clutch brake and bearing gap of 1/2" to 9/16". If the gap is not within these tolerances add or remove the fiber spacer or the clutch needs adjusting.

If the clutch does need adjusting, remove the lock strap or turn the quick adjuster and set the clearance between the bearing and clutch brake at 1/2" to 9/16". **THIS DIMENSION IS CRITICAL. DO NOT VARY — EITHER OVER OR UNDER THESE DIMENSIONS — UNDER ANY CIRCUMSTANCES.** Over adjusting either way will cause the clutch to slip or not release.

Use the internal adjustment on the clutch to move the bearing. Turn adjuster clockwise to move bearing towards transmission (to decrease clearance) or counter clockwise to move the bearing towards the engine (to increase clearance). If internal adjustment exceeds 4 notches either way the clutch may not release or may slip.

Put tension on the linkage to be sure bearing is stretched and no movement towards the engine is noticed. Measure clutch brake and bearing gap with 1/2" - 9/16" gauge (see illustration). Once the adjustment is set, re-install lock strap. Make sure quick adjuster is in the locked position.

REMINDER: The bearing must move a minimum of 1/2" or clutch will not release. Eliminate lost motion before checking for 1/2" movement. Lost motion is generally caused by loose or worn linkage, or worn yoke or cross shaft bushings.

STEP #3

If internal clutch adjustment was made re-verify the 1/8" clearance between the yoke tips and wear pads on bearing housing shown in Step #1 above (see illustration). If necessary, re-align linkage to obtain proper clearance.

STEP #4

Re-verify the clutch brake squeeze by inserting .010 feeler gauge between bearing and clutch brake, then depressing the pedal to end of stroke. The feeler gauge must be tightly clamped between the bearing and the clutch brake. This verifies the contact of the bearing to the clutch brake.

The clutch brake will be squeezed if the total pedal stroke slightly exceeds the movement required to move the yoke/fork 5/8" to 11/16" (the combined total of the 1/8" clearance between yoke tips and wear pads and the 1/2" - 9/16" brake squeeze gap).

IN THE EVENT THE BRAKE IS NOT BEING SQUEEZED, DO NOT CHANGE THE 1/2" - 9/16" GAP FOR THE CLUTCH BRAKE, OR THE 1/8" CLEARANCE FOR THE BEARING HOUSING. CONSULT THE VEHICLE MANUFACTURER SERVICE MANUAL.

In analyzing the reasons for the brake not being squeezed, other things to check for are:

- A. Worn linkage components or yoke and cross shaft bushings. If necessary, replace those components.
- B. Improper linkage assembly. Verify that linkage is assembled in the correct hole locations.
- C. Pedal stroke. To adjust, raise the upper and/or lower the lower pedal stops.

NOTE: MAXIMUM BRAKE SQUEEZE (IN CAB OF TRUCK) SHOULD NOT EXCEED 1" FROM THE END OF PEDAL STROKE. IF IT DOES, IT CAN BE ADJUSTED BY:

- A. Changing pedal stops in cab to reduce total pedal stroke.
- B. Increasing 1/8" yoke-to-bearing setting to lower squeeze. (this will increase free-pedal travel)



CLUTCH ADJUSTMENT PROCEDURE (cont'd)

STEP #5

Once the external parts are in tune with the clutch, record the measured amount of free-pedal movement in the vehicle log. This is the normal (standard) pedal free travel for this vehicle. If future adjustments are required, clutch should be adjusted back to this standard.

Example: If pedal free travel standard is 2", the clutch may need adjustment when wear has reduced pedal free travel to approximately 1".

INSTALLER SHOULD CAREFULLY CHECK TO VERIFY THERE IS 1/8" OF FREE TRAVEL BETWEEN THE YOKE AND THE WEAR PADS AND A MINIMUM OF 1/2" TO 9/16" OF SPACE BETWEEN THE BEARING AND THE CLUTCH BRAKE.

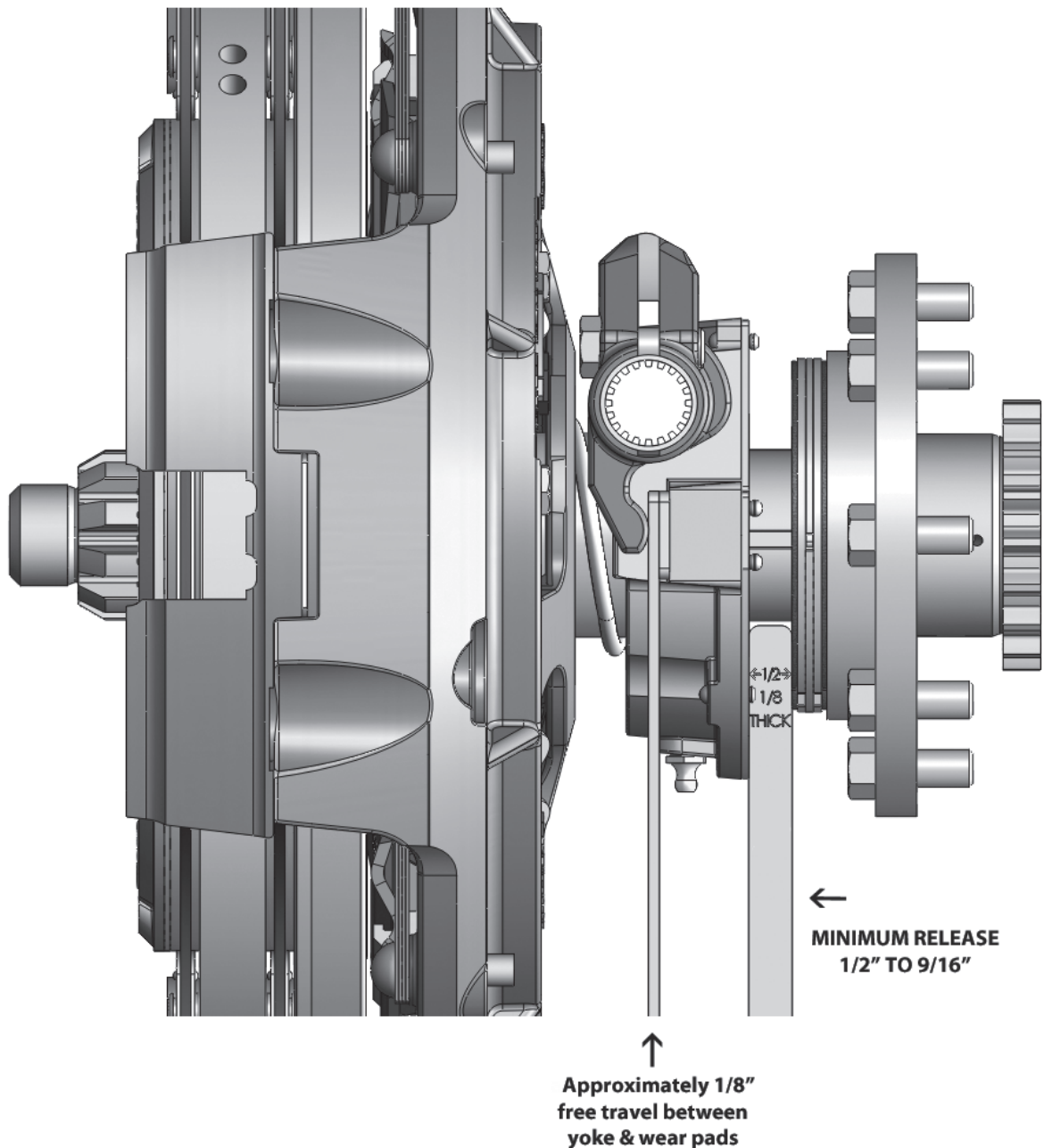

MAINTENANCE TIPS

IT IS IMPORTANT TO NOTE THESE ARE GENERAL GUIDELINES ONLY AND THE INSTALLER SHOULD ALWAYS REFER TO THE VEHICLE MAINTENANCE MANUAL FOR SPECIFIC DETAILS.

1. Only high temperature grease should be used for clutch bearing housing and linkage lubrication. Do not use chassis lubricant for clutch lubrication. Refer to the vehicle maintenance manual for lubricant specifications.
2. Lubricate the clutch release bearing each time the chassis is lubricated.
3. When lubricating the clutch, apply lubricant to each fitting on the clutch housing.
4. Every point in the clutch linkage must be lubricated in addition to the clutch housing.
5. Exercise caution in lubricating the bearing, as any excess lubricant will find its way onto the clutch facing.
6. Adjust the clutch before the pedal clearance has disappeared. Failure to do so will result in slippage and adjustment afterwards may not be effective.
7. If the clutch is hydraulically assisted, make sure the slave and master cylinders are functioning properly.

TECH TIP

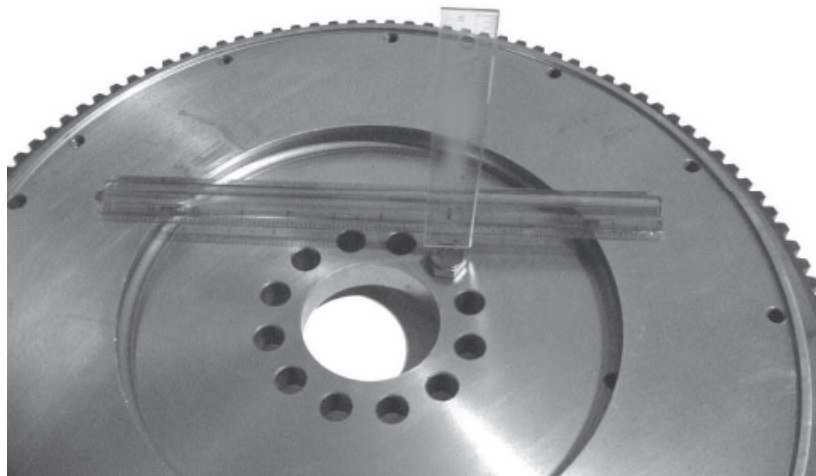

A minimum of 5/16" distance is required from the friction surface (face) of the flywheel to the top of the bolthead that holds the flywheel to the crankshaft. If it is less than 5/16", a NEW flywheel is needed!



Meritor Heavy Vehicle Systems, LLC
7975 Dixie Highway
Florence, Kentucky 41042 USA

888-725-9355 U.S.
800-387-3889 Canada
MeritorPartsOnline.com
meritor.com

©2016 Meritor, Inc.
TP-1628
Issued 01-16 (FLOA)