

MERITOR®
an *ArvinMeritor* brand

Service Parts Instructions

Trailing Arm Bushing Removal and Installation Procedures for All RideStar™ RFS Series Trailer Air Suspension Systems

Kit 11201 (RFS23T)

Kit 11205 (RFS25T)

Hazard Alert Messages

Read and observe all Warning and Caution hazard alert messages in this publication. They provide information that can help prevent serious personal injury, damage to components, or both.

How to Obtain Additional Maintenance, Service and Parts Information

Refer to Maintenance Manual 14F, RideStar™ Trailer Air Suspension Systems, RFS Series, for additional maintenance and service information. A new pivot bolt bushing kit is required to replace the bushings. Refer to Parts Book PB-0226, RideStar™ Trailer Air Suspension Systems, for the correct kit.

To access these publications, visit Literature on Demand at arvinmeritor.com.

How to Obtain Tools, Kits and Supplies

Call ArvinMeritor's Commercial Vehicle Aftermarket at 888-725-9355. Kits may also be obtained by visiting xpresswayplus.com.

Kits Required

Kit 11201 (RFS23T Suspension)

| Quantity | Part Number | Description |
|----------|-------------|--------------------------------|
| 1 | S-21464-M-2 | Capscrew, 7/8"-9 x 8", Grade 8 |
| 1 | M301530 | Hardened Flat Washer, 7/8" ID |
| 1 | M301559 | Locknut, 7/8"-9, Grade C |
| 2 | 21226663 | Wear Washer |
| 1 | 21230476 | Multi-Function Bushing |

Kit 11205 (RFS25T Suspension)

| Quantity | Part Number | Description |
|----------|-------------|--------------------------------|
| 1 | S-21472-M-2 | Capscrew, 7/8"-9 x 9", Grade 8 |
| 1 | M301530 | Hardened Flat Washer, 7/8" ID |
| 1 | M301559 | Locknut, 7/8"-9, Grade C |
| 2 | 21226663 | Wear Washer |
| 1 | 21230539 | Multi-Function Bushing |

Special Tool Required

The bushing replacement procedure requires a special bushing tool, part number A-3256-R-1188. Figure 1.

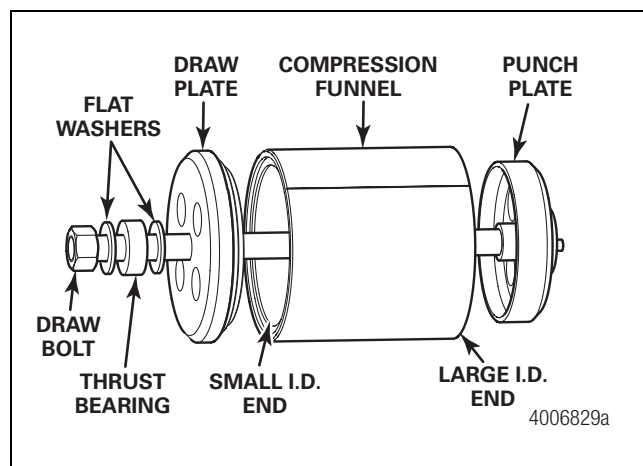

Figure 1

Removal

⚠ WARNING

To prevent serious eye injury, always wear safe eye protection when you perform vehicle maintenance or service.

Park the vehicle on a level surface. Block the wheels to prevent the vehicle from moving. Support the vehicle with safety stands. Do not work under a vehicle supported only by jacks. Jacks can slip and fall over. Serious personal injury and damage to components can result.

To avoid serious personal injury and damage to components, take care when using lifting devices during service and maintenance procedures. Inspect a lifting strap to ensure that it is not damaged. Do not subject the lifting straps to shocks or drop-loading.

Do not remove the height control valve linkage or shock absorber for this procedure. The shock absorber provides vertical support during the bushing installation.

1. Wear safe eye protection.
2. Park the vehicle on a level surface. Block the wheels to prevent the vehicle from moving.
3. Use an appropriate lifting device to raise the trailer frame so that the suspension is above the specified ride height. Refer to Maintenance Manual 14F to determine the correct ride height. Support the rear of the trailer with safety stands.
4. Exhaust all air from the suspension system by unseating the valve at the bottom of the air tank.
5. Support the trailing arm and axle subassembly with safety stands.
6. Remove the locknut and inner concentric alignment collar from the pivot bolt at both hanger assemblies. Figure 2. Carefully remove the pivot bolts and outer alignment collars from both sides.

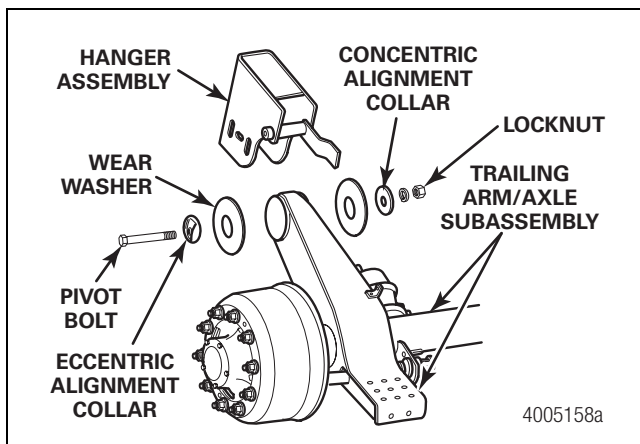

Figure 2

7. Lower the trailing arm and axle subassembly down and out of the hangers. Discard the locknuts, pivot bolts, wear washers and alignment collars.
8. Apply a small amount of lubricant around the radius of the bushing with the bushing still in the tube. Meritor recommends using a mild non-petroleum-base dish soap.
9. Apply a light coat of lubricant to the inside diameter of the compression funnel. Place the smaller end of the compression funnel onto the trailing arm bushing tube. Figure 3.

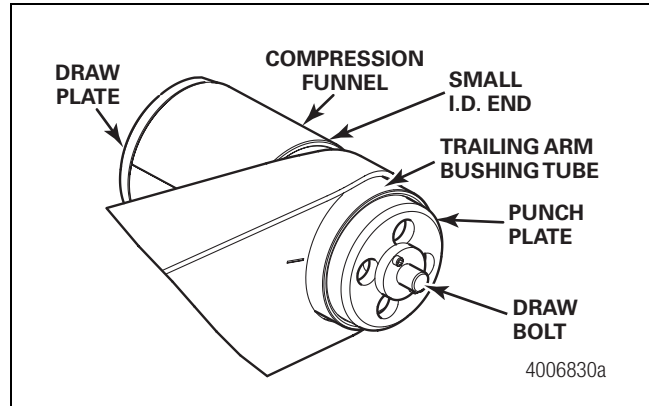

Figure 3

10. Place the draw plate onto the large I.D. end of the compression funnel opposite of the trailing arm bushing tube.
11. Insert the draw bolt, flat washers and thrust bearing through the draw plate and the multi-functional bushing. Figure 3.
12. Thread the punch plate onto the draw bolt until it rests against the bushing to be removed. Figure 3.
13. Snug the draw bolt while ensuring that the compression funnel rests securely against the trailing arm bushing tube. Figure 4. The thrust bearing must be free to turn at all times. Meritor recommends lubricating the draw bolt threads and between the thrust bearing and flat washers with bearing grease such as Shell Darina Grease 1 or equivalent, before each bushing replacement.

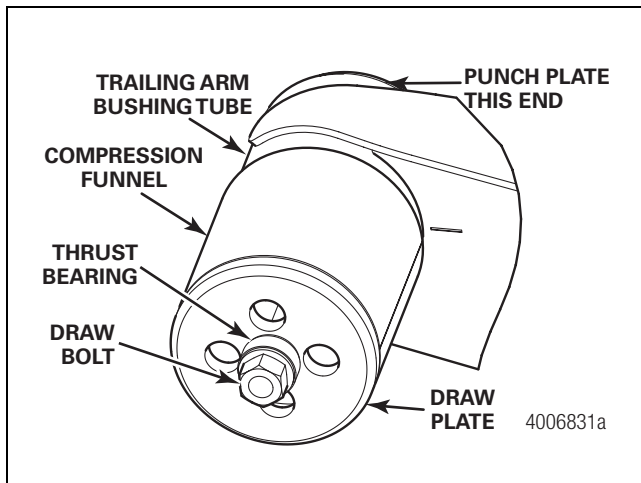

Figure 4

⚠ CAUTION

Tighten the draw bolt until the bushing contacts the draw plate. Do not overtighten the draw bolt. Overtightening can cause damage to the threads or punch plate.

14. Turn the draw bolt CLOCKWISE using a 1/2-inch impact wrench at a reduced and steady speed. Continue turning the draw bolt until the bushing is pulled into the compression funnel against the draw plate.
 - **If the bolt stops turning or extreme resistance is present:** Reverse the impact wrench and loosen the tool assembly. Inspect all components of the tool for damage. Reset the draw plate ensuring that the compression funnel is correctly seated against the trailing arm bushing tube. Try to turn the draw bolt again.
15. After the bushing is removed from the trailing arm bushing tube, reverse the impact wrench and disassemble the tool.
16. Remove the bushing from the compression funnel. Do not dent or damage the compression funnel during this process. Damage to the funnel will affect tool operation.

Installation

1. Inspect the inside of the trailing arm bushing tube for rust, rubber and any other buildup. Clean the tube before installing a new bushing.
2. Remove all burrs from the bushing tube edges. The bushing tube must be cool before installing a new bushing.
3. Use the Meritor lubricant supplied with the bushing kit to lightly lubricate the inside of the trailing arm bushing tube and compression funnel, and the outside diameter of the new multi-functional bushing.

4. Insert the multi-functional bushing into the large I.D. end of the compression funnel. Verify that the bushing mark is aligned with the compression funnel indicator line. Use the bushing indicator mark adjacent to the molded metal insert. Figure 5.

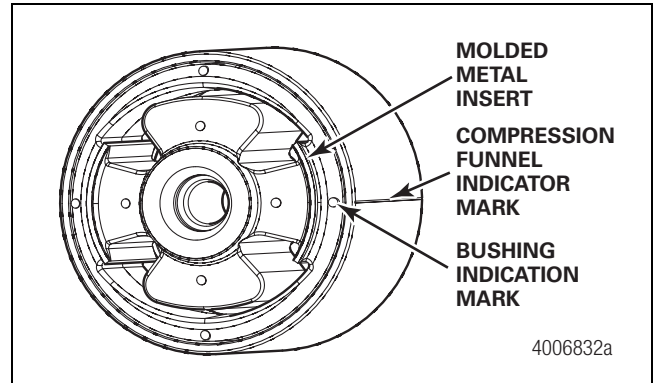

Figure 5

5. Place the draw plate onto the inside surface of the trailing arm bushing tube.
6. Insert the draw bolt, flat washers and thrust bearing through the draw plate and trailing arm bushing tube.
7. Place the small end of the compression funnel with the bushing over the draw bolt and onto the trailing arm bushing tube. Align the indicator mark on the compression funnel with the existing mark on the trailing arm. Figure 6.

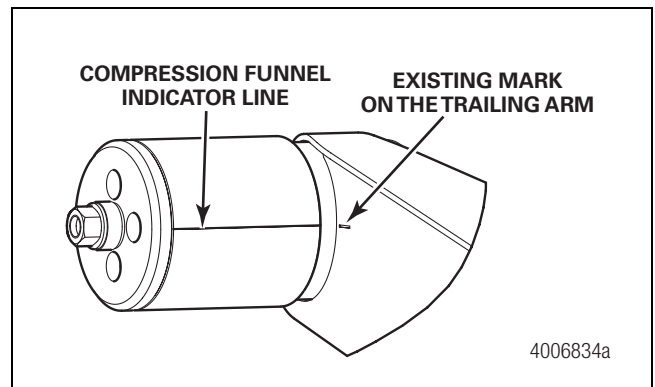

Figure 6

8. Thread the punch plate onto the draw bolt until it rests against the bushing inside the compression funnel. Figure 7.

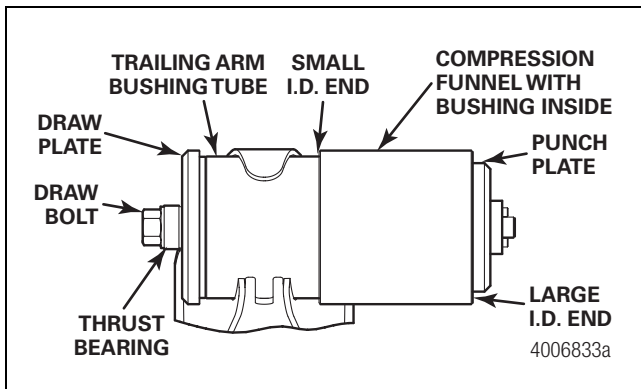

Figure 7

9. Verify that the indicator line on the compression funnel lines up with the existing mark on the trailing arm. Figure 6.
10. Snug the draw bolt while ensuring that the compression funnel and draw plate rest securely against the trailing arm bushing tube. The thrust bearing must be free to turn at all times.

⚠ WARNING

Support the compression funnel as it disengages from the bushing tube. Do not allow it to fall to the floor to prevent serious personal injury and damage to components.

⚠ CAUTION

Rotate the draw bolt only to the point at which it stops turning. Do not overtighten the bolt. Damage to components can result.

11. Turn the draw bolt CLOCKWISE using a 1/2-inch impact wrench at a reduced and steady speed to draw the bushing into the trailing arm bushing tube. Figure 7.
12. Support the compression funnel as it disengages from the bushing tube so it does not fall. The compression funnel will fall away before the bushing is completely seated inside the bushing tube.
13. Continue rotating the draw bolt until the bolt stops turning. Do not overtighten the bolt.
 - **If the bolt stops turning or extreme resistance is present:** Reverse the impact wrench and loosen the tool assembly. Inspect all components of the tool kit for damage. Reset the draw plate ensuring that the compression funnel is correctly seated against the trailing arm bushing tube. Try to tighten the bolt again.

14. Verify that the bushing indicator mark is aligned with the existing mark on the trailing arm. Figure 8.

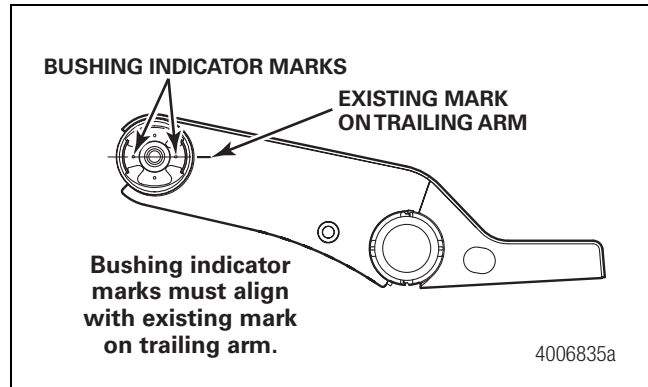

Figure 8

15. Verify that the bushing is centered in the trailing arm bushing tube from side-to-side.
16. Install the wear washers from the pivot bolt kit onto each side of the multi-functional bushing inner metal. Ensure that the wear washers do not get pinched between the ends of the bushing inner metals and the hangers.
17. Raise the trailing arm and axle subassembly up and back into the hangers.
18. Install the pivot bolts and locknuts. Do not tighten the locknuts at this time.
19. Reseat the valve at the bottom of the air tank and apply supply air to the trailer.
20. Remove the safety stands at the rear of the trailer and slowly lower the trailer back down onto the suspension.
21. Verify that the suspension ride height is correct. If adjustment is necessary, refer to Maintenance Manual 14F for ride height adjustment procedures.
22. Realign the axle. Refer to Maintenance Manual 14F for alignment procedures.
23. Tighten the locknuts to 470-570 lb-ft (637-773 N•m) oiled or 600-750 lb-ft (814-1017 N•m) dry. **ⓘ**

ArvinMeritor™

Meritor Heavy Vehicle Systems, LLC
2135 West Maple Road
Troy, MI 48084 USA
800-535-5560
arvinmeritor.com

Information contained in this publication was in effect at the time the publication was approved for printing and is subject to change without notice or liability. Meritor Heavy Vehicle Systems, LLC, reserves the right to revise the information presented or to discontinue the production of parts described at any time.

Copyright 2008
ArvinMeritor, Inc.
All Rights Reserved

Printed in USA

TP-0807
Issued 01-08
(16579/22882)