

**MERITOR®**  
an **ArvinMeritor** brand

## Technical Bulletin

# Carrier-to-Housing Joint Tapered Dowel Repair Procedure

All Meritor RP-164 and RD-164 Series Forward and RR-164 Series Rear Axle Carriers

## How to Obtain Additional Maintenance and Service Information

Refer to Maintenance Manual 5L, Single-Reduction Forward and Rear Differential Carriers on Tandem and Tridem Axles; and Maintenance Manual 5A, Single-Reduction Differential Carriers. To obtain these publications, call ArvinMeritor's Customer Service Center at 800-535-5560, or visit Literature on Demand at meritorhvs.com.

## How to Obtain Kits

This procedure requires you to obtain KIT 164, KIT 4285 and KIT 4289. Call ArvinMeritor's Commercial Vehicle Aftermarket at Florence, Kentucky (888-725-9355); or Brampton, Ontario, Canada (905-454-7070).

### KIT 164 (Reamer Tool)

Contents	Description	Quantity
Bit 164 Reamer	To replace the reamer only	1
Jig 164 Bit Tool	To replace the jig only	1

### KIT 4285 (For Forward Carriers)

Contents	Description	Quantity
10 X 1594	Capscrew	5
10 X 1595	Bolt	4
10 X 1599	Bolt	3
1229 W 1557	Hardened Washer	15
1246 V 1166	Dowel	6
Technical Bulletin TP-0441	Instructions	1
N-110P-1	Nut	3
2297-A-7021	Loctite® 5699	1

### KIT 4289 (For Rear Carriers)

Contents	Description	Quantity
10 X 1594	Capscrew	5
10 X 1595	Capscrew	3
10 X 1600	Capscrew	4
1229 W 1557	Hardened Washer	12
1246 V 1166	Dowel	4
Technical Bulletin TP-0441	Instructions	1
2297-A-7021	Loctite® 5699	1

## Repair Procedure

### WARNING

To prevent serious eye injury, always wear safe eye protection when you perform vehicle maintenance or service.

**Park the vehicle on a level surface. Block the wheels to prevent the vehicle from moving. Support the vehicle with safety stands. Do not work under a vehicle supported only by jacks. Jacks can slip or fall over. Serious personal injury and damage to components can result.**

1. Remove the carrier from the housing. Refer to Maintenance Manual 5L.
2. Verify that the tapered reamer bit pilot fits in the carrier flange holes. Figure 1 and Figure 2.
  - **If the pilot does not fit:** Use the reamer bit to drill the carrier flange holes.

### FORWARD CARRIER TAPERED DOWEL LOCATIONS

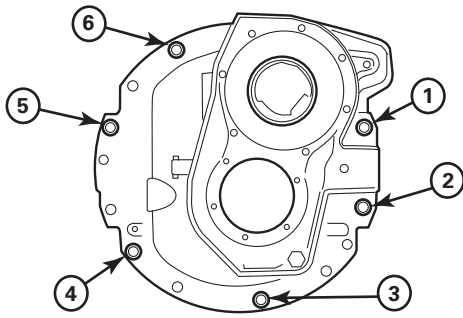

4004488a

Figure 1

### REAR CARRIER TAPERED DOWEL LOCATIONS TOP

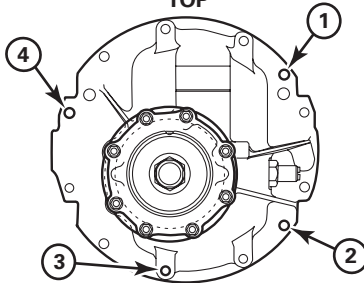

4005373b

Figure 2

3. Slide the tapered reamer bit into the jig hole. Attach the jig to the adjacent bolt hole. Figure 3 and Figure 4.
  - If the carrier is equipped with a driver-controlled differential lock (DCDL): You must use a 5/8-inch nut to secure the jig to the carrier housing. Figure 5 and Figure 6.

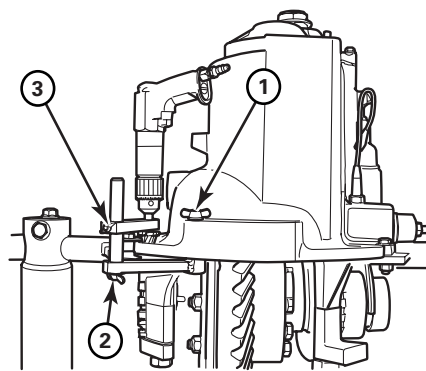

4004491a

Figure 3

4. Align the tapered reamer bit pilot in the carrier hole. The bit must fit at a 90 degree angle to the carrier flange surface. Figure 4.

5. Tighten the jig bolts in the order shown. Figure 3. The tapered reamer bit pilot must be all the way in the carrier hole and positioned 90 degrees to the carrier flange.
6. Lubricate the carrier hole and the reamer bit shaft that contacts the jig.

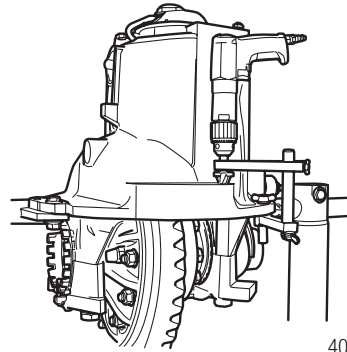

4004522a

Figure 4

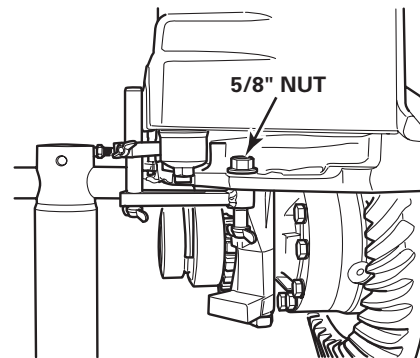

4004489a

Figure 5

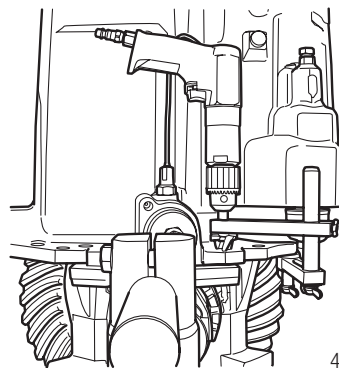

4004490a

Figure 6

7. Drill slowly until the reamer bit stop reaches the carrier flange surface.

8. Clean any debris from the drilled hole. Insert the tapered dowel into the hole. The dowel must fit tight in the hole and must not move back and forth or side to side.
  - **If you can move the tapered dowel back and forth or side to side in the hole:** The tapered dowel does not fit tight enough. Remove the dowel. Use the drill bit and jig to drill the hole slightly deeper. Clean any debris from the hole. Insert the tapered dowel.
9. Repeat Steps 3-8 for the remaining holes.
10. Remove all debris from inside the housing.

### **CAUTION**

When you clean the silicone from the mounting surfaces, use a non-abrasive disk on the rotary tool and keep it perpendicular to the housing and carrier face. Take care to ensure you do not remove the base housing flange material. Use care especially at the 6 o'clock position where most leaks occur and where there is the least amount of housing and carrier surface area. A leak can result in damage to components.

11. Use a rotary tool with a scour pad to clean all silicone residue from the housing and carrier faces. Figure 7. Surfaces must be clean, dry and free of foreign matter. The surfaces must not be oily to the touch.
12. Remove metal filings from the magnets inside the housing.

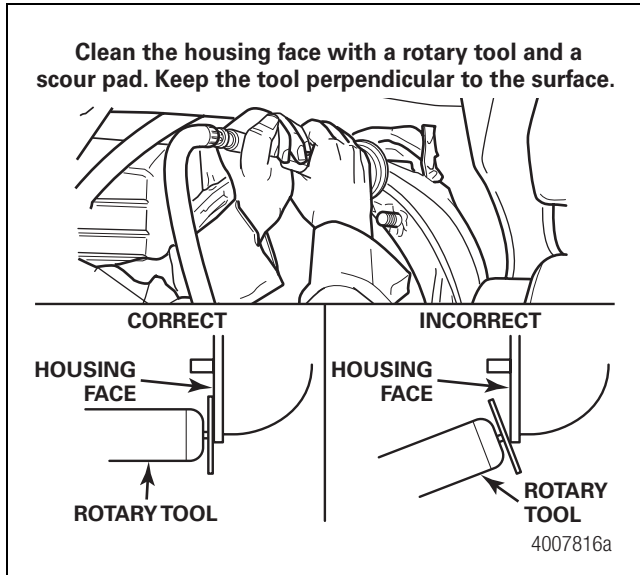

**Figure 7**

### **WARNING**

Solvent cleaners can be flammable, poisonous and cause burns. Examples of solvent cleaners are carbon tetrachloride, and emulsion-type and petroleum-base cleaners. Read the manufacturer's instructions before using a solvent cleaner, then carefully follow the instructions. Also follow the procedures below.

- Wear safe eye protection.
- Wear clothing that protects your skin.
- Work in a well-ventilated area.
- Do not use gasoline or solvents that contain gasoline. Gasoline can explode.
- You must use hot solution tanks or alkaline solutions correctly. Read the manufacturer's instructions before using hot solution tanks and alkaline solutions. Then carefully follow the instructions.

13. Use solvent to clean the inside of the housing.
14. Use Loctite® ODC Free cleaner or brake cleaner to clean the housing and carrier faces.
15. Dry the housing and carrier faces.
16. Use a tap to clean the internal threads in the housing.

### **WARNING**

When you apply some silicone gasket materials, a small amount of acid vapor is present. To prevent serious personal injury, ensure that the work area is well-ventilated. Read the manufacturer's instructions before using a silicone gasket material, then carefully follow the instructions. If a silicone gasket material gets into your eyes, follow the manufacturer's emergency procedures. Have your eyes checked by a physician as soon as possible.

### **CAUTION**

Only apply Loctite® 5699 silicone gasket material, Meritor part number 2297-A-7021, to the housing face. Do not apply ThreeBond 1216E silicone products. Damage to components can result.

17. Apply a 0.25-inch (6 mm) bead of Loctite® 5699 silicone gasket material, Meritor part number 2297-A-7021, to the housing face. Do not apply ThreeBond 1216E silicone products. Damage to components can result. Only use the specified amount of gasket material; otherwise, it can break off, plug lubrication passages and damage components. Figure 8.

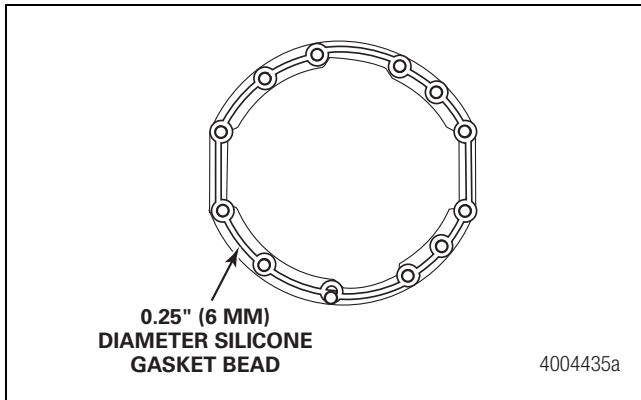



**Figure 8**

18. Install the carrier into the housing. Refer to Maintenance Manual 5L.

**CAUTION**

New capscrew kits have blue Dri-Loc<sup>®</sup> STS threadlocker, an equivalent to Loctite<sup>®</sup> 242 threadlocker, applied to the capscrews. Do not remove the blue Dri-Loc<sup>®</sup> STS threadlocker from the capscrews. Damage to components can result.

19. Install new capscrews with blue Dri-Loc<sup>®</sup> STS threadlocker. Tighten the capscrews and stud nuts in the following order.
- A. Install the capscrews to secure the tapered dowels. On forward axle carriers, use four 2-inch capscrews and two 3.5-inch capscrews. On rear axle carriers, use three 2-inch capscrews and one 4.25-inch capscrew. Tighten the capscrews in a crisscross pattern to 80-100 lb-ft (109-136 N•m). 
  - B. Install the remaining capscrews. Tighten the capscrews in a crisscross pattern to 80-100 lb-ft (109-136 N•m). 
  - C. Tighten all the capscrews in a crisscross pattern to 225 lb-ft (306 N•m). 

**WARNING**

Take care when you use Loctite<sup>®</sup> adhesive to avoid serious personal injury. Read the manufacturer's instructions before using this product. Follow the instructions carefully to prevent irritation to the eyes and skin.

- D. Apply Loctite<sup>®</sup> 242 threadlocker on the stud threads to secure the stud nuts.
  - E. Within five to 10 minutes after applying Loctite<sup>®</sup> 242 threadlocker, tighten the stud nuts to 225 lb-ft (306 N•m). If you wait longer than 10 minutes to tighten the stud nuts, the threadlocker can set, which can affect clamp load. Damage to components can result. 
20. Wait a minimum of 60 minutes before filling the assembly with lubricant.

**ArvinMeritor**<sup>™</sup>

Meritor Heavy Vehicle Systems, LLC  
2135 West Maple Road  
Troy, MI 48084 USA  
800-535-5560  
arvinmeritor.com

Information contained in this publication was in effect at the time the publication was approved for printing and is subject to change without notice or liability. Meritor Heavy Vehicle Systems, LLC, reserves the right to revise the information presented or to discontinue the production of parts described at any time.

Copyright 2009  
ArvinMeritor, Inc.  
All Rights Reserved

Printed in USA

TP-0441  
Revised 05-09  
(16579)