

THE NEXT LEVEL IN FRONT STEER AXLE

MFS+™ FRONT STEER AXLE

The Cummins-Meritor MFS+ features the patented, market-leading technology of MFS™ Series front axles. The system saves weight while improved performance and packaging reduces service time.

PERFORMANCE ADVANTAGES

- Optimized beam design provides a stronger and lighter-weight package
- Integrated torque plate and tie rod arms reduce weight and increase payload
- Reduced assembly time and maintenance costs
- Compatible with Cummins-Meritor EX+™ air disc brakes and Q+™ drum brakes



Meritor

**FOR
A WORLD
THAT'S
ALWAYS ON™**

MFS+ FRONT STEER AXLE

For more than 110 years, Cummins-Meritor has provided innovative solutions for the trucking industry. The lighter-weight axle features the same durability that you expect from MFS Series axles, fully optimized to improve performance and reliability.

**REDUCED
LIFECYCLE
COSTS**

FEATURES

- Same durability and reliability that MFS front axles are known for in the industry
- Integrated torque plate, knuckle and tie rod arms reduce weight and optimize performance
- Available in standard and wide track with weight ratings of 12K and 13K

**85LBS
WEIGHT
REDUCTION***

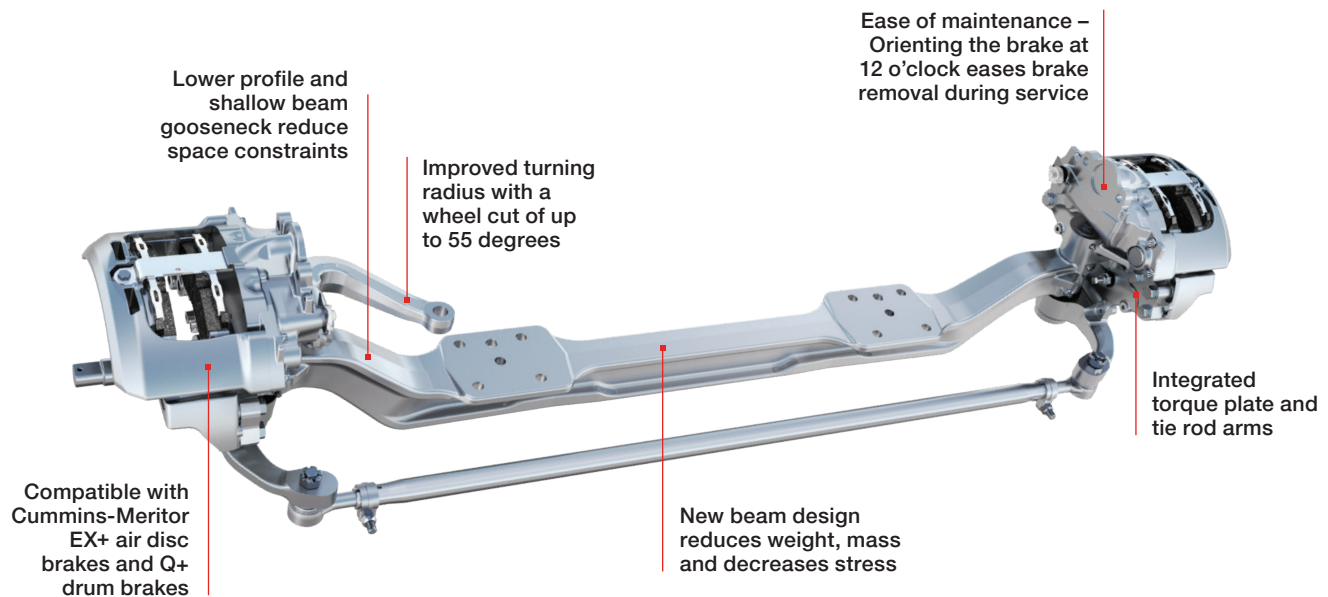

WARRANTY COVERAGE

Axle warranty is 5 years/750,000 miles, with parts and labor included. Every claim is fully supported by OnTrac™. For details, call **866-668-7221 (OnTrac1)**.

UNMATCHED CUSTOMER SUPPORT

Every Cummins-Meritor MFS+ front steer axle is backed by unsurpassed service and support, with DriveForce™ – Cummins-Meritor's North American sales and service organization – and the OnTrac technical support center available to assist customers with solutions before, during and after the sale. For more information, call **866-668-7221 (OnTrac1)** or visit **cummins.com**.



Cummins Inc.
Box 3005
Columbus, IN 47202-3005
U.S.A.

cummins.com

SP-11111
Bulletin 6448334 Produced in U.S.A. Rev. 6/24
©2024 Meritor, Inc.

*Weight savings may vary subject to configuration of brakes and track.