

# MERITOR® MPG SERIES™ SYSTEM AND COMPONENTS

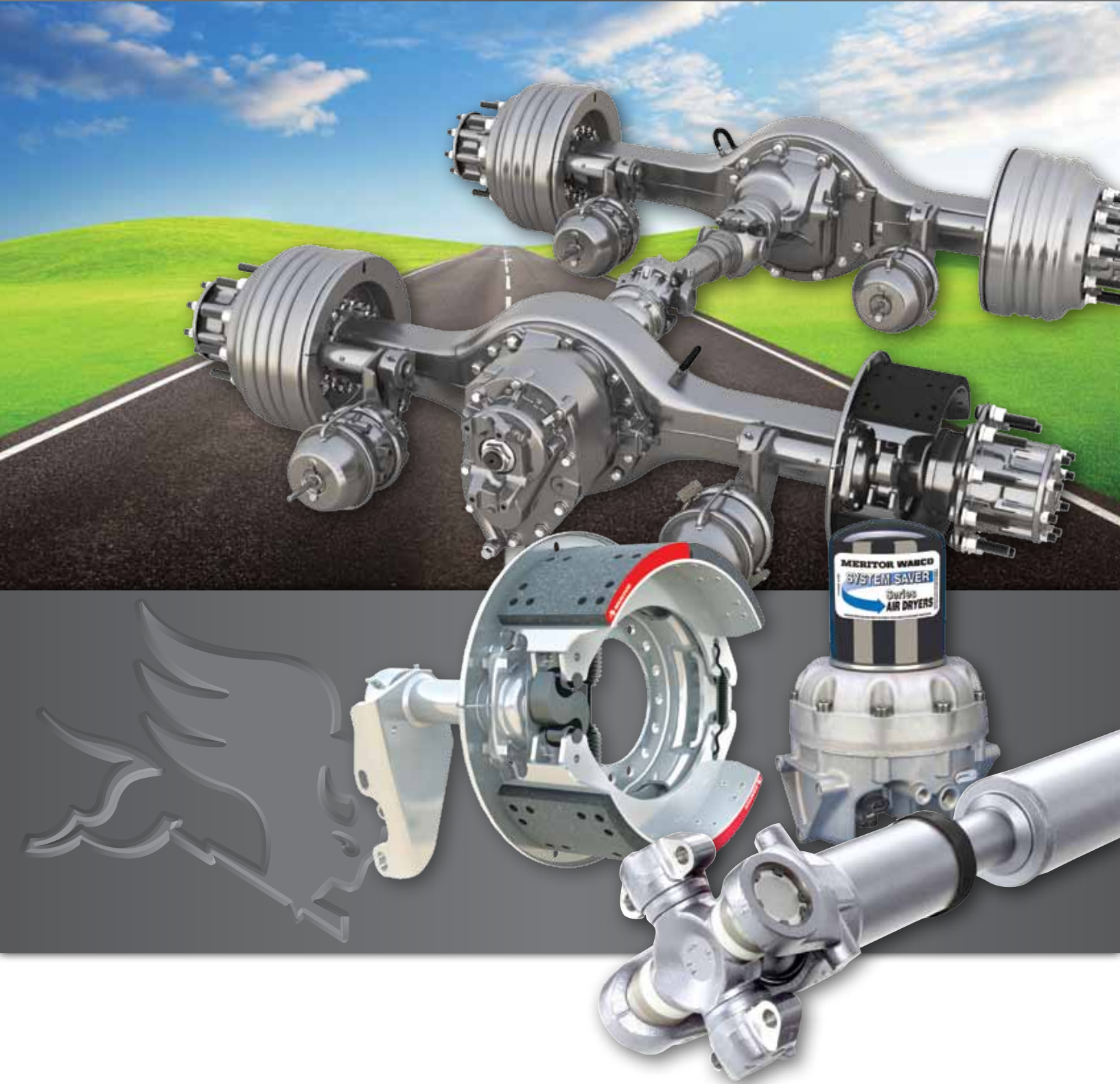

**MERITOR®**

### **Efficiency to run your business.**

Today, ever-increasing costs are putting intense pressure on already tight fleet operating margins. Equipment, labor and diesel fuel costs are all going up. The result is a financial burden that threatens the livelihoods of every trucking business. Yet the daunting challenge our industry faces is not merely financial, but environmental as well.

The need to increase commercial vehicle fuel economy while reducing greenhouse gas emissions has become the preeminent issue of our industry going forward.

Many of the solutions are at hand. In fact, many of those existing technologies are MPG SERIES components already manufactured by Meritor.

To help OEMs meet the challenge, our MPG SERIES delivers:

### **MPG = More Productivity Growth.**

MPG SERIES components are engineered to deliver superior operating efficiency with less downtime to equip you with a productivity gain.

### **MPG = Maximum Payload Gains.**

Stronger, yet lighter-weight MPG SERIES components enable your vehicles to haul more payload so you can move more tons per mile and earn more profits per mile.

### **MPG = Miles Per Gallon.\***

Fuel is your largest expense, and the MPG SERIES can help you cut that with components designed to optimize operation and lighten your truck. Comprised of both current products and future technologies, the MPG SERIES reflects Meritor's position as a worldwide technology leader.

\*The fuel savings described throughout are estimates only. Actual fuel savings may vary and will depend on a variety of factors beyond Meritor's control, including load, vehicle type, driver performance, distances traveled, vehicle speed, road conditions, etc."

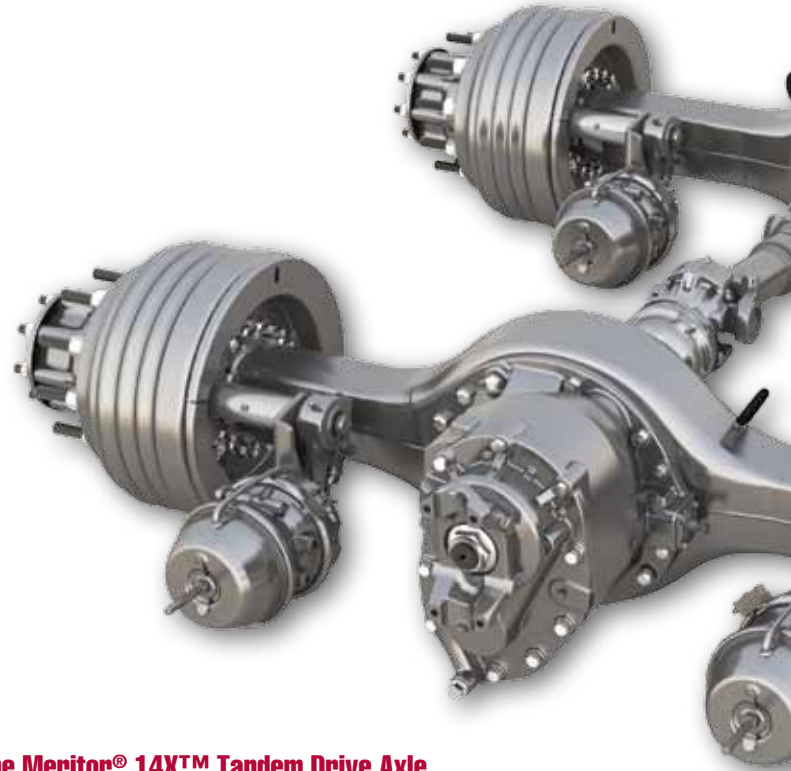

### **The Meritor® 14X™ Tandem Drive Axle. Raise your MPG Xpectations.**

The Meritor 14X Tandem Drive Axle delivers every benefit of its predecessor – the legendary Meritor RT-40-145 – and more. Including a more robust, 20% larger Inter-Axle Differential and the industry's fastest ratio – 2.47. The 14X features as standard equipment our premium Meritor Amboid™ design. And the optional DualTrac™ housing which addresses wheel bearing overload associated with the use of single wide-based tires. All of these great features at the lightest weight in its class.

- Fastest and widest range of ratios in the industry
  - 2.47 ratio is the fastest axle ratio in the industry and the most efficient solution for vehicles with direct drive transmissions
  - Lowering our fastest ratio to 2.47 from 2.64 drops engine rpms by 100 at cruise speed, offering potential fuel savings



### **DualTrac housing.**

- Reduced overall vehicle weight by optimizing the use of wide-based tires with DualTrac housing
  - This Meritor exclusive option eliminates over 800 pounds per tandem axle\* when used with wide-based single tires
  - Allows ability to convert between wide-based single tires and duals within legal axle spread dimensions
  - Provides bearing life equal to dual-tire-configured tandem axles
  - Offered in 9.5-mm and 11.0-mm housing wall thickness options



Courtesy of Bridgestone Bandag Tire Solutions

\*When combined with aluminum carriers, SteelLite X30™, super single tires and aluminum wheels

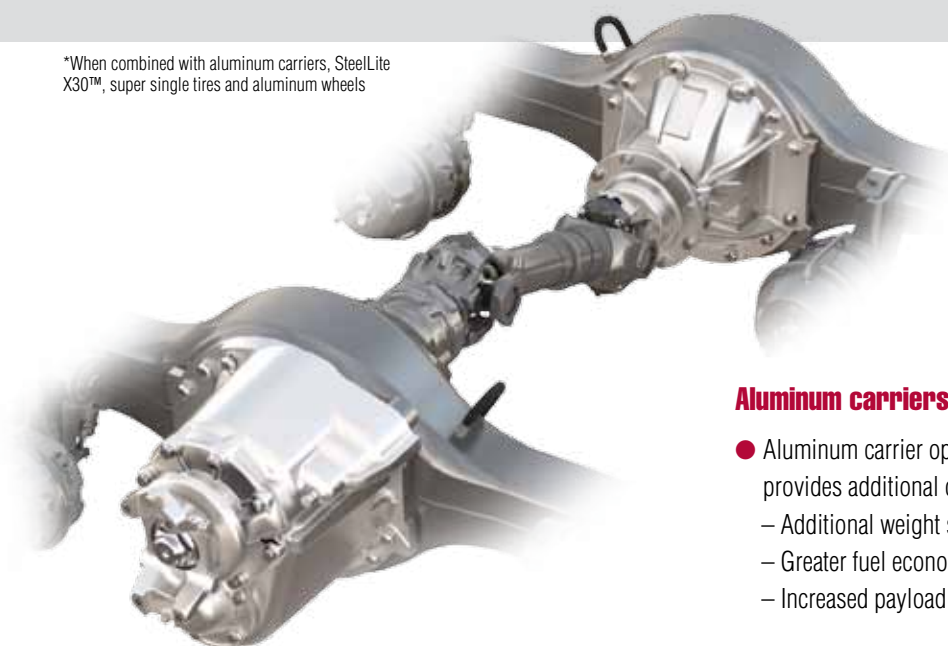

### **Aluminum carriers.**

- Aluminum carrier option, available on certain axle configurations, provides additional operating efficiencies:
  - Additional weight savings – up to 90 pounds per tandem
  - Greater fuel economy
  - Increased payload – without sacrificing strength

## **Meritor Q Plus™ Cam Brake with Stamped Steel Spider and Meritor Automatic Slack Adjuster (ASA). Saves weight and your brakes.**

The Meritor Q Plus cam brake combined with stamped steel spider saves 6.5 pounds per brake without sacrificing durability or performance. Integrated with the Meritor Automatic Slack Adjuster delivers an industry-leading lightweight package.

- Innovations for minimized maintenance and downtime
  - Optimized lining geometry for uniform wear and consistent performance
  - Enhanced camshaft bushing material
  - Double anchor pin design
  - Extended Lube option
- Best-in-class E-coat corrosion protection standard on all Q Plus brake shoes
- PlatinumShield™ Coating Technology option delivers premium protection against rust-jacking
- The unique Automatic Slack Adjuster design keeps the brake in constant adjustment
  - Eliminates the need for frequent under-the-truck brake adjustments
  - Lowers brake maintenance costs
  - Reduces vehicle safety inspection citations
- Greater parts commonality among steer, drive and trailer brakes for reduced parts inventory
- Specify SteelLite X30™ brake drums for additional weight savings

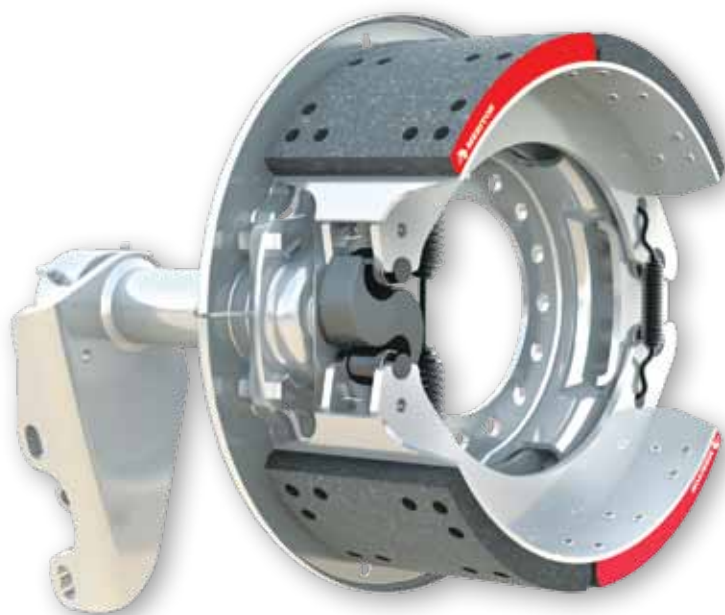

## **Meritor SteelLite X30™ Drums. Significant weight savings.**

Premium lightweight SteelLite X30 drums reduce vehicle weight by up to 300 pounds for a typical tandem-axle tractor/trailer combination.\*

- Reduces maintenance with a durable one-piece design that provides long operating life
- Provides lightweight package when specified with stamped steel spider, Q Plus cam brake and Meritor ASA
- Broad availability as original equipment and aftermarket replacement, plus interchangeability with comparable cast drums and linings for easy upgrade

\*As compared to the use of full-cast drums with 16-1/2" x 5" front brakes and 16-1/2" x 8-5/8" tandem rear and trailer brakes.



**Meritor Permalube™ RPL driveline.  
Permanently lubricated. Sealed for life.**

Our proven Permalube RPL drivelines are built and warranted for longevity. Permanently lubricated to reduce operating and maintenance costs, Permalube drivelines deliver longer U-joint life particularly on gear-fast/run-slow drivetrains.

- Industry-leading permanent lubrication technology for more than 15 years
- Nylon thrust washers eliminate metal-to-metal contact, preventing wear
- Advanced sealing features include E-coated, protected steel guard to hold seal in place; guards against contaminants/debris
- Installation is easy, requiring removal of only four bolts
- 4-Year/400,000-Mile linehaul warranty – a first in the industry

**Air Disc Brakes for tractors and trailers.  
Dependable stopping power. Longer life.**

Proven twin-piston air disc brake design for tractors and trailers enhance operational efficiency and deliver low cost of ownership.

- Lighter weight\* – facilitates increased payload and fuel savings
- Optimized stopping power – provides the shortest stopping distance
- Ease of maintenance – significantly reduces downtime during lining changes
- Higher efficiency – provides more responsive braking
- Optimized stability – provides more consistency in side-to-side torque output

\*Based on weight comparison to a tractor equipped with 16.5" x 5" front brakes and 16.5" x 8.625" rear brakes.

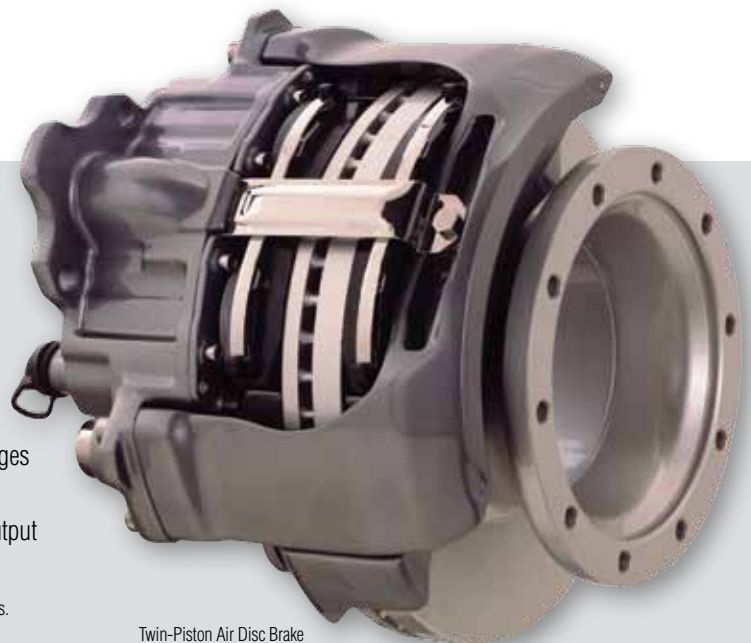

Twin-Piston Air Disc Brake



### **RideSentry™ MPA Tandem-Axle Trailer Air Suspensions (MPA38 and MPA40).**

**Increased operating efficiency. Reduced downtime.**

The RideSentry MPA38 and MPA40 Series trailer suspension, with its unique PinLoc System, makes it easy for drivers to secure the slider and get the vehicle moving. This saves time, reduces downtime and maintenance costs and helps to ensure prompt delivery.

With its integrated slider, trailer axles and brakes, RideSentry provides a lightweight, efficient package that also provides the most durable and stable ride on the market.

- Parallelogram suspension articulation increases uptime and reduces maintenance expenses
- Compact lightweight system delivers exceptionally smooth and stable ride and better handling for longer trailer life
- PinLoc combines industry-exclusive angled locking pins, parking brake interlock and push-button air assist to help protect against slider and trailer damage
- Delivers increased fuel economy and longer tire life, with its 100% air ride and unique bushing design
- Facilitates highly accurate alignment for efficient operation and superior vehicle control while minimizing tire wear

### **Meritor Tire Inflation System by P.S.I. with ThermALERT™ option.**

**Continuous protection. Continuous savings.**

The Meritor Tire Inflation System by P.S.I. with ThermALERT option is the market's leading continuous tire inflation system for trailers. It maintains optimum tire pressure continuously for safety, maximum fuel economy, longer tire life, reduced maintenance and increased uptime. All with optional wheel-end heat-sensor warning technology.

- Provides annual cost savings per trailer including fuel, tread wear, maintenance and tire replacement
- Prevents catastrophic failure and associated costs from running underinflated
- Continuously optimizes tire pressure to maximize payload





### **System Saver 1200 Plus Air Dryer. Reduces weight. Increases performance.**

The System Saver 1200 Plus Air Dryer delivers increased brake system protection from contamination while its reduced weight allows greater payloads.

- Reduces weight (at 19.8 pounds, it is the lightest integrated purge air dryer on the market)
- Replaceable spin-on cartridge takes less than five minutes to change
- Provides parts compatibility with previous models for easy replacement of purge valve and turbo cutoff valve
- Extends the life of other air brake system components via coalescing filter

### **Future MPG SERIES technology.**

At Meritor, we're celebrating over 100 years of "forward thinking" with a passion for introducing next-generation drivetrain product solutions that deliver real customer advantages through advanced design and state-of-the-art manufacturing technology.

As we continue to unveil new waves of MPG SERIES innovations, you can count on unsurpassed product performance, engineering expertise and committed customer service to continue to define Meritor's role as a world leader in commercial vehicle innovation.

### **Moving you forward. Behind you all the way.**

It takes strong heritage and an equally bold vision to innovate components and systems that revolutionize fleet efficiency. Meritor is the one global leader that offers it all – right now. No other manufacturer even comes close to providing the complete efficiency

### **Meritor WABCO OnGuard™ Collision Safety System. Also guards against unnecessary fuel consumption.**

OnGuard features Adaptive Cruise Control (ACC), which helps keep drivers in cruise longer, avoiding unnecessary shifting and hard accelerations, which translates to less fuel consumption. And as the first Collision Safety System with Active Braking, OnGuard uses forward-looking radar to monitor potential collisions ahead and helps drivers avoid or greatly reduce the impact of a collision.

- OnGuard eliminates speed changes and unnecessary fuel consumption while also maintaining a safe following distance
- As a result, the driver can spend more time in top gear, which saves fuel
- OnGuard is always on – even when you're not in cruise control

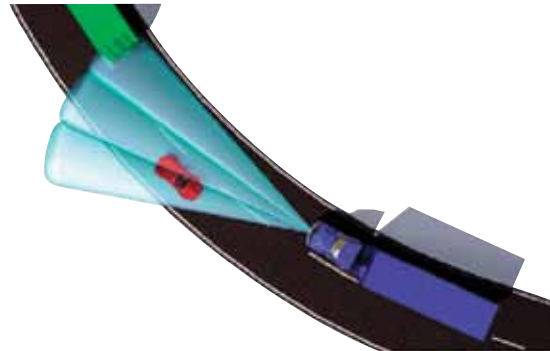

package that our Meritor MPG SERIES represents. Especially when you consider the unsurpassed aftermarket support, the industry's most knowledgeable, committed reps, dedicated customer service and technical support, complete online catalogs, expert training programs, and comprehensive product warranty support. Meritor delivers the advantages you need for today. And tomorrow.

### **Want Next-Generation fleet efficiency? Let's talk.**

For more information about how our next-generation MPG SERIES components can significantly increase your operating efficiency, see your truck or trailer dealer today or visit [meritor.com](http://meritor.com).



Meritor Heavy Vehicle Systems, LLC  
2135 West Maple Road  
Troy, Michigan 48084 USA

For more information,  
call OnTrac at **866-668-7221**  
or visit **[meritor.com](http://meritor.com)**.

Litho in USA Revised 11-11  
SP-1083 (47865/11900)  
©2011 Meritor, Inc.

Vehicle models, brands and names depicted herein are the property of their respective owners, and are not in any way associated with Meritor, Inc., or its affiliates.