

**ANTI-LOCK BRAKING SYSTEM
(ABS) FOR TRUCKS, TRACTORS
AND BUSES:
FOR D VERSION ECUs**

MAINTENANCE MANUAL



WABCO

Before You Begin

This manual provides correct service and repair procedures for WABCO's anti-lock braking system for trucks, tractors and buses. Before you begin procedures:

1. Read and understand all instructions and procedures before you begin to service components.
2. Read and observe all Caution and Warning safety alerts that precede instructions or procedures you will perform. These alerts help to avoid damage to components, serious personal injury, or both.
3. Follow your company's maintenance and service, installation, and diagnostics guidelines.
4. Use special tools when required to help avoid serious personal injury and damage to components.

Safety Alerts, Torque Symbol and Notes

| | |
|--|---|
|  WARNING | A Warning alerts you to an instruction or procedure that you must follow exactly to avoid serious personal injury and damage to components. |
|  CAUTION | A Caution alerts you to an instruction or procedure that you must follow exactly to avoid damage to components and possible serious injury. |

| | |
|---|---|
|  | A torque symbol alerts you to tighten fasteners to a specified torque value. |
| NOTE | A Note provides information or suggestions that help you correctly service a component. |

Access Information on WABCO's Web Site

Additional maintenance and service information for WABCO's commercial vehicle systems component lineup is also available at www.wabco-auto.com.

Additional Information

Call WABCO North America Customer Care at 855-228-3203 to order the following item.

| | |
|--|----|
|  Asbestos and Non-Asbestos Fibers Warnings | 1 |
| Section 1: Introduction | |
| Contents | 3 |
| How ABS Works | |
| ECU Identification | |
| ABS Configuration | 4 |
| ABS Indicator Lamp | 5 |
| ABS Modulator Valves | |
| Valve Arrangement Option | |
| ABS Valve Packages | 6 |
| ABS Sensors | 7 |
| Automatic Traction Control | |
| Off-Road ABS | |
| System Components | 8 |
| Section 2: Automatic Traction Control (ATC) | |
| ATC | 11 |
| Deep Snow and Mud Switch | |
| ATC Components | |
| Section 3: Troubleshooting & Testing | |
| General Maintenance Information | 13 |
| System Diagnostics | |
| TOOLBOX Software | |
| Blink Code Diagnostics | 15 |
| Diagnostic Mode | |
| Clear Mode | |
| Blink Code Diagnostics | 16 |
| Working with Blink Codes | 18 |
| Blink Code Troubleshooting and Repair | 20 |
| J1922 or J1939 Datalink Verification | 21 |
| Component Tests and Functions | 22 |
| TOOLBOX Software | |
| MPSI Pro-Link 9000 | 24 |
| Component Tests | |
| Diagnostic and Testing Procedure | |
| Pro-Link Screens | 25 |
| Using the Pro-Link | |
| Tire Size Range | 28 |
| Testing Components | |
| Voltage Check | |
| Location of Sensors | |
| Sensor Adjustment | 29 |
| Sensor Output Voltage Test | |
| Sensor Resistance | |
| Dynamometer Testing Vehicles with ATC | |
| Valve Tests | 30 |
| ABS Modulator Valve | |
| ATC Valve | |

Section 4: Component Replacement

| | |
|---|----|
| Component Removal and Installation | 31 |
| Valves | |
| Sensor Lube Specification | |
| Sensors | |
| Valves | 33 |
| ABS Modulator Valve | |
| ATC Valve | 34 |
| Front or Rear ABS Valve Package | 35 |
| ATC Valve on the Rear ABS Valve Package | 36 |

Appendix I: System Configuration Layouts 39**Appendix II: Wiring Diagrams** 41**Appendix III: Additional ABS Information**

| | |
|---|----|
| Troubleshooting Guide — WABCO ABS Valve Package | 48 |
| Reconfiguration Procedure | 49 |
| How to Reconfigure an ECU (D Version) | |

**ASBESTOS FIBERS WARNING**

The following procedures for servicing brakes are recommended to reduce exposure to asbestos fiber dust, a cancer and lung disease hazard. Material Safety Data Sheets are available from WABCO.

Hazard Summary

Because some brake linings contain asbestos, workers who service brakes must understand the potential hazards of asbestos and precautions for reducing risks. Exposure to airborne asbestos dust can cause serious and possibly fatal diseases, including asbestosis (a chronic lung disease) and cancer, principally lung cancer and mesothelioma (a cancer of the lining of the chest or abdominal cavities). Some studies show that the risk of lung cancer among persons who smoke and who are exposed to asbestos is much greater than the risk for non-smokers. Symptoms of these diseases may not become apparent for 15, 20 or more years after the first exposure to asbestos.

Accordingly, workers must use caution to avoid creating and breathing dust when servicing brakes. Specific recommended work practices for reducing exposure to asbestos dust follow. Consult your employer for more details.

Recommended Work Practices

1. Separate Work Areas. Whenever feasible, service brakes in a separate area away from other operations to reduce risks to unprotected persons. OSHA has set a maximum allowable level of exposure for asbestos of 0.1 f/cc as an 8-hour time-weighted average and 1.0 f/cc averaged over a 30-minute period. Scientists disagree, however, to what extent adherence to the maximum allowable exposure levels will eliminate the risk of disease that can result from inhaling asbestos dust. OSHA requires that the following sign be posted at the entrance to areas where exposures exceed either of the maximum allowable levels:

**DANGER: ASBESTOS
CANCER AND LUNG DISEASE HAZARD
AUTHORIZED PERSONNEL ONLY
RESPIRATORS AND PROTECTIVE CLOTHING
ARE REQUIRED IN THIS AREA**

2. Respiratory Protection. Wear a respirator equipped with a high-efficiency (HEPA) filter approved by NIOSH or MSHA for use with asbestos at all times when servicing brakes, beginning with the removal of the wheels.

3. Procedures for Servicing Brakes.

- a. Enclose the brake assembly within a negative pressure enclosure. The enclosure should be equipped with a HEPA vacuum and worker arm sleeves. With the enclosure in place, use the HEPA vacuum to loosen and vacuum residue from the brake parts.
- b. As an alternative procedure, use a catch basin with water and a biodegradable, non-phosphate, water-based detergent to wash the brake drum or rotor and other brake parts. The solution should be applied with low pressure to prevent dust from becoming airborne. Allow the solution to flow between the brake drum and the brake support or the brake rotor and caliper. The wheel hub and brake assembly components should be thoroughly wetted to suppress dust before the brake shoes or brake pads are removed. Wipe the brake parts clean with a cloth.
- c. If an enclosed vacuum system or brake washing equipment is not available, employers may adopt their own written procedures for servicing brakes, provided that the exposure levels associated with the employer's procedures do not exceed the levels associated with the enclosed vacuum system or brake washing equipment. Consult OSHA regulations for more details.
- d. Wear a respirator equipped with a HEPA filter approved by NIOSH or MSHA for use with asbestos when grinding or machining brake linings. In addition, do such work in an area with a local exhaust ventilation system equipped with a HEPA filter.
- e. **NEVER** use compressed air by itself, dry brushing, or a vacuum not equipped with a HEPA filter when cleaning brake parts or assemblies. **NEVER** use carcinogenic solvents, flammable solvents, or solvents that can damage brake components as wetting agents.

4. Cleaning Work Areas. Clean work areas with a vacuum equipped with a HEPA filter or by wet wiping. **NEVER** use compressed air or dry sweeping to clean work areas. When you empty vacuum cleaners and handle used rags, wear a respirator equipped with a HEPA filter approved by NIOSH or MSHA for use with asbestos. When you replace a HEPA filter, wet the filter with a fine mist of water and dispose of the used filter with care.

5. Worker Clean-Up. After servicing brakes, wash your hands before you eat, drink or smoke. Shower after work. Do not wear work clothes home. Use a vacuum equipped with a HEPA filter to vacuum work clothes after they are worn. Launder them separately. Do not shake or use compressed air to remove dust from work clothes.

6. Waste Disposal. Dispose of discarded linings, used rags, cloths and HEPA filters with care, such as in sealed plastic bags. Consult applicable EPA, state and local regulations on waste disposal.

Regulatory Guidance

References to OSHA, NIOSH, MSHA, and EPA, which are regulatory agencies in the United States, are made to provide further guidance to employers and workers employed within the United States. Employers and workers employed outside of the United States should consult the regulations that apply to them for further guidance.

**NON-ASBESTOS FIBERS WARNING**

The following procedures for servicing brakes are recommended to reduce exposure to non-asbestos fiber dust, a cancer and lung disease hazard. Material Safety Data Sheets are available from WABCO.

Hazard Summary

Most recently manufactured brake linings do not contain asbestos fibers. These brake linings may contain one or more of a variety of ingredients, including glass fibers, mineral wool, aramid fibers, ceramic fibers and silica that can present health risks if inhaled. Scientists disagree on the extent of the risks from exposure to these substances. Nonetheless, exposure to silica dust can cause silicosis, a non-cancerous lung disease. Silicosis gradually reduces lung capacity and efficiency and can result in serious breathing difficulty. Some scientists believe other types of non-asbestos fibers, when inhaled, can cause similar diseases of the lung. In addition, silica dust and ceramic fiber dust are known to the State of California to cause lung cancer. U.S. and international agencies have also determined that dust from mineral wool, ceramic fibers and silica are potential causes of cancer.

Accordingly, workers must use caution to avoid creating and breathing dust when servicing brakes. Specific recommended work practices for reducing exposure to non-asbestos dust follow. Consult your employer for more details.

Recommended Work Practices

1. Separate Work Areas. Whenever feasible, service brakes in a separate area away from other operations to reduce risks to unprotected persons.

2. Respiratory Protection. OSHA has set a maximum allowable level of exposure for silica of 0.1 mg/m³ as an 8-hour time-weighted average. Some manufacturers of non-asbestos brake linings recommend that exposures to other ingredients found in non-asbestos brake linings be kept below 1.0 f/cc as an 8-hour time-weighted average. Scientists disagree, however, to what extent adherence to these maximum allowable exposure levels will eliminate the risk of disease that can result from inhaling non-asbestos dust.

Therefore, wear respiratory protection at all times during brake servicing, beginning with the removal of the wheels. Wear a respirator equipped with a high-efficiency (HEPA) filter approved by NIOSH or MSHA, to minimize exposure. Even when exposures are expected to be within the maximum allowable levels, wearing such a respirator at all times during brake servicing will help minimize exposure.

3. Procedures for Servicing Brakes.

- a. Enclose the brake assembly within a negative pressure enclosure. The enclosure should be equipped with a HEPA vacuum and worker arm sleeves. With the enclosure in place, use the HEPA vacuum to loosen and vacuum residue from the brake parts.
- b. As an alternative procedure, use a catch basin with water and a biodegradable, non-phosphate, water-based detergent to wash the brake drum or rotor and other brake parts. The solution should be applied with low pressure to prevent dust from becoming airborne. Allow the solution to flow between the brake drum and the brake support or the brake rotor and caliper. The wheel hub and brake assembly components should be thoroughly wetted to suppress dust before the brake shoes or brake pads are removed. Wipe the brake parts clean with a cloth.
- c. If an enclosed vacuum system or brake washing equipment is not available, carefully clean the brake parts in the open air. Wet the parts with a solution applied with a pump-spray bottle that creates a fine mist. Use a solution containing water, and, if available, a biodegradable, non-phosphate, water-based detergent. The wheel hub and brake assembly components should be thoroughly wetted to suppress dust before the brake shoes or brake pads are removed. Wipe the brake parts clean with a cloth.
- d. Wear a respirator equipped with a HEPA filter approved by NIOSH or MSHA when grinding or machining brake linings. In addition, do such work in an area with a local exhaust ventilation system equipped with a HEPA filter.
- e. **NEVER** use compressed air by itself, dry brushing, or a vacuum not equipped with a HEPA filter when cleaning brake parts or assemblies. **NEVER** use carcinogenic solvents, flammable solvents, or solvents that can damage brake components as wetting agents.

4. Cleaning Work Areas. Clean work areas with a vacuum equipped with a HEPA filter or by wet wiping. **NEVER** use compressed air or dry sweeping to clean work areas. When you empty vacuum cleaners and handle used rags, wear a respirator equipped with a HEPA filter approved by NIOSH or MSHA, if the exposure levels may exceed OSHA or manufacturers' recommended maximum levels. When you replace a HEPA filter, wet the filter with a fine mist of water and dispose of the used filter with care.

5. Worker Clean-Up. After servicing brakes, wash your hands before you eat, drink or smoke. Shower after work. Do not wear work clothes home. Use a vacuum equipped with a HEPA filter to vacuum work clothes after they are worn. Launder them separately. Do not shake or use compressed air to remove dust from work clothes.

6. Waste Disposal. Dispose of discarded linings, used rags, cloths and HEPA filters with care, such as in sealed plastic bags. Consult applicable EPA, state and local regulations on waste disposal.

Regulatory Guidance

References to OSHA, NIOSH, MSHA, and EPA, which are regulatory agencies in the United States, are made to provide further guidance to employers and workers employed within the United States. Employers and workers employed outside of the United States should consult the regulations that apply to them for further guidance.

Contents

This manual contains service information for the WABCO Anti-Lock Braking System (ABS) and ABS with Automatic Traction Control (ATC) for trucks, tractors and buses. Use this manual for D version, cab- and frame-mounted and D Basic Electronic Control Units (ECUs).

For diagnostic and testing procedures for systems with C version ECUs, use Maintenance Manual 28.

How ABS Works

WABCO ABS is an electronic system that monitors and controls wheel speed during braking. The system works with standard air brake systems.

ABS monitors wheel speeds at all times and controls braking during wheel lock situations. The system improves vehicle stability and control by reducing wheel lock during braking.

The ECU receives and processes signals from the wheel speed sensors. When the ECU detects a wheel lockup, the unit activates the appropriate modulator valve, and air pressure is controlled.

In the event of a malfunction in the system, the ABS in the affected wheel(s) is disabled; that wheel still has normal brakes. The other wheels keep the ABS function.

An ABS indicator lamp lets drivers know the status of the system. This lamp is also used to display blink code diagnostics. **Figure 1.1.** The location of the ABS indicator lamp varies, depending on the make and model of the vehicle.

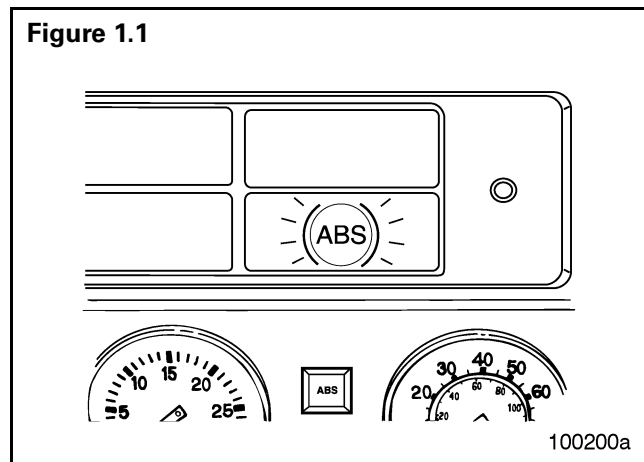

ECU Identification

NOTE: Do not open the ECU. Opening the ECU to gain access to the internal components will void the warranty.

C and D version ECUs are easy to distinguish. **Figure 1.2 and Figure 1.3.**

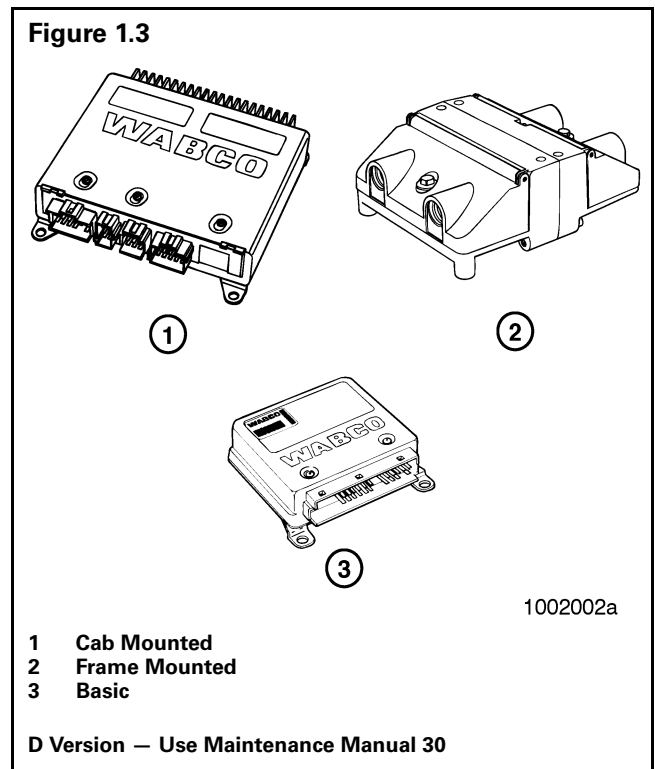
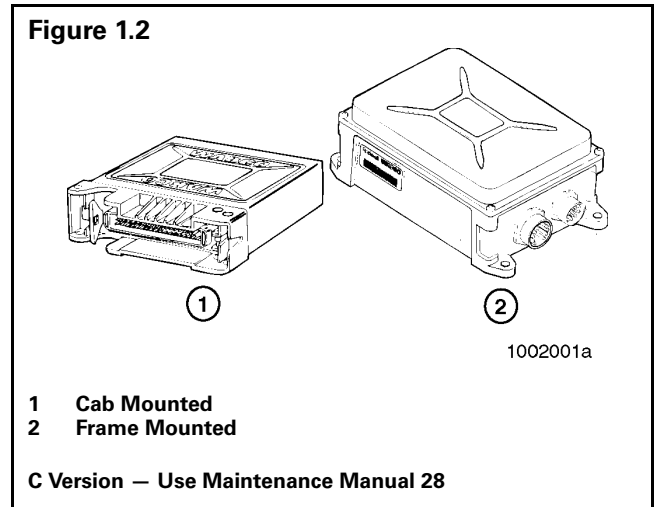

Section 1 Introduction

The ECU version, C or D, appears on the part number identification tag. **Figure 1.4.**

If you cannot identify the ECU version installed on your vehicle, contact WABCO North America Customer Care at 855-228-3203.

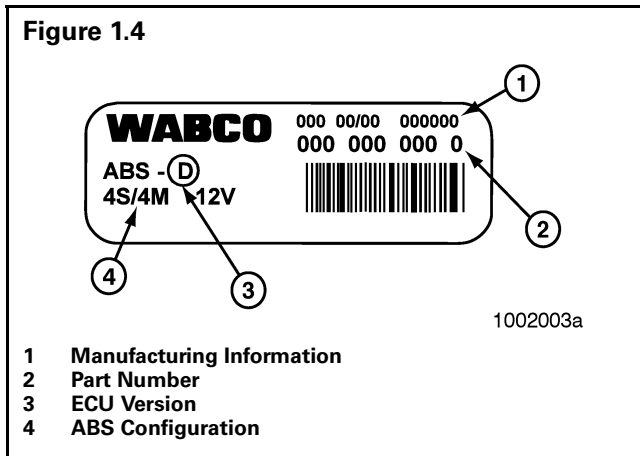

ABS Configuration

NOTE: With D Basic, 4S/4M is the only configuration used.

The ABS configuration is defined by the number of wheel end sensors and modulator valves. There are three common ABS configurations used with D version ECUs:

- 4S/4M (4 wheel speed sensors, 4 modulator valves) **Figure 1.5.**
- 6S/4M (6 wheel speed sensors, 4 modulator valves)
- 6S/6M (6 wheel speed sensors, 6 modulator valves)

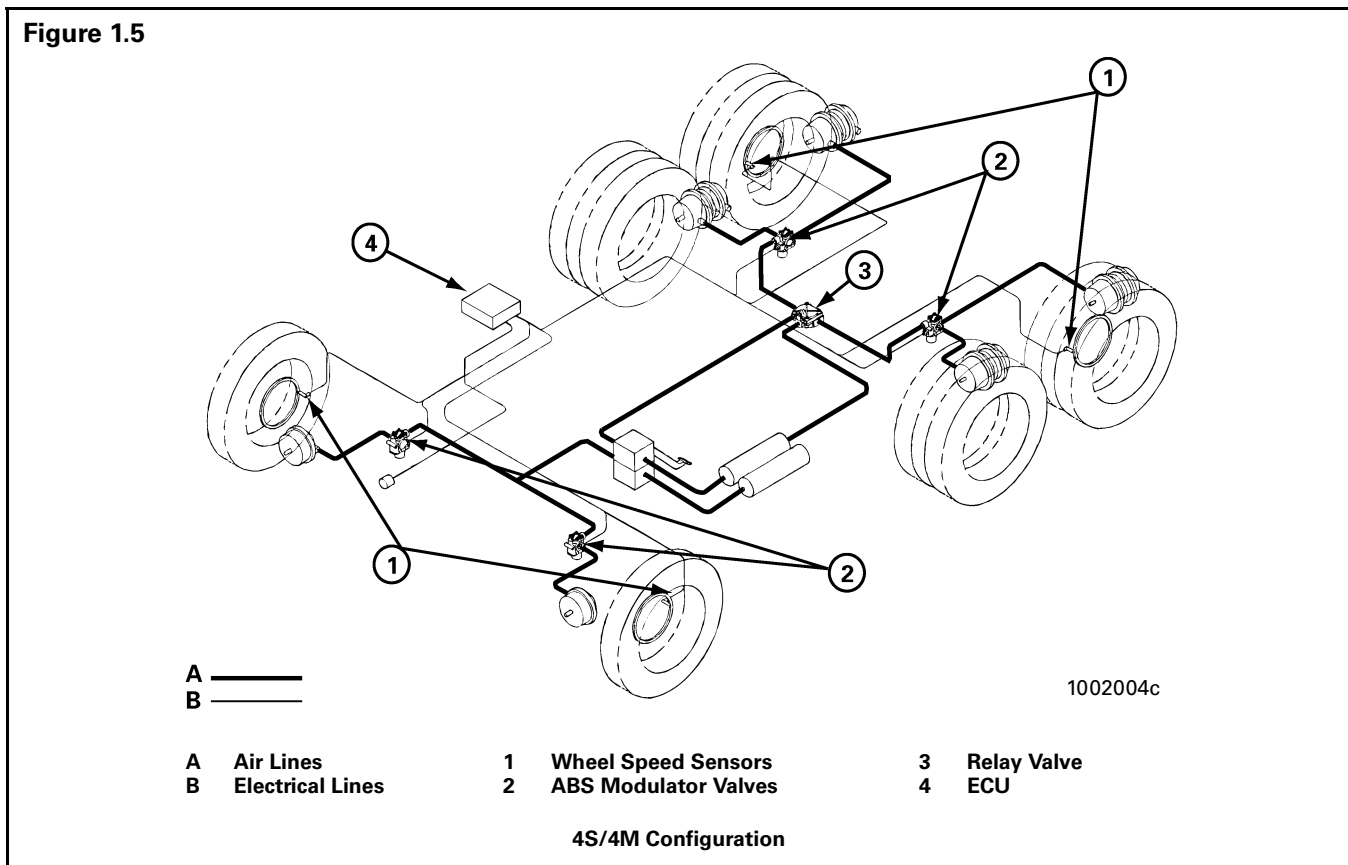

NOTE: Typical illustrations in this manual use the 4S/4M configuration as a sample. Layouts for 4S/4M, 6S/4M, and 6S/6M configurations are included in **Appendix I.**

ABS Indicator Lamp

The ABS indicator lamp works as follows:

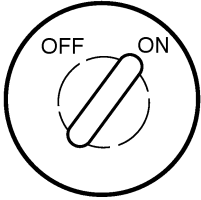
| | | | |
|---|--|--|---|
| <p>Ignition ON</p>  | Normal Operation | ABS lamp comes on at ignition momentarily for a bulb check, then goes out. | System is O.K. |
| | After servicing ABS | ABS lamp does not go out at ignition. | When vehicle is driven at speeds above 4 mph (6 km/h), lamp goes out. System is O.K. |
| | Off-road ABS operation. Refer to "Off-Road ABS" in this section. | ABS lamp flashes during vehicle operation. | The vehicle's normal ABS function is being modified due to road conditions. |
| | Existing Fault | ABS lamp does not go out at ignition. | Lamp does not go out at speeds above 4 mph (6 km/h) — a fault exists in the ABS system. |

NOTE: If the ECU senses a fault during normal vehicle operation, the ABS indicator lamp will come on and stay on.

ABS Modulator Valves

Modulator valves control the air pressure to each affected brake during an ABS function.

Valve Arrangement Option

In **Figure 1.5**, the modulator valves on the rear axle are mounted separately and a relay valve is used to deliver air pressure to the modulator valves. There is also an optional valve package available from WABCO, the **ABS Valve Package**, which may be found on certain vehicle models. The ABS valve package may be used on all D version units, including D Basic, and is available for front or rear axle installation.

Easy Listening Tip!

To make sure the ABS valves are working — just listen! Refer to **Figure 1.6**.

1. Apply the brakes.
2. Turn on the ignition.
3. Wait for the ABS indicator lamp to come on.
4. Listen to the valves cycle one by one, then together diagonally, as follows:
 - 4 Channel Valve Cycle Order: 1 – 2 – 3 – 4, then 1 & 2 – 3 & 4
 - 6 Channel Valve Cycle Order: 1 – 2 – 3 – 4 – 5 – 6, then 1, 2 & 3, 4, 5 & 6

Figure 1.6

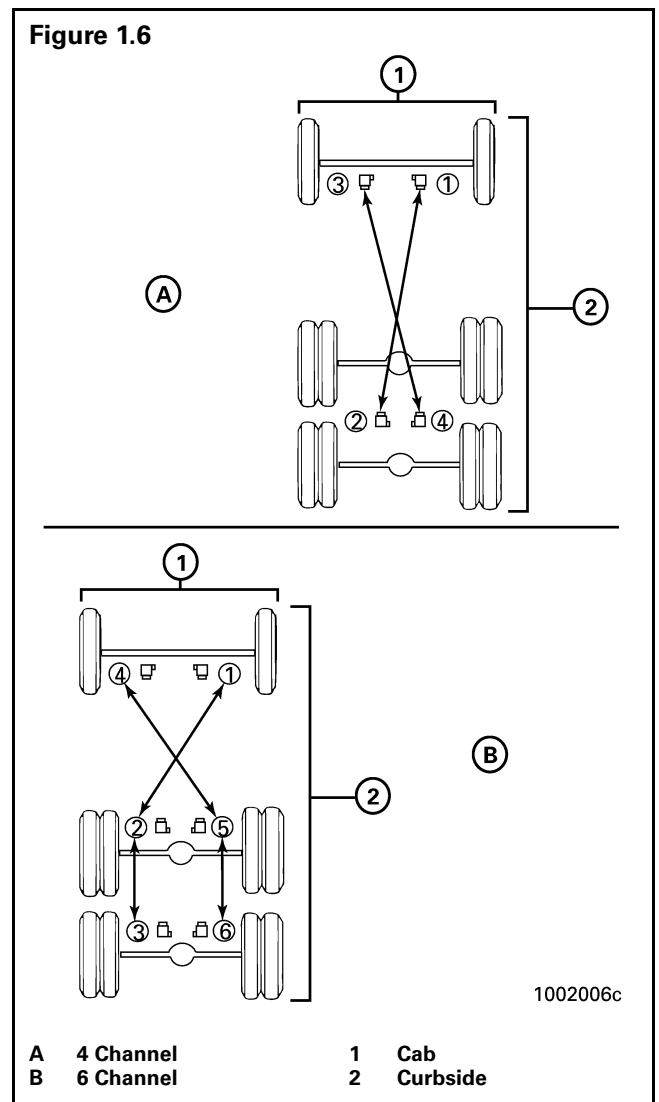

ABS Valve Packages

The front ABS valve package combines a quick release valve with two ABS modulator valves and is mounted in the front of the vehicle. The rear ABS valve package combines a service brake relay valve with two ABS modulator valves and is mounted in the rear of the vehicle. The valve package — front or rear — must be mounted near the brake chambers it serves. **Figure 1.7.**

Figure 1.7

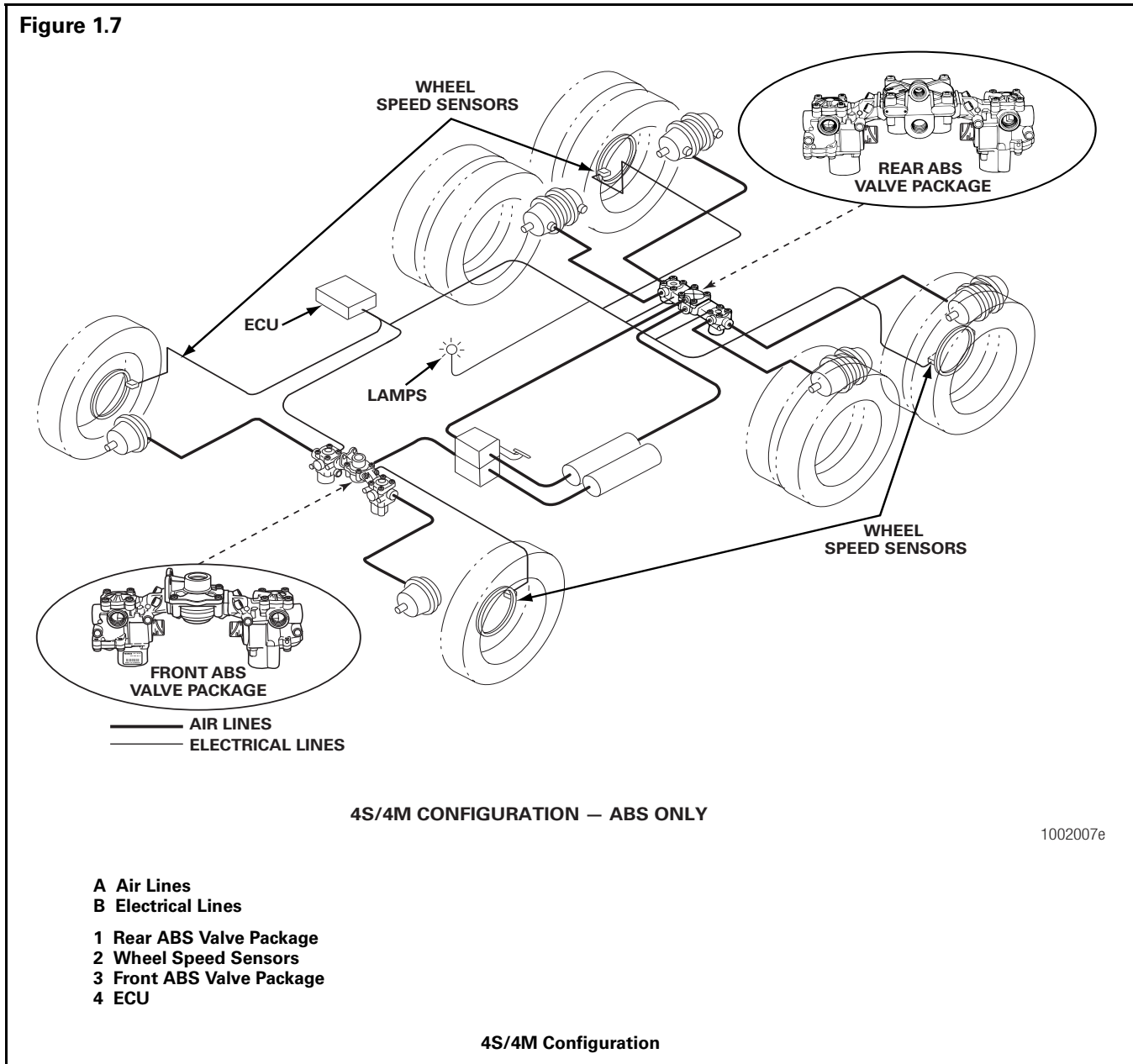

1002007e

ABS Sensors

ABS sensor systems consist of a tooth wheel mounted on the hub of each monitored wheel and a sensor installed so that its end is against the tooth wheel. The sensor continuously sends wheel speed information to the ECU. A sensor clip holds the sensor in place at the tooth wheel.

The type of axle determines sensor mounting location:

- Steering axle sensors are installed in the steering knuckle or in a bolted-on bracket.
- Drive axle sensors are mounted in a block attached to the axle housing or in a bolted-on bracket.

Automatic Traction Control

Automatic Traction Control (ATC) is available as an option on ABS truck, tractor and bus applications. ATC can be used with individual valves, or with an integrated ABS/ATC valve package. Section 2 describes ATC in detail.

Off-Road ABS

On some vehicles, an off-road ABS function may be selected. This optional feature improves vehicle control and helps reduce stopping distances in off-road conditions or on poor traction surfaces such as loose gravel, sand and dirt.

NOTE: On vehicles equipped with an off-road switch, the off-road ABS mode is manually selected by the driver. On some vehicles, the off-road mode may be fully automatic. Refer to the vehicle specifications for information about the off-road ABS feature.

The ABS indicator lamp on the dash will flash while the vehicle is in the off-road mode. This alerts the driver that the vehicle's normal ABS function is being modified.

System Components

Figure 1.8

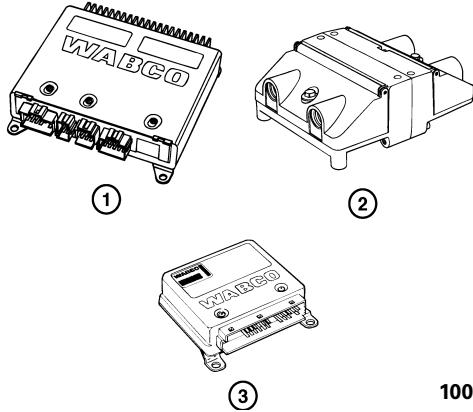

1002008a

- 1 Cab-Mounted ECU
- 2 Frame-Mounted ECU
- 3 D Basic ECU

The ECU is the brain of the ABS system. It receives information from the sensors and sends signals to the ABS valves. ECUs are available for cab- or frame-mounted applications. D Basic is a cab-mounted ECU. **Figure 1.8.**

Figure 1.9

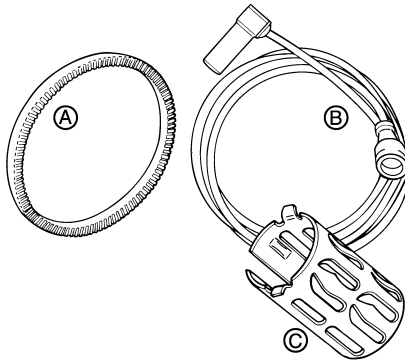

1002009b

A tooth wheel (A) is mounted at, or cast in, the hub of each sensed wheel, with a sensor (B) installed so that its end is against the tooth wheel. A sensor clip (C) holds the sensor in place at the tooth wheel. **Figure 1.9.**

NOTE: The sensor and clip must be greased with WABCO-recommended lubricant. Refer to "Sensor Lube Specification" in Section 4 for lube specification.

Figure 1.10

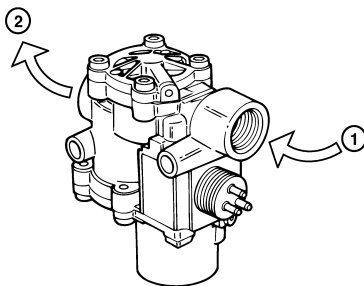

1002010b

- 1 Air In (Port 1)
- 2 Air Out (Port 2)

An **ABS modulator valve** controls air pressure to each affected brake during an ABS event. **Figure 1.10.** The modulator valve is usually located on a frame rail or cross member near the brake chamber.

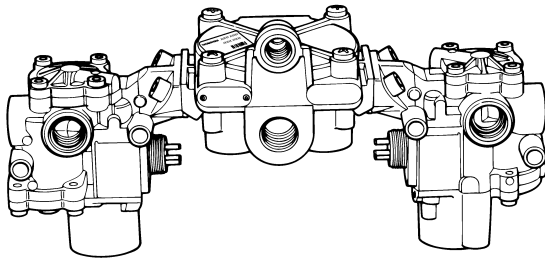
Figure 1.11

1002011

The **ABS valve package** is an alternative to individual valves.

The **rear ABS valve package** combines two modulator valves and one service relay valve. **Figure 1.11.**

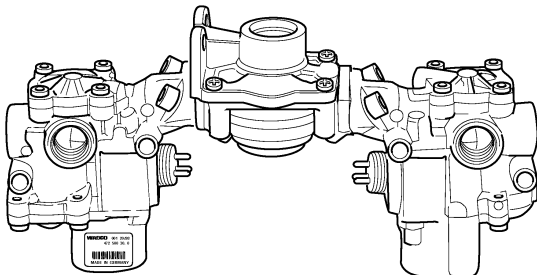
Figure 1.12

1003359a

The **front ABS valve package** combines two modulator valves and a quick release valve. **Figure 1.12.**

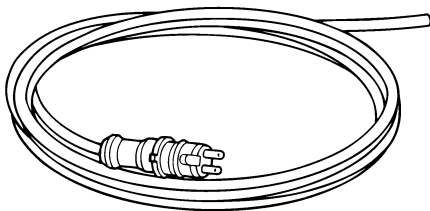
Figure 1.13

1002013a

Sensor cables connect the sensor to the ECU. **Figure 1.13.**

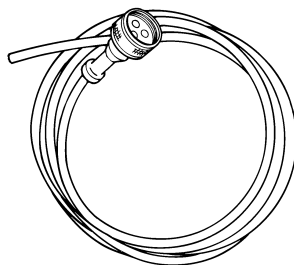
Figure 1.14

1002013a

ABS modulator valve cables connect the modulator valve to the ECU. **Figure 1.14.**

Figure 1.15

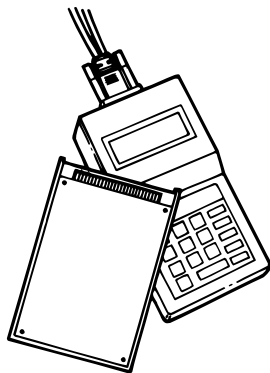

1002014a

Available from SPX (Kent-Moore), 800-328-6657

The **MPSI Pro-Link® 9000** with WABCO cartridge provides diagnostic and testing capabilities for the ABS system. **Figure 1.15.**

Figure 1.16

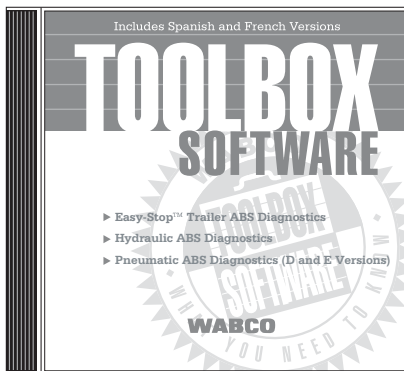

1005521b

Available from SPX (Kent-Moore), 800-328-6657

TOOLBOX Software is a PC-based diagnostics program that can display wheel speed data, test individual components, verify installation wiring and more. Runs in Windows® 95, 98 and NT. An RS232 to J1708 convertor box is required. Versions 3.2 and higher support E version ABS.

ATC

NOTE: ATC is not available on D Basic systems.

Automatic Traction Control (ATC) is an option available on ABS-equipped vehicles. It helps improve traction when vehicles are on slippery surfaces by reducing drive wheel overspin. ATC works automatically in two different ways:

1. If a drive wheel starts to spin, ATC applies air pressure to brake the wheel. This transfers engine torque to the wheels with better traction.
2. If all drive wheels spin, ATC reduces engine torque to provide improved traction.

ATC turns itself on and off, drivers do not have to select this feature. If drive wheels spin during acceleration, the ATC indicator lamp comes on, indicating ATC is active. It goes out when the drive wheels stop spinning. **Figure 2.1.**

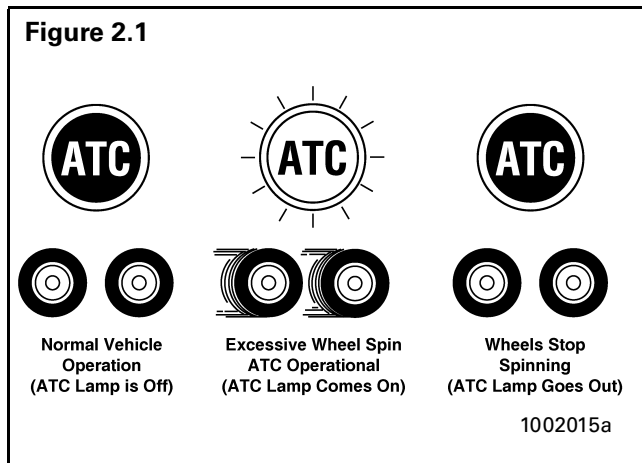

If ATC is installed, there will be an indicator lamp on the vehicle dash or instrument panel marked ATC, ASR, or Wheel Spin. Some vehicles without ATC have a wheel speed lamp to show if drive wheels are spinning.

If the ATC lamp goes out before the ABS lamp, there is no ATC.

An ATC installation may use an individually mounted valve, or the valve may be part of the ABS valve package. **Figure 2.2 and Figure 2.3.**

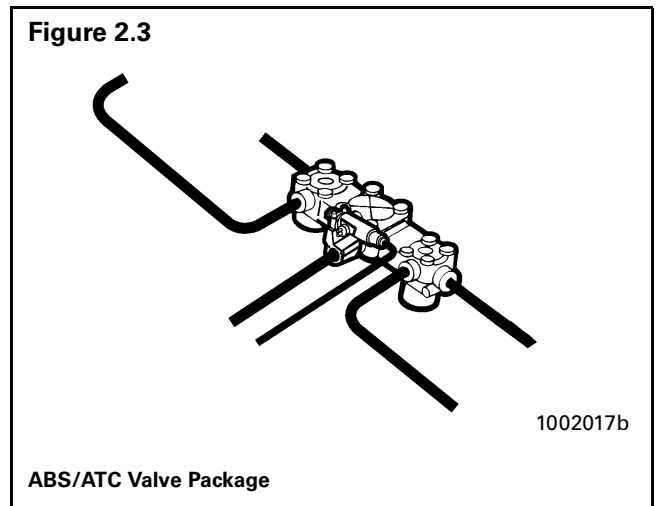
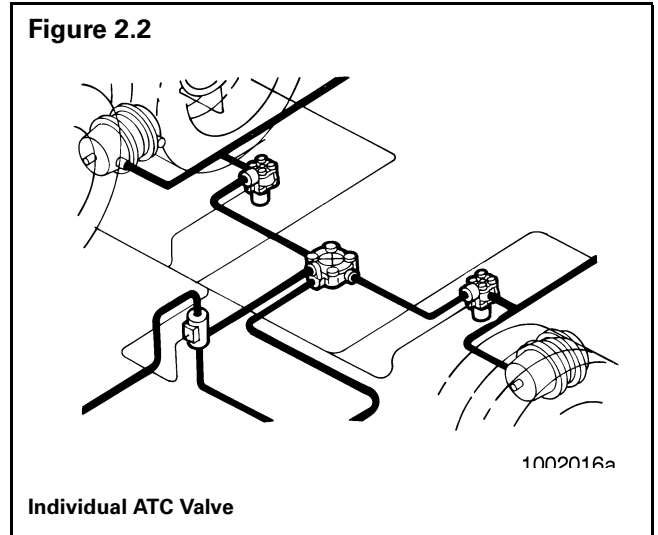

Deep Snow and Mud Switch

A deep snow and mud option switch is included with ATC. This function increases available traction on extra soft surfaces like snow, mud or gravel, by slightly increasing the permissible wheel spin.

Drivers use a deep snow and mud switch to select this feature. When this function is in use, the ATC indicator lamp blinks continuously. **Figure 2.4.**

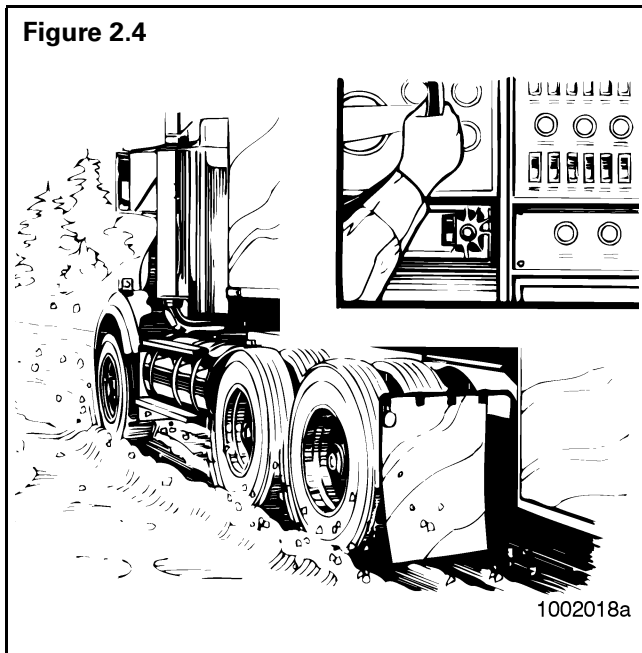

Switch and lamp locations will vary, depending on the vehicle make and model.

Here's how the Deep Snow and Mud feature works:

| Driver Action | System Response | Function | |
|--------------------------------|------------------------------|----------|------------|
| | | Active | Not Active |
| Press deep snow and mud switch | ATC lamp blinks continuously | X | |
| Press switch again | ATC lamp stops blinking | | X |

NOTE: Turning off the ignition will also deactivate the deep snow and mud feature.

ATC Components

ATC may be used with individual ABS modulator valves, or installed with the ABS Valve Package.

When installed with individual ABS modulator valves, an ATC solenoid valve is mounted on the frame or cross member, near the rear of the vehicle.

When it is part of the ABS valve package, an ATC valve is attached to the relay valve.

A cable connects the ECU to the ATC valve.

ATC components are illustrated in **Figure 2.5.**

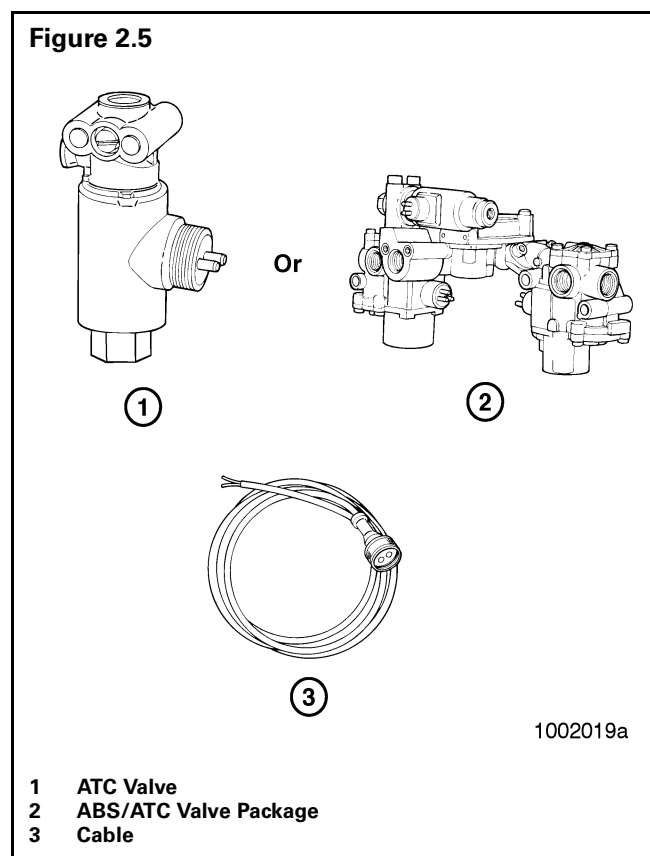

General Maintenance Information

There is no regularly scheduled maintenance required for the WABCO ABS or ABS/ATC. However, ABS does not change current vehicle maintenance requirements.

LAMP CHECK

To make sure the ABS lamp is operating, drivers should check the lamp every time the vehicle is started. When the vehicle is started, the ABS lamp should come on momentarily. If it does not come on, it could mean a burned-out bulb.

System Diagnostics

- TOOLBOX Software
- Blink Code Diagnostics
- Pro-Link 9000
- OEM Diagnostic Displays (refer to Vehicle Operator's Manual)

TOOLBOX Software

NOTE: For complete instructions for using TOOLBOX Software, refer to the User's Manual.

If you have TOOLBOX Software installed on your computer, use it to identify system faults. Then, follow the on-screen repair information to make the necessary repairs or replacements.

To display E version ABS faults:

1. Connect the computer to the vehicle:
 - Attach the cable from your computer to the J1708 to RS232 converter box.
 - Attach the diagnostic cable (Deutsch) to the vehicle. **Figure 3.1.**

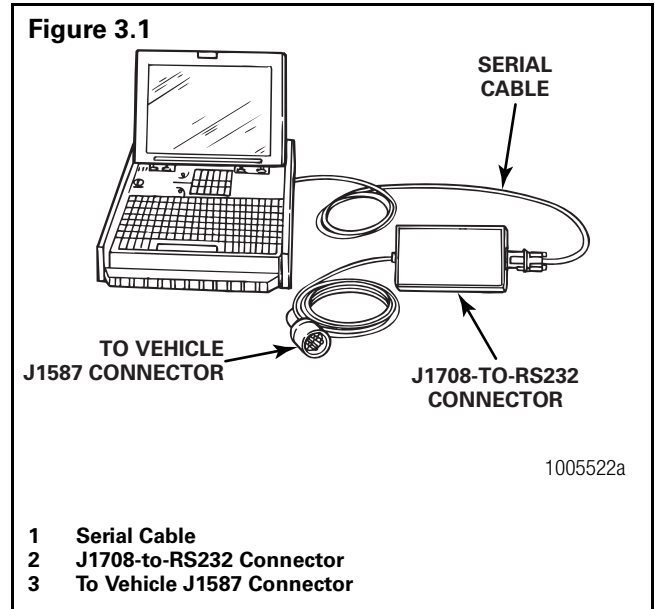

2. Select TOOLBOX Software from Desktop or from the Windows Start Menu to display the TOOLBOX Main Menu. **Figure 3.2.**

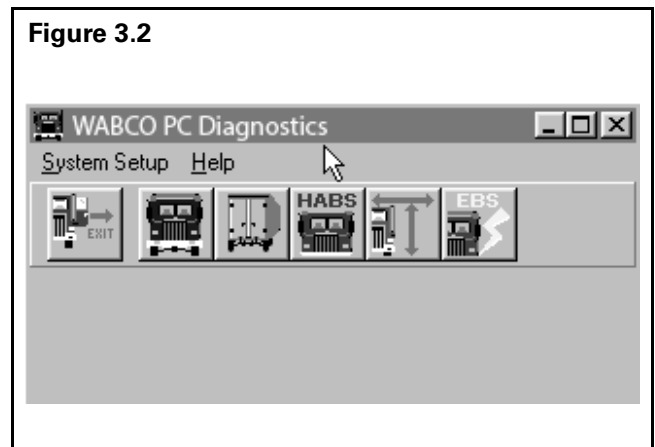

Section 3 Troubleshooting & Testing

- From the **Main Menu**, select **Tractor ABS Diagnostics**, or use the pull down menu to make your selection. **Figure 3.3**. The **ABS Main Screen** will appear. **Figure 3.4**.

Figure 3.3

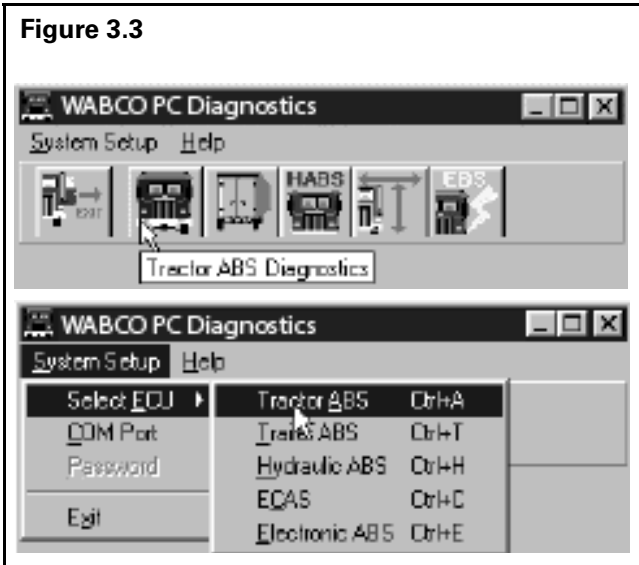
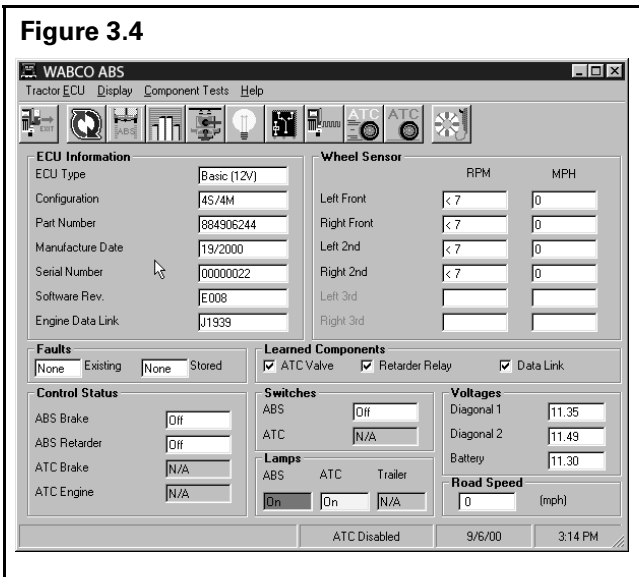

Figure 3.4



- From the **ABS Main Screen**, select the **Faults** icon, or use the pull down menu to display the faults from the ECU. **Figure 3.5**.

NOTE: If there are **Faults** in the system (**YES** in existing or stores fields) double-click on the **YES** to display **Fault Information**.

Figure 3.5

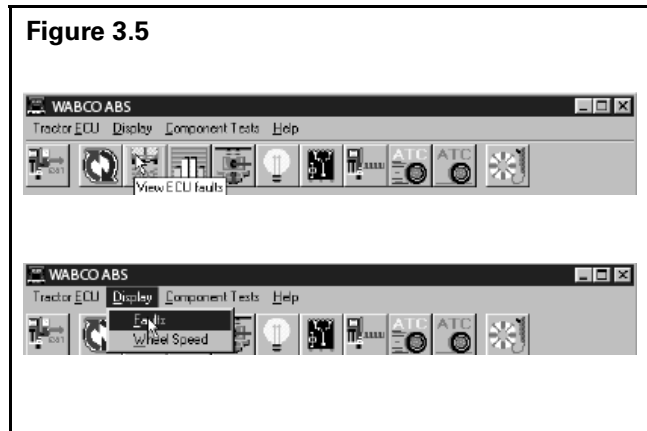

- The **Fault Information Screen** contains a description of the fault. Repair instructions for each fault appear at the bottom of the screen. **Figure 3.6**.

Figure 3.6

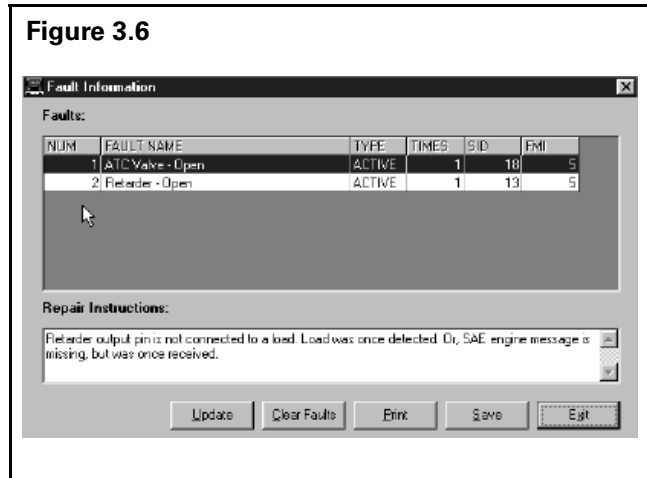

NOTE: Faults that occur after the screen is displayed will not appear until a screen update is requested. Use the **Update** button at the bottom of the screen to refresh the fault information table.

- After making the necessary repairs, use the **Clear Faults** button at the bottom of the screen to clear the fault. Use the **Update** button to refresh the fault information table and display the new list of faults.

Blink Code Diagnostics

Definitions

Before using blink code diagnostics, you should be familiar with a few basic terms. If you used previous versions of WABCO's blink code diagnostics, review these definitions to identify major changes.

ABS Indicator Lamp: This lamp serves two purposes: it alerts drivers to an ABS fault and it is used during diagnostics to display the blink code.

Blink Code: A series of blinks or flashes that describe a particular ABS system fault or condition.

Blink Code Cycle: Two sets of flashes with each set separated by a one-and-one-half second pause. Blink codes are defined in Blink Code Identification in this section.

Blink Code Switch: A momentary switch that activates blink code diagnostic capabilities. Switch types and locations vary, depending on the make and model of the vehicle.

Clear: The process of erasing faults from the ECU.

Diagnostics: The process of using blink codes to determine ABS system faults.

Fault: An ABS malfunction detected and stored in memory by the WABCO ECU. System faults may be **Active** or **Stored**.

Active Fault: A condition that **currently exists** in the ABS system; for example, a sensor circuit malfunction on the left front steering axle. An active fault must be repaired before it can be cleared from memory — and before you can display additional blink code faults.

Stored Fault: There are two types of stored faults:

- A. A repaired active fault that **has not been cleared** from the ECU.
- B. A fault that occurred but **no longer exists**. For example, a loose wire that makes intermittent contact. Because stored faults are not currently active they do not have to be repaired before they can be cleared from memory.

WABCO recommends you keep a record of these faults for future reference.

System Configuration Code: One digit code displayed during the clear mode. Blink codes for common ABS system configurations are shown in **Figure 3.7**.

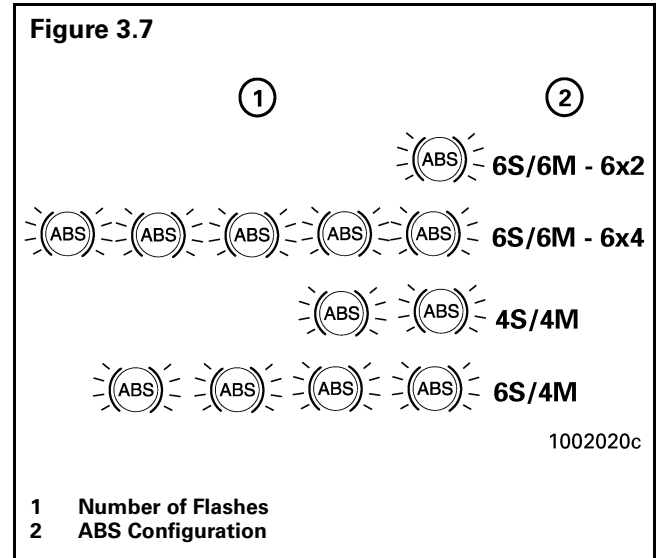

Diagnostic Mode

To enter the diagnostic mode, press and hold the blink code switch for one second, then release.

Clear Mode

To erase faults from the ECU, you must be in the clear mode. To enter the clear mode, press and hold the blink code switch for at least three seconds, then release.

If the system displays eight quick flashes followed by a system configuration code, the clear was successful. Stored ABS faults have been cleared from memory.

If you do not receive eight flashes, there are still active faults that must be repaired before they can be cleared.

Section 3 Troubleshooting & Testing

Blink Code Diagnostics

| Troubleshooting with Blink Code Diagnostics | | | |
|---|---|---|---|
| Mode | Procedure | System Response | Action |
| DIAGNOSTIC | Step I. Turn Ignition ON . | Possible responses: A. ABS indicator lamp comes on momentarily then goes out, indicating System O.K. B. ABS indicator lamp does not light, indicating possible wiring fault or burned-out bulb. C. ABS indicator lamp stays on, indicating: <ul style="list-style-type: none"> • Fault, or faults, in the system. • Sensor fault during last operation. • Faults cleared from ECU, but vehicle not driven. • ECU disconnected. | No recognizable active faults in the ABS. No action required. Inspect wiring. Inspect bulb. Make necessary repairs. Continue with blink code diagnostics. (Go to Step II.) Continue with blink code diagnostics. (Go to Step II.) Drive vehicle — lamp will go out when vehicle reaches 4 mph (6 km/h). Connect ECU. |
| | Step II. Press and hold Blink Code Switch for one second, then release. | ABS indicator lamp begins flashing two-digit blink code(s). | Determine if fault is active or stored: Active Fault: Lamp will repeatedly display one code. Stored Fault: Lamp will display code for each stored fault then stop blinking. Faults will be displayed one time only . |
| | Step III. Count the flashes to determine the blink code. | First Digit: 1 - 8 flashes, Pause (1-1/2 seconds). Second Digit: 1 - 6 flashes, Pause (4 seconds). | Find definition for blink code on blink code chart. |
| | Step IV. Turn Ignition OFF . Repair and Record faults. | Active Fault. Stored Faults. | Make the necessary repairs. Repeat Steps I, II, and III until System O.K. code (1-1) received. Record for future reference. NOTE: Last fault stored is first fault displayed. |
| CLEAR | Step V. Turn Ignition ON . Clear Faults from memory: Press and hold blink code switch for at least three seconds, then release. | ABS Indicator Lamp flashes eight times. Eight flashes not received. | All stored faults successfully cleared. Turn ignition OFF . Active faults still exist, repeat Steps I through V. |

Blink Codes Illustrated

Figure 3.8

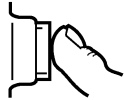

1 Second Hold

Active Fault

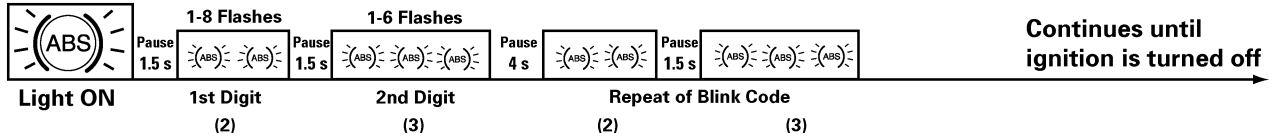

Example:
Blink Code 2-3: Fault in ABS modulator valve, right rear drive axle.



1 Second Hold

Stored Faults

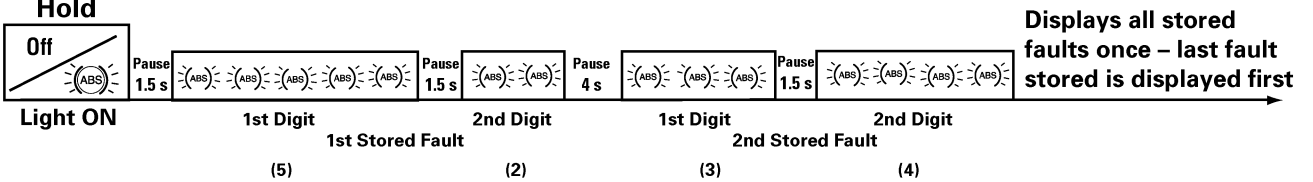

Example:
Blink Code 5-2: Sensor signal erratic, left front steer axle.
3-4: Too much sensor gap, left rear drive axle.



1 Second Hold

System O.K.

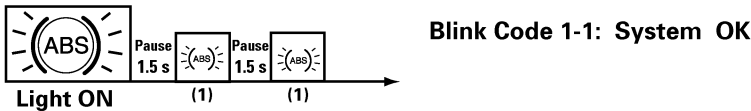

S = Seconds

1002021b

Continued on next page.

Blink Codes Illustrated (Continued)

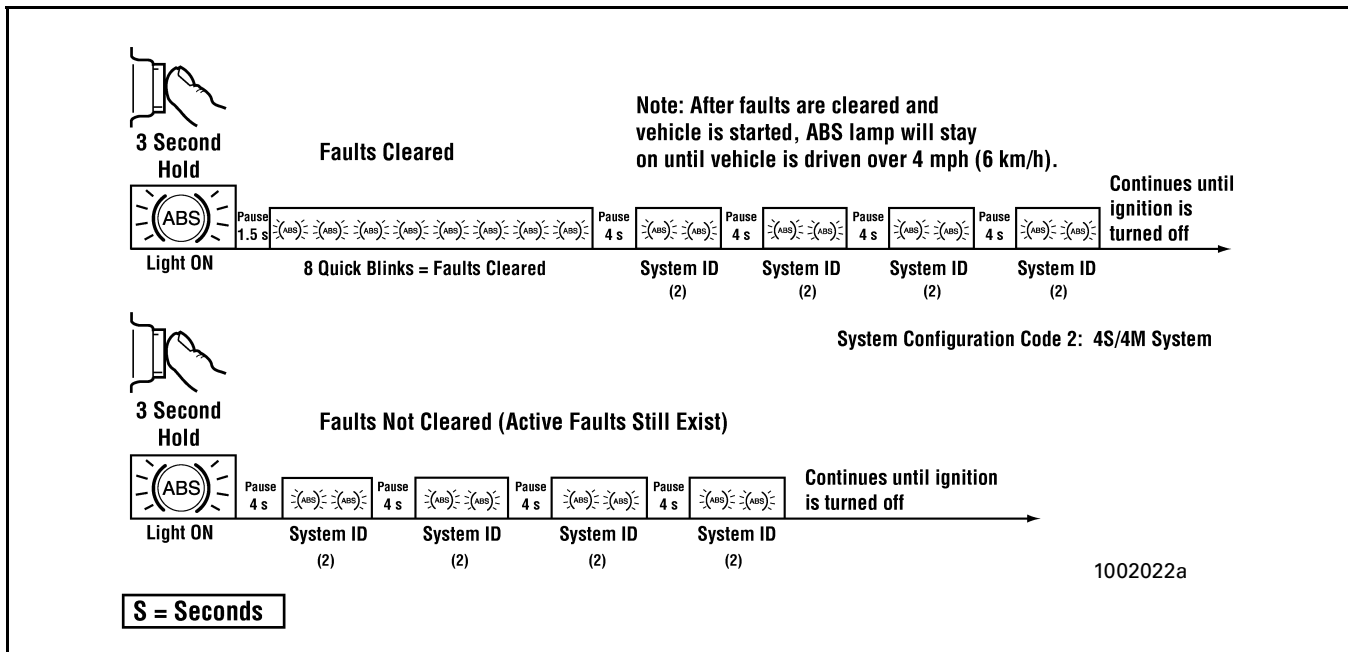

Working with Blink Codes

Blink Code Conditions

When using blink code diagnostics, the following conditions could occur:

| Blink Code Conditions | | |
|--|--|--|
| Condition | Reason | Action |
| ABS indicator lamp does not come on at ignition. | Loose or burned-out bulb. | Check bulb. Check connections. Make necessary repairs. |
| | Voltage not within acceptable range (9.5-14 volts for a 12-volt system, 18-30 volts for a 24-volt system). | Check connections. Measure voltage. Make necessary repairs. |
| Can't use blink code diagnostics; ABS indicator lamp will not go off when blink code is activated. | Switch not held for proper length of time: 1 Second — Diagnostics Mode 3 Seconds — Clear All Mode | Repeat procedure, hold switch for proper length of time. |
| | Improper or faulty wiring. | Inspect and repair wiring. |
| Eight Flashes not received after blink code switch pressed for at least three seconds, then released. | Active Faults still exist. | Identify active faults, then make necessary repairs. Turn ignition OFF, then repeat Blink Code Diagnostics. |

Blink Code Identification

Use the following information to identify the blink code:

| Blink Code Identification | |
|---|---|
| First Digit (Type of Fault) | Second Digit — Specific Location of Fault |
| 1 No faults | 1 No Faults |
| 2 ABS modulator valve 3 Too much sensor gap 4 Sensor short or open 5 Sensor signal erratic 6 Tooth wheel | 1 Right front steer axle (curb side) 2 Left front steer axle (driver's side) 3 Right rear drive axle (curb side) 4 Left rear drive axle (driver's side) 5 Right rear/additional axle (curb side)* 6 Left rear/additional axle (driver's side)* |
| 7 System function** | 1 J1922 or J1939 datalink 2 ATC valve 3 Retarder relay (third brake) 4 ABS indicator lamp 5 ATC configuration 6 Reserved for future use |
| 8 ECU | 1 Low power supply 2 High power supply 3 Internal fault 4 System configuration error 5 Ground |

* Tandem, lift, tag or pusher axle depending upon the type of suspension.

** If this code continues after all repairs have been made — or if you receive a code for a component that is not installed on the vehicle — it may be necessary to reconfigure the ECU. Contact WABCO North America Customer Care at 855-228-3203 for reconfiguration information.

Section 3 Troubleshooting & Testing

WABCO







Blink Code Troubleshooting and Repair

| Blink Code | Action Required | Reference |
|-------------------------------|---|---|
| 2-1 2-4 2-2 2-5 2-3 2-6 | Check ABS modulator valve, valve cable, and connectors. 12-volt system: Verify 4.0-9.0 ohms resistance (ABS modulator valve). 24-volt system: Verify 11.0-21.0 ohms resistance (ABS modulator valve). | Refer to "Valve Tests," page 30. |
| 3-1 3-4 3-2 3-5 3-3 3-6 | Adjust wheel sensor to touch tooth wheel. Check sensor gap. Check for loose wheel bearings or excessive hub runout. Verify minimum 0.2 volts AC output @ 30 RPM. | Refer to "Sensor Adjustment," page 29, "Sensor Output Voltage Test," page 29, and "Component Tests," page 24. |
| 4-1 4-4 4-2 4-5 4-3 4-6 | Check sensor, sensor cable, and connectors. Verify 900-2000 ohms resistance. | Repair or replace as needed. |
| 5-1 5-4 5-2 5-5 5-3 5-6 | Check for tire size mismatch or tooth wheel difference. Check sensor, sensor cable, and connector for intermittent contact. | Refer to "Tire Size Range," page 28. |
| 6-1 6-4 6-2 6-5 6-3 6-6 | Check for damaged tooth wheel. | Repair or replace as needed. |
| 7-1* | Check for proper data link connection (J1922 and J1939). Verify wheel spin on each axle. | Refer to wiring diagram in Appendix II. |
| 7-2* | Check ATC Valve, valve cables, and connectors. Verify 7 to 14 ohms resistance for a 12-volt system, 28-49 ohms resistance for a 24-volt system. | Refer to "Valve Tests," page 30. |
| 7-3* | Check retarder (third brake) connections. | Refer to wiring diagram in Appendix II. |
| 7-4* | Check ABS indicator light connections. Verify blink code switch was activated longer than 16 seconds. | |
| 7-5* | Verify proper ATC set-up. | Verify engine datalink connection. |
| 7-6* | Verify accuracy of blink code and clear from ECU memory. | Refer to "Blink Code Diagnostics," page 16. |
| 8-1 | Check for low voltage. Check vehicle voltage, fuse, and supply to ECU (9.5-14 volts). | Refer to wiring diagram in Appendix II and "Voltage Check," page 28. |
| 8-2 | Check for high voltage. Check vehicle voltage (9.5-14 volts for a 12-volt system, 18-30 volts for a 24-volt system). Verify accuracy of blink code and clear from ECU memory. | Refer to "Voltage Check," page 28, and "Blink Code Diagnostics," page 16. |
| 8-3 | Verify accuracy of blink code and clear from ECU memory. | Refer to "Blink Code Diagnostics," and "Clear Mode," page 15. |
| 8-4 | Verify all ECU connectors are in place. Verify accuracy of blink code and clear from ECU memory. <i>If code does not clear, it may be necessary to replace the ECU.</i> | Contact WABCO North America Customer Care at 855-228-3203. |
| 8-5 | (Full function, cab-mounted only) Check all ABS valve ground connections for diagonals 1 and 2 (open, shorted to ground or shorted to battery). | Refer to wiring diagram in Appendix II. |

* If this code continues after all repairs have been made — or if you receive a code for a component that is not installed on the vehicle — it may be necessary to reconfigure the ECU. Contact WABCO North America Customer Care at 855-228-3203 for reconfiguration information.

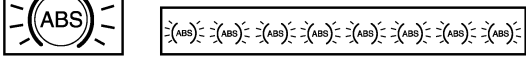
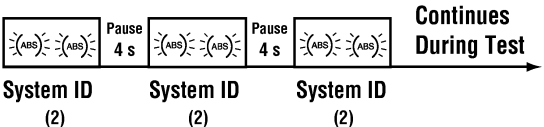
J1922 or J1939 Datalink Verification

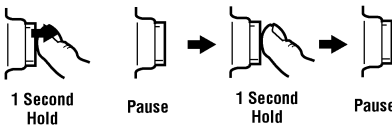
The Pro-Link diagnostic tool provides the easiest way to verify the J1922 or J1939 datalink connection. If you do not have a Pro-Link, you can use the blink code switch to verify this connection.

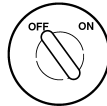
| | |
|---|---|
| <p>1. Turn ignition ON. Press blink code switch — hold for 3 seconds.</p> <p>A. ATC indicator lamp will come on and stay on for the entire test. <i>If vehicle is not equipped with ATC, the ATC indicator lamp will not come on.</i></p> <p>B. ABS indicator lamp will come on and blink 8 times. <i>If the lamp does not blink 8 times, there are faults that must be cleared before you continue with this test.</i></p> <p>C. The eight quick flashes will be followed by the system configuration code. A 4S/4M (2 blinks) system is identified here. <i>The system configuration code will continue during the entire test.</i></p> <p>2. Activate the J1922 or J1939 engine torque reduction code, as follows:</p> <p>A. Step on the accelerator. Bring the engine to 1000 RPM. <i>Leave your foot on the accelerator during the entire test.</i></p> <p>B. While engine is at 1000 RPM, press the blink code switch twice, as follows: Press for one second Release for one second Press for one second Release for one second</p> <p>C. The engine will go to idle for approximately 10 seconds and then return to 1000 RPM.</p> <p>3. Turn ignition OFF. Test complete, engine torque reduction command verified.</p> | <p>1.</p> <p></p> <p>A. </p> <p>B.  8 Quick Blinks = Faults Cleared</p> <p>C. </p> <p>2.</p> <p>A. </p> <p>B. </p> <p>C. </p> <p>3. </p> |
|---|---|

Component Tests and Functions

TOOLBOX Software

NOTE: Refer to page 22 of this manual for instructions for running TOOLBOX Software, or refer to the Software Owner’s Manual, TP-99102, for complete instructions.

Use TOOLBOX Software to display wheel speeds, cycle ABS valves, activate ABS and ATC lamps, including the trailer ABS lamp, and turn the retarder relay on or off. In addition, the J1939 engine datalink connection may be quickly verified by using TOOLBOX Software.

Wheel Speed

Select the wheel speed icon or use the pull down menu from the ABS Main Screen to display wheel speed data in both numeric and graphical form. This data may be shown in RPM or MPH format (Figure 3.9) and in vertical or horizontal graphs (Figure 3.10 and Figure 3.11). Select the appearance and style from the options menu.

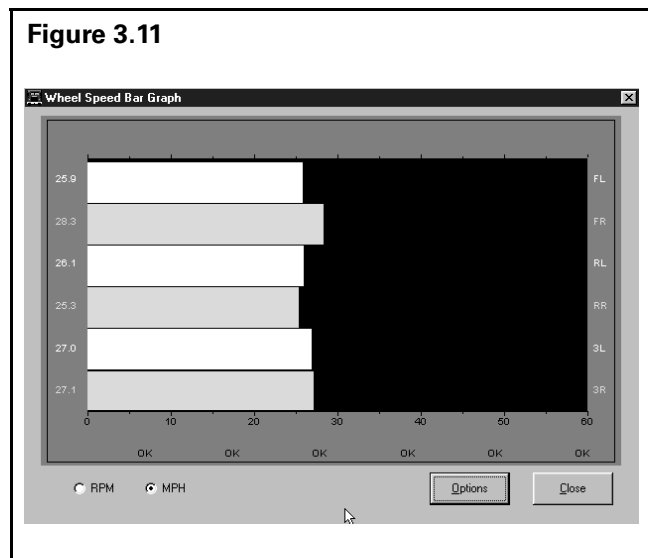
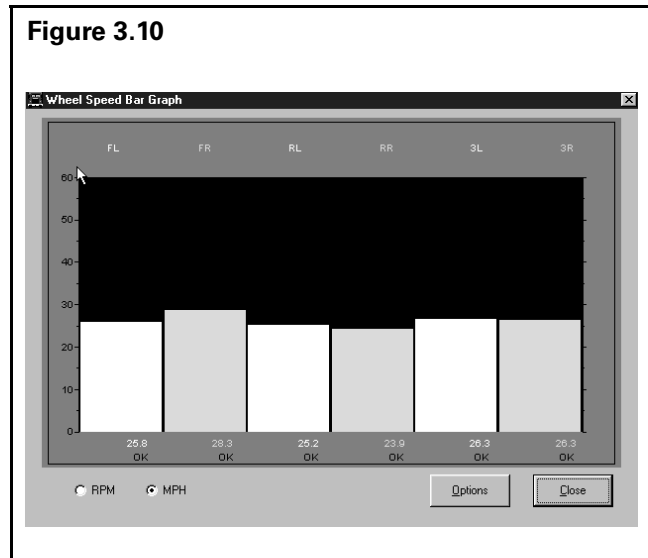
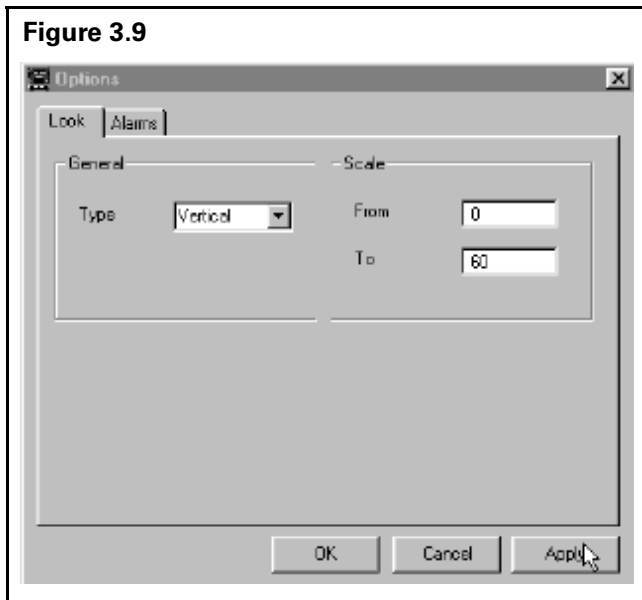

Valve Activation

Select the valve icon or use the pull down menu to select and cycle individual ABS valves. Then listen to ensure the correct valve is cycling. This is helpful when verifying proper operation, installation and wiring. **Figure 3.12.**

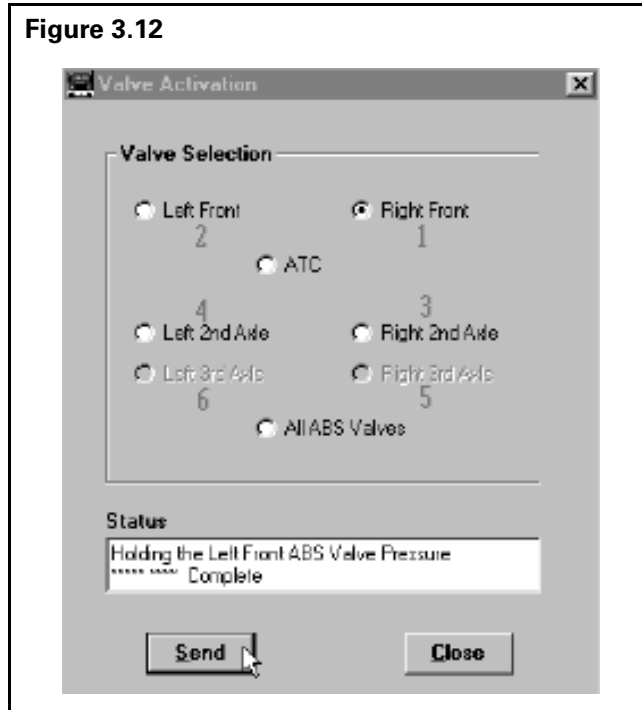

Lamp Activation

Select the lamp icon or use the pull down menu to turn the tractor and trailer ABS and/or the ATC (wheel spin) lamps on or off. This is helpful when verifying proper operation, installation and wiring of the lamps to the ECU. **Figure 3.13.**

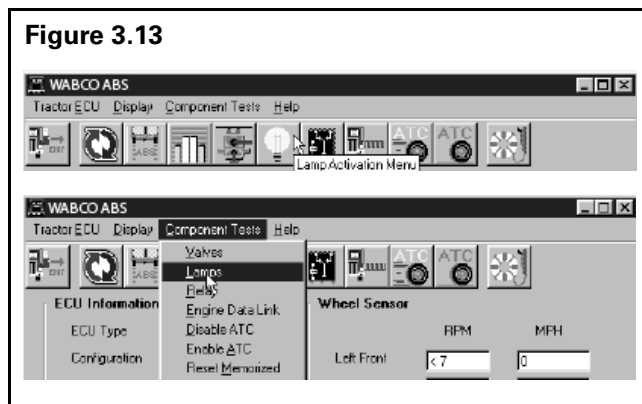

Data Link Activation

Select the **Engine Data Link** icon from the Main ABS Screen or use the pull down menu to send a “limit engine torque” command to the engine or a “disable retarder” command to the retarder. **Figure 3.14.**

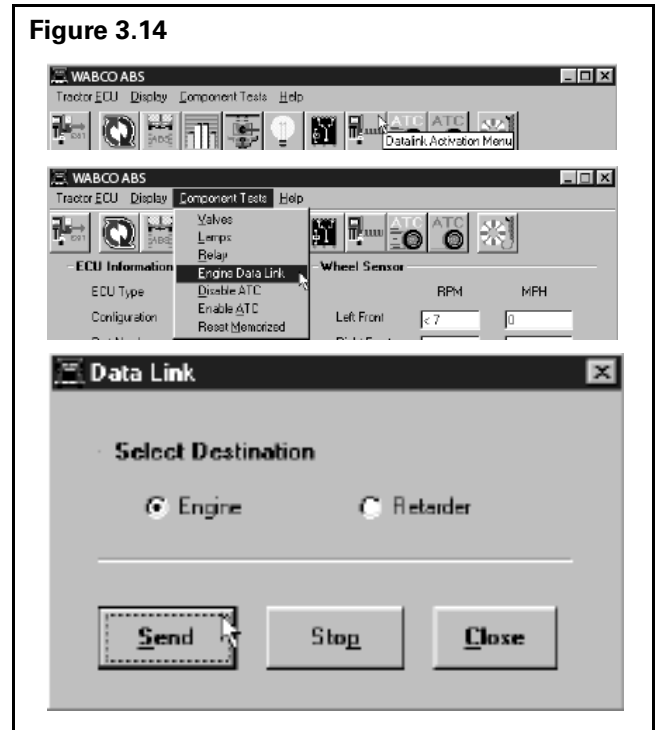

Disable or Enable ATC

Select the **Disable ATC** icon or use the pull down menu on the **ABS Main Screen** to send the command to the ECU to disable automatic traction control. ATC will remain disabled until the enable command is sent — or until the vehicle ignition is cycled. **Always disable ATC for dynamometer testing.** **Figure 3.15.**

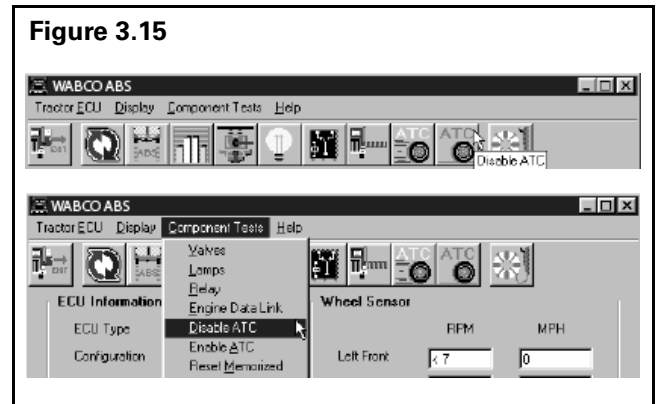

Section 3 Troubleshooting & Testing

WABCO

Select the **Enable ATC** icon or use the pull down menu on the ABS Main Screen to send a command to the ECU to enable ATC. This is the normal state of the ECU. **Figure 3.16.**

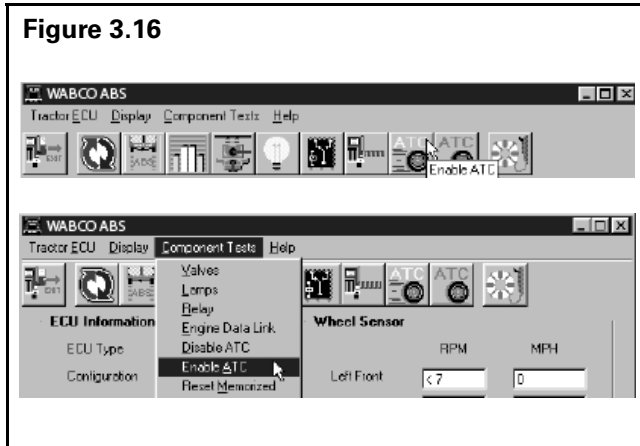

NOTE: The status bar on the **ABS Main Screen** reflects the current status of the ATC function; enabled, disabled or N/A (not available).

MPSI Pro-Link 9000

NOTE: You must use the D version cartridge, 4.0 or higher, with D version ECUs.

Use the Pro-Link 9000 to:

- Diagnose system faults on ABS or ABS/ATC systems.
- Perform component measurement and function tests.

NOTE: The Pro-Link 9000 may be used in place of blink code diagnostic procedures.

The Pro-Link screens illustrated appear with D version ECUs. Refer to Maintenance Manual 28 if you are using the Pro-Link with C version ECUs.

Component Tests

Components that may be tested with the Pro-Link® 9000 are:

- Vehicle Voltages
- ABS Modulator Valves
- ATC Valves
- ABS/ATC Indicator Lamps
- Sensors
- Engine Datalink
- Retarder Relay
- Retarder Datalink
- ABS/ATC Switches

Diagnostic and Testing Procedure

1. Slide the WABCO D version cartridge into the Pro-Link keypad until the connection is tight. **Figure 3.17.**
2. Chock the wheels, apply the parking brake, and make sure ignition power is off.
3. Locate the 6-pin diagnostic receptacle in the vehicle cab. Insert the 6-pin connector from the Pro-Link into the receptacle.

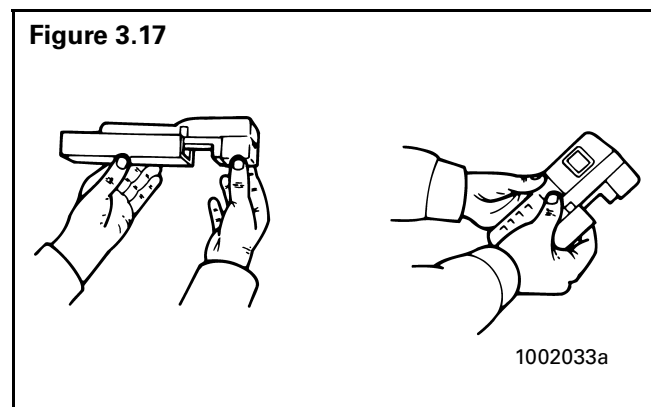

- Turn the ignition to the ON/RUN position. The Pro-Link screen should power up.

If the Pro-Link does not power up, or if the screen indicates NO DATA RECEIVED:

- Check connections.
- Make sure the cartridge is properly connected to the Pro-Link keypad.
- Verify 9.5-14 volts (12-volt system) or 18-30 volts (24-volt system) DC power and ground at the connector and ABS ECU.
- Check the fuse panel for a blown fuse.
- Check for proper wiring in the diagnostic connector.

- Refer to the Pro-Link manual for complete diagnostic and testing instructions.

The Pro-Link 9000 is available from Kent-Moore, 800-328-6657.

Pro-Link Screens

This information provides basic screen explanations for the Pro-Link 9000 with a WABCO D version cartridge. For complete operating instructions and test information, refer to the Pro-Link manual.

The most commonly used types of screens are the **Fault Information** screens, and the **Component Test** screens.

Fault Information Screens:

Existing Faults: Use these screens to identify existing faults. The Pro-Link screen displays a written description of the fault, including the location on the vehicle where each exists. As long as there is an active (existing) fault in the system, the Pro-Link will not let you clear faults.

Stored Faults: Use these screens to identify faults stored in the ECU memory. Stored faults may be existing faults that have been repaired, or faults that existed for a short time, then corrected themselves. After displaying the stored faults, the Pro-Link lets you erase them from memory. All stored faults are cleared at one time.

Pro-Link Display

Depending upon the ECU being tested, the Pro-Link screen will display certain options or components only when recognized by the ECU. These include:

- ATC, ATC Indicator Lamps, ATC Valve
- Engine Datalink
- Retarder Relay
- Retarder Datalink

Using the Pro-Link

The following illustrates a typical fault screen sequence:

- A 4S/4M ABS/ATC system
- Where the ECU detected an SAE J1922 Datalink
- With one stored fault

| | |
|--------------------------|---------------|
| TRACTOR 4S/4M ATC | |
| DATA LINK | J1922* |
| EXISTING FAULT | YES |
| STORED FAULTS | YES |

* With some ECUs, this line will not appear.

Press Arrow Down Key

| | |
|------------------------|--------------|
| DATA LINK | J1922 |
| EXISTING FAULT | YES |
| STORED FAULTS | YES |
| [FUNC] FOR MENU | |

Press FUNC to display menu.

Select Existing Fault to display active fault.

| | |
|-----------------------------|-------------------------|
| TRACTOR ABS/ATC MENU | |
| – SELECTIONS – | |
| ↑ | EXISTING FAULT ↓ |

Section 3 Troubleshooting & Testing

Press ENTER to select. The following screen appears.

The first line displays the number of existing faults (1 of 1), the blink code (2-3), and the number of times the fault occurred (1 time). Lines two and three provide a written description of the fault.

| | | |
|----------------------|--------|----|
| 1 of 1 | (2, 3) | 1X |
| R REAR ABS VALVE | | |
| OPEN OR CABLE DAMAGE | | |
| ↑ | | ↓ |

Press FUNC to exit. The following screen appears.

Remove power from the ECU, make necessary repairs, and recycle ECU.

| |
|-------------------|
| TURN IGNITION OFF |
| REPAIR EXISTING |
| FAULT |
| [FUNC] TO EXIT |

Press FUNC to return to Tractor ABS/ATC menu.

| |
|----------------------|
| TRACTOR ABS/ATC MENU |
| – SELECTIONS – |
| ↑ STORED FAULTS ↓ |

Press ENTER to display stored faults.

A description of the stored fault appears. In this example, only one fault is stored in memory, as indicated on line one. Blink code and number of times the fault occurred also appear on line one. Lines two and three provide a written description of the fault.

| | | |
|----------------------|--------|----|
| 1 of 1 | (2, 3) | 1X |
| R REAR ABS VALVE | | |
| OPEN OR CABLE DAMAGE | | |
| ↑ | | ↓ |

Press FUNC to exit. The following screen appears if you try to clear a stored code with an existing fault present.

Remove power from the ECU, make necessary repairs, and recycle ECU.

| |
|---------------------|
| CANNOT ERASE STORED |
| FAULTS. REPAIR |
| EXISTING FAULT(S) |
| [ENTER] TO CONTINUE |

Clearing Stored Faults

The screens you will see when clearing faults are illustrated below.

| | |
|-------------------|--------|
| TRACTOR 4S/4M ATC | |
| DATA LINK | J1922* |
| EXISTING FAULT | NO |
| STORED FAULTS | YES |

* With some ECUs, this line will not appear.

Press Arrow Down Key.

| | |
|-----------------|-------|
| DATA LINK | J1922 |
| EXISTING FAULT | NO |
| STORED FAULTS | YES |
| [FUNC] FOR MENU | |

There are no existing faults. Select stored faults to view and clear memory.

Press FUNC to display menu.

Select Stored Faults.

| |
|----------------------|
| TRACTOR ABS/ATC MENU |
| – SELECTIONS – |
| ↑ STORED FAULTS ↓ |

Press ENTER to display stored faults.

Pro-Link displays number, blink code, number of occurrences, and written description of stored faults.

| | | |
|----------------------|--------|----|
| 1 of 1 | (2, 3) | 2X |
| R REAR ABS VALVE | | |
| OPEN OR CABLE DAMAGE | | |
| ↑ | | ↓ |

Press FUNC. The following screen will appear:

| |
|-----------------|
| CLEAR ALL |
| STORED FAULT(S) |
| CLEAR Y ← → [N] |

Use arrow key to move to Y (yes) to clear all stored faults at once.

| |
|-----------------|
| CLEARING |
| STORED FAULT(S) |

When faults are cleared, Pro-Link screen will prompt you to continue.

| |
|---------------------|
| STORED FAULT(S) |
| CLEARED |
| [ENTER] TO CONTINUE |

Press ENTER to return to ABS/ATC menu.

Component Test Screens

These screens help you test ABS components. Select this function from the Tractor ABS/ATC menu.

| |
|----------------------|
| TRACTOR COMP TESTS |
| – SELECTIONS – |
| ↑ VEHICLE VOLTAGES ↓ |

- ABS VALVES
- ATC
- ABS INDICATOR LAMP
- ATC INDICATOR LAMP
- ABS/ATC SWITCHES
- SENSORS
- ENGINE DATALINK
- RETARDER RELAY
- RETARDER DATALINK

Select the appropriate function. Each screen has instructions to guide you through the test. Refer to the Pro-Link Manual for complete instructions.

System Information

With some ECUs, the Pro-Link will display system information — components or options supported by the ECU. Access these screens through System Setup (main ABS menu).

The following screens illustrate:

- A 4S/4M ABS/ATC system
- Where the ECU has not recognized a retarder relay
- Where the ECU has recognized a J1922 or J1939 datalink
- The ECU is capable of supporting ABS and ATC switches (these may not be installed on the vehicle)

| | |
|--------------------|---|
| TRACTOR ABS/ATC | |
| SYSTEM INFORMATION | |
| SENSORS | 4 |
| MODULATORS | 4 |

| | |
|----------------|-----|
| ATC VALVE | YES |
| RETARDER RELAY | NO |
| J1922 | YES |
| J1939 | NO |
| DIFF LOCK | NO |
| ABS SWITCH | YES |
| ATC SWITCH | YES |

NOTE: Yes indicates the ECU is capable of supporting these options. These may or may not be installed on the vehicle.

Section 3 Troubleshooting & Testing

The following definitions explain the function of each test.

| Component Test | Function |
|-------------------|--|
| Vehicle Voltages | Monitors the voltage signals powering the ECU. |
| ABS Valves | Cycles the valves, one at a time. With brake pedal applied, you should hear four short air exhausts, then one long air pressure hold. A menu selection lets you choose from four or six valves. This test is used to verify valve locations and proper wiring. NOTE: The treadle must be applied to pressurize the brake chambers. |
| ATC | Checks the ATC valve. You will hear a click as the valve cycles. NOTE: The Pro-Link may be used to shut off ATC for dynamometer testing. |
| ABS Lamp | Monitors the commanded (on/off) states of the ABS lamp. Follow the screen prompts (1 On, 2 Off) to change the status of the lamp on the instrument panel. |
| ATC Lamp | Monitors the commanded (on/off) states of the ATC lamp. Follow the screen prompts (1 On, 2 Off) to change the status of the lamp on the instrument panel. |
| ABS/ATC Switches | Checks the status of ABS and ATC/Deep Snow and Mud switches on the instrument panel. |
| Sensors | Monitors the input to the ECU from the wheel. Vehicle must be stationary and wheels must be rotated during this test. |
| Engine Datalink | Checks wiring connections and response between the engine and the ECU. |
| Retarder Relay | Activates the relay to verify function (a click will be heard). This test also checks wiring connections. |
| Retarder Datalink | Checks wiring connections and retarder response between the retarder and the ECU. |

Tire Size Range

For proper ABS/ATC operation with the standard ECU, front and rear tire sizes must be within $\pm 14\%$ of each other. When this tire size range is exceeded without electronically modifying the ECU, the system performance can be affected and the indicator lamp can illuminate.

Call WABCO North America Customer Care at 855-228-3203 if you plan a tire size difference greater than 14%.

Calculate the tire size with the following equation:

$$\% \text{ Difference} = \left\{ \frac{\text{RPM Steer}}{\text{RPM Drive}} - 1 \right\} \times 100$$

RPM – tire revolutions per mile

Testing Components



CAUTION

When troubleshooting and testing the ABS system, do not damage the connector terminals.

Voltage Check

Measure voltage at the pins indicated in **Table A**.

- Voltage must be between 9.5 and 14 volts for a 12-volt system (18 and 30 for a 24-volt system).
- The ignition must be turned ON for this test.

Table A: Voltage Check Pins

| ECU | Connector | Pins |
|---------------|-----------|----------------------------------|
| Cab-Mounted | 18-Pin | 7 and 10 8 and 11 9 and 12 |
| Basic | 15-Pin | 7 and 4 8 and 9 |
| Frame-Mounted | X1-Grey | 1 and 12 2 and 11 |

Location of Sensors

On steering axles, the sensor is accessible on the in-board side of the steering knuckle.

On drive axles, the drum assembly may have to be pulled to gain access to the sensor.

Sensor Adjustment

- Push the sensor in until it contacts the tooth wheel.
- Do not pry or push sensors with sharp objects.
- Sensors will self-adjust during wheel rotation.

Sensor Output Voltage Test

Voltage must be at least 0.2 volts AC at 30 rpm.

1. Turn ignition OFF.
2. Disconnect the appropriate connector from the ECU (refer to wiring diagram).
3. Rotate wheel by hand at 30 rpm (1/2 revolution per second).
4. Measure voltage at the pins indicated in **Table B**.
 - If the minimum output voltage is less than 0.2, push the sensor toward the tooth wheel, then repeat the measurement.

Table B: Sensor Check Pins

| ECU | Sensor | Connector | Pins |
|---------------|---------------|------------|-----------|
| Cab-Mounted | LF | 6-Pin | 4 and 5 |
| | RF | 9-Pin | 4 and 5 |
| | LR | 15-Pin | 5 and 6 |
| | RR | 15-Pin | 8 and 9 |
| | LR (3rd Axle) | 12-Pin | 5 and 6 |
| | RR (3rd Axle) | 12-Pin | 8 and 9 |
| Basic | LF | 18-Pin | 12 and 15 |
| | RF | 18-Pin | 10 and 13 |
| | LR | 18-Pin | 11 and 14 |
| | RR | 18-Pin | 17 and 18 |
| Frame-Mounted | LF | X2 – Black | 7 and 8 |
| | RF | X2 – Black | 5 and 6 |
| | LR | X3 – Green | 1 and 2 |
| | RR | X3 – Green | 3 and 4 |
| | LR (3rd Axle) | X4 – Brown | 3 and 4 |
| | RR (3rd Axle) | X4 – Brown | 5 and 6 |

Sensor Resistance

The sensor circuit resistance must be 900-2000 ohms. Resistance can be measured at the sensor connector, or at the pins on the ECU connector. To measure resistance:

1. Turn ignition OFF.
2. To measure resistance at the sensor connector, disconnect the ECU connector from the ECU. To measure resistance at the sensor connector, disconnect the sensor from the sensor extension cable.
3. Measure output at the pins indicated in **Table B**.

Dynamometer Testing Vehicles with ATC



WARNING

Failure to disable the ATC before dynamometer testing could result in serious personal injury and damage to the vehicle.

Vehicles with ATC must have the ATC disabled to test the vehicle on a dynamometer. To disable the ATC, press and hold the blink code switch for at least three seconds. Once the system configuration code begins, ATC has been disabled. The ATC lamp comes on and stays on while ATC is disabled.

NOTE: Removing the ABS circuit breaker/fuse or removing the ECU power connector will also disable ABS and ATC or you may use the Pro-Link to disable ATC.

Valve Tests

ABS Modulator Valve

Measure resistance across each valve solenoid coil terminal and ground on the ABS valve to ensure 4.0 to 9.0 ohms for a 12-volt system (11.0 to 21.0 ohms for a 24-volt system). **Figure 3.18.**

- If the resistance is greater than 9.0 ohms for a 12-volt system (21.0 ohms for a 24-volt system), clean the electrical contacts in the solenoid. Check the resistance again.
- To check the cable and the ABS valve as one unit, measure resistance across the pins on the ECU connector of the harness. Check the diagram of the system you are testing for pin numbers. (Refer to Appendix II.)

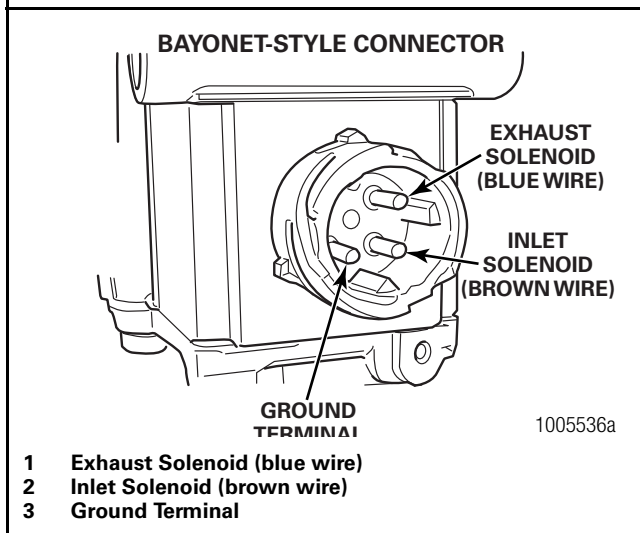
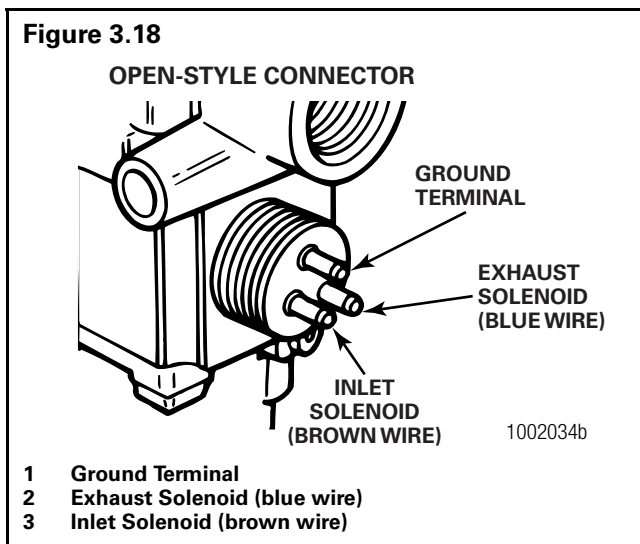

ATC Valve

Measure resistance across the two electrical terminals on the ATC valve to ensure 7.0 to 14.0 ohms for a 12-volt system (26.3 to 49.0 ohms for a 24-volt system). **Figure 3.19.**

- If the resistance is greater than 14.0 ohms for a 12-volt system (49.0 ohms for a 24-volt system), clean the electrical contacts on the solenoid. Check the resistance again.
- To check the cable and ATC valve as one unit, measure resistance across the pins on the ECU connector of the harness. Check the diagram of the system you are testing for pin numbers. (Refer to Appendix II.)

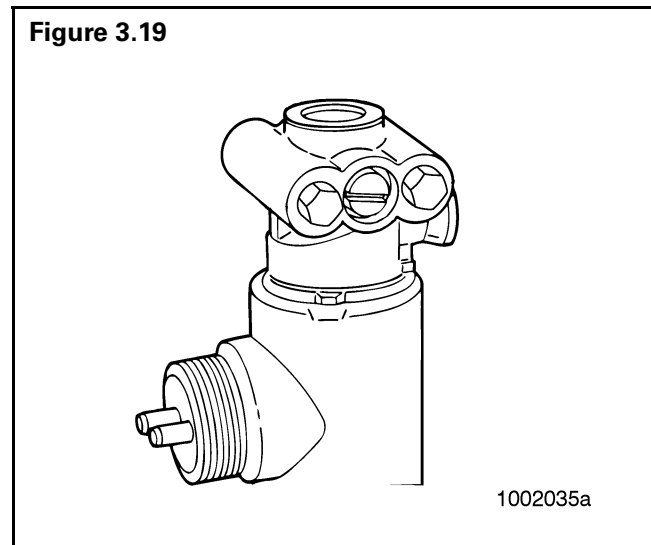

NOTE: Refer to Appendix III for ABS Valve Package Troubleshooting Guide.

Component Removal and Installation

Valves

- ABS Modulator Valves
- ATC Valve
- ABS Valve Package (Front or Rear)
 - Modulator Valves
 - Relay Valve or Quick Disconnect Valve
 - ATC Valve

Sensor Lube Specification

WABCO specifications call for a sensor lubricant with the following characteristics:

Lube must be mineral oil-based and contain molydisulfide. It should have excellent anti-corrosion and adhesion characteristics, and be capable of continuous function in a temperature range of -40° to 300°F (-40° to 150°C).

! WARNING

To prevent serious eye injury, always wear safe eye protection when you perform vehicle maintenance or service.

Release all air from the air systems before you remove any components. Pressurized air can cause serious personal injury.

! CAUTION

Use the following procedures to avoid damage to the electrical system and ABS/ATC components.

When welding on an ABS- or ABS/ATC-equipped vehicle is necessary, disconnect the power connector from the ECU.

Sensors

Wheel Speed Sensor Removal – Front Axle

To remove the sensor from the front axle:

! WARNING

Park the vehicle on a level surface. Block the wheels to prevent the vehicle from moving. Support the vehicle with safety stands. Do not work under a vehicle supported only by jacks. Jacks can slip and fall over. Serious personal injury can result.

1. Put blocks under the rear tires to stop the vehicle from moving. Apply the parking brake.
2. If necessary, raise the front tires off the ground. Put safety stands under the axle.
3. Disconnect the fasteners that hold the sensor cable to other components.
4. Disconnect the sensor cable from the chassis harness.
5. Remove the sensor from the sensor holder. Use a twisting motion if necessary. **Do not pull on the cable. Figure 4.1.**

Figure 4.1

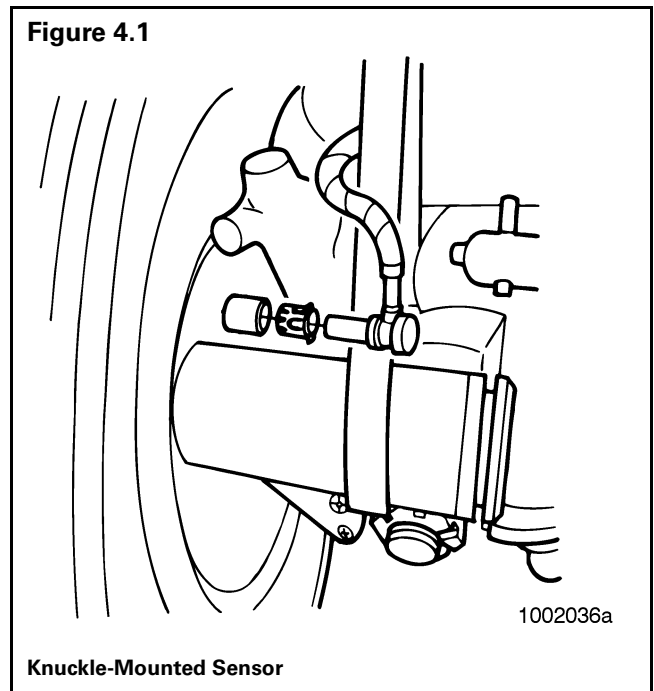

Section 4 Component Replacement

WABCO

Wheel Speed Sensor Installation — Front Axle

To replace the sensor in the **front axle**:

1. Connect the sensor cable to the chassis harness.
2. Install the fasteners used to hold the sensor cable in place.
3. Apply a WABCO recommended lubricant to the sensor spring clip and sensor.
4. Install the sensor spring clip. Make sure the spring clip tabs are on the inboard side of the vehicle.
5. Push the sensor spring clip into the bushing in the steering knuckle until the clip stops.
6. Push the sensor completely into the sensor spring clip until it contacts the tooth wheel.

NOTE: After installation, there should be no gap between the sensor and the tooth wheel. During normal operation, a gap of up to 0.04-inch is allowable.

7. Remove the blocks and safety stands.

Wheel Speed Sensor Removal — Rear Axle

To remove the sensor from the **rear axle**:



WARNING

Park the vehicle on a level surface. Block the wheels to prevent the vehicle from moving. Support the vehicle with safety stands. Do not work under a vehicle supported only by jacks. Jacks can slip and fall over. Serious personal injury can result.

1. Put blocks under the front tires to stop the vehicle from moving.
2. Raise the rear tire off the ground. Put safety stands under the axle.
3. Release the parking brake and back off the slack adjuster to release the brake shoes.
4. Remove the wheel and tire assembly from the axle.
5. Remove the brake drum.
6. Remove the sensor from the mounting block in the axle housing. Use a twisting motion if necessary. **Do not pull on the cable.**
7. Remove the sensor spring clip from the mounting block.

8. Disconnect the fasteners that hold the sensor cable and the hose clamp to other components.
9. Disconnect the sensor cable from the chassis harness.

Wheel Speed Sensor Installation — Rear Axle

1. Apply a WABCO recommended lubricant to the sensor spring clip and sensor.
2. Install the sensor spring clip. Make sure the spring clip tabs are on the inboard side of the vehicle.
3. Push the sensor spring clip into the mounting block until it stops.

NOTE: After installation, there should be no gap between the sensor and the tooth wheel. During normal operation, a gap of up to 0.04-inch is allowable.

4. Push the sensor completely into the sensor spring clip until it contacts the tooth wheel.
- Figure 4.2.**

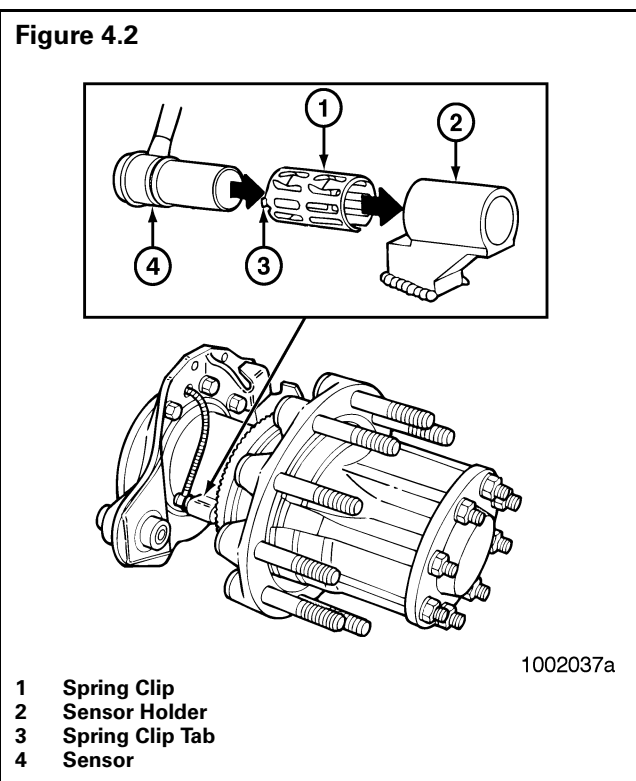

5. Insert the sensor cable through the hole in the spider and axle housing flange. Route the cable to the frame rail. Be sure to route the cable in a way that will prevent pinching or chafing and will allow sufficient movement for suspension travel.
6. Connect the sensor cable to the chassis harness.
7. Install the fasteners that hold the sensor cable in place.
8. Install the brake drum on the wheel hub.
9. Complete the installation per vehicle manufacturer's manual.

Valves

ABS Modulator Valve

Removal

1. Turn ignition switch to the OFF position, apply parking brake.



WARNING

Park the vehicle on a level surface. Block the wheels to prevent the vehicle from moving. Support the vehicle with safety stands. Do not work under a vehicle supported only by jacks. Jacks can slip and fall over. Serious personal injury can result.

2. Put blocks under the front and rear tires to stop the vehicle from moving.
3. If necessary, raise the vehicle off the ground and put safety stands under the axle.
4. Disconnect the wiring connector from the ABS valve.
5. Disconnect the air lines from Ports 1 (air supply) and 2 (air discharge) of the ABS valve. **Figure 4.3.**

Figure 4.3

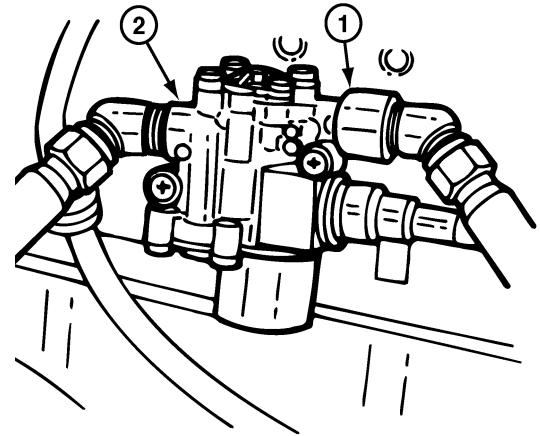

1002038a

- 1 Port 1 (Air In)
- 2 Port 2 (Air Out)

6. Remove the two mounting capscrews and nuts.
7. Remove the ABS valve.

Installation



CAUTION

Moisture can affect the performance of all ABS/ATC systems, as well as the standard braking system. Moisture in air lines can cause air lines to freeze in cold weather.

To install the ABS modulator valve:

1. Install the ABS valve with two mounting capscrews and nuts. Tighten the capscrews per the manufacturer's recommendation.
2. Connect the line to the brake chambers to Port 2 of the ABS valve. Connect the air supply line to Port 1 of the ABS valve.
3. Connect the wiring connector to the ABS valve. Hand tighten only.
4. Remove the blocks and stands.
5. Test the installation. (Refer to the following procedures.)

Section 4 Component Replacement

WABCO

Checking the Installation

To test the modulator valve:

1. Apply the brakes. Listen for leaks at the modulator valve.
2. Turn the ignition on and listen to the modulator valve cycle. If the valve fails to cycle, check the electrical cable connection. Make repairs as needed.
3. Drive the vehicle. Verify that the ABS indicator lamp operates properly.

ATC Valve

Removal

1. Turn ignition switch to the OFF position. Apply parking brake.



WARNING

Park the vehicle on a level surface. Block the wheels to prevent the vehicle from moving. Support the vehicle with safety stands. Do not work under a vehicle supported only by jacks. Jacks can slip and fall over. Serious personal injury can result.

2. Put blocks under the front and rear tires to stop the vehicle from moving.
3. If necessary, raise the vehicle off the ground. Put safety stands under the axle.
4. **Relieve line pressure by bleeding the air from the appropriate supply tank.**
5. Disconnect the wiring from the ATC valve.
6. Disconnect the air lines from Port 1 (air supply), Port 2 (air discharge), and Port 3 (treadle) of the ATC valve. **Figure 4.4.**

Figure 4.4

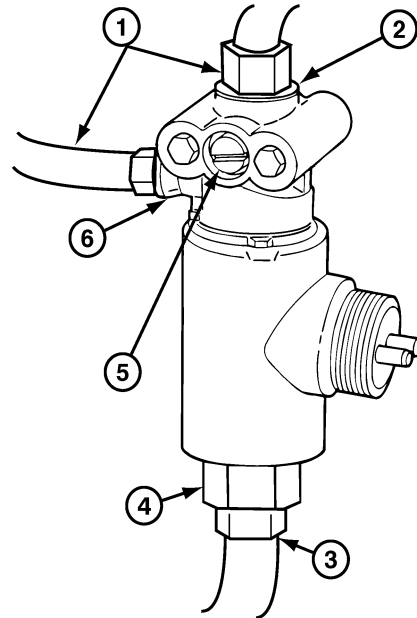

1002039a

- 1 Air Lines
- 2 Port 1 (Air Supply)
- 3 Air Line
- 4 Port 3 (Treadle)
- 5 Valve Control Do Not Open
- 6 Port 2 (Air Discharge)

7. Remove the two mounting capscrews and nuts. Remove the ATC valve.

Installation

1. Install the ATC valve with two mounting capscrews and nuts.
Tighten the capscrews per the manufacturer's recommendation.
2. Connect the air supply, discharge, and treadle lines to Ports 1, 2, and 3 of the ATC valve.
3. Connect the harness connector to the ATC valve. Hand tighten only.
4. Remove blocks and stands.
5. Test the installation. (Refer to the following.)

Checking the Installation

To test the ATC valve:

1. Start vehicle.
2. Fully charge reservoirs with air. Shut off vehicle.
3. Apply brakes.
4. Listen for air leaks at ATC valve.
5. Release brakes.
6. Activate ATC valve using the MPSI tool.
7. Disconnect MPSI tool.
8. Drive the vehicle. Verify that the ATC indicator lamp operates properly.

Front or Rear ABS Valve Package

**Removal and Replacement —
Complete Package**

Figure 4.5: Front ABS Valve Package

Figure 4.6: Rear ABS Valve Package

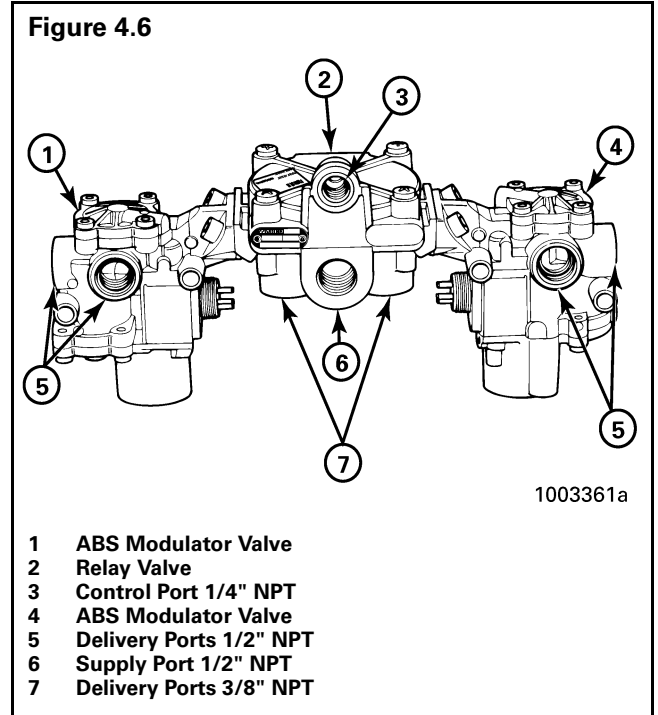
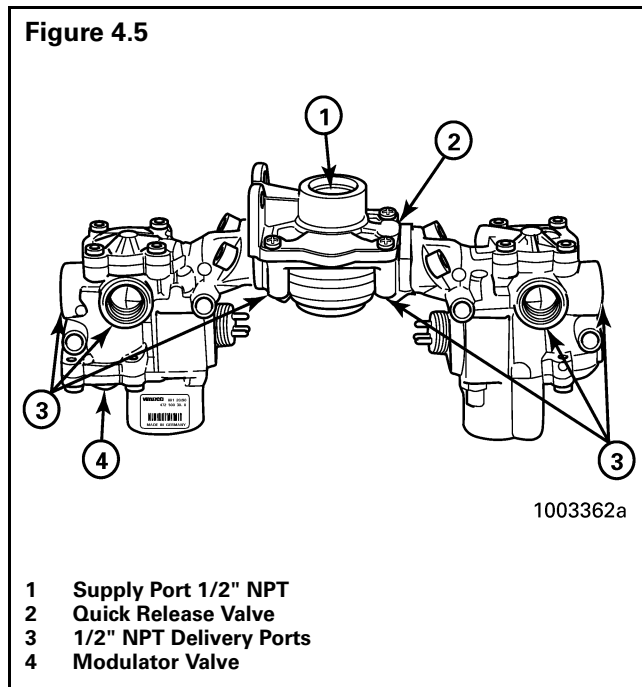

! WARNING

Park the vehicle on a level surface. Block the wheels to prevent the vehicle from moving. Support the vehicle with safety stands. Do not work under a vehicle supported only by jacks. Jacks can slip and fall over. Serious personal injury can result.

1. Put blocks under tires to stop the vehicle from moving.
2. If necessary, raise the tires off the ground.
3. Drain air from all system air tanks.
4. Remove all air lines and connections from ABS valve package.
5. Remove mounting bolts from the valve package — remove the valve package from vehicle.
6. **Replace the ABS valve package:** Tighten bolts to OE recommendation. Remove blocks and safety stands as necessary.
7. Test the installation. (Refer to page 38.)

Section 4 Component Replacement

WABCO

Removal and Replacement — Component Valves

(Refer to Figure 4.7)

1. Remove ABS valve package from vehicle.
2. Use a 6 mm Allen wrench to loosen and remove the Allen head bolts.

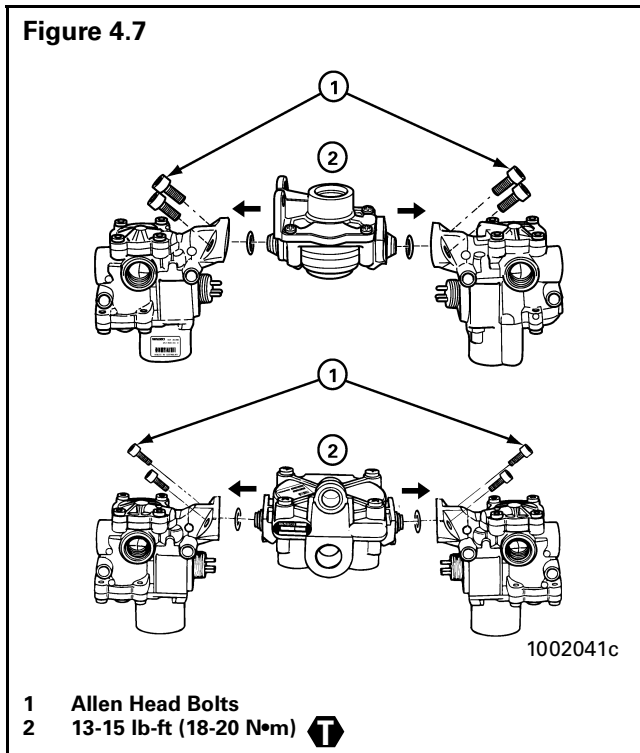

3. Carefully separate ABS modulator valve(s) from the relay or quick release valve.
4. Remove and discard old O-rings. Lubricate replacement O-rings with grease provided.
5. Plug any unused ports on the replacement valve(s).
6. Attach ABS modulator valve(s) to the relay valve. Torque the Allen head bolts to 13-15 lb-ft (18-20 N•m). 
7. **Replace the ABS valve package:** Tighten bolts to OE recommendation. Remove blocks and safety stands as necessary.

8. Check the valves for leaks:
 - Modulator valve(s) (Refer to page 31.)
 - Relay or quick release valve (Refer to page 34.)

ATC Valve on the Rear ABS Valve Package

Removal

NOTE: If there is enough room to work, it is not necessary to remove the valve package from the vehicle before replacing the ATC valve. If the valve package must be removed, follow the instructions for removing and replacing the ABS Valve Package that appear in this section of the manual.

When installing the new ATC valve on the valve package, you must use the new O-rings, seals, mounting bolts, and lubricant included with the replacement kit.

1. Turn ignition switch to the OFF position, apply parking brake.

WARNING

Park the vehicle on a level surface. Block the wheels to prevent the vehicle from moving. Support the vehicle with safety stands. Do not work under a vehicle supported only by jacks. Jacks can slip and fall over. Serious personal injury can result.

2. Put blocks under the front and rear tires to stop the vehicle from moving.
3. If necessary, raise the vehicle off the ground. Put safety stands under the axle.
4. **Relieve line pressure by bleeding the air from the appropriate supply tank.**
5. Disconnect the wiring from the ATC valve.
6. Disconnect supply air line from the adapter and the treadle air line from the ATC valve.

- Use a 5 mm Allen wrench to remove the two screws that hold the adapter piece to the relay valve portion of the valve package.

Use a 6 mm Allen wrench to remove the two mounting bolts that hold the ATC valve to the adapter piece. Remove the ATC valve from the adapter piece. Remove the ATC valve.

Remove the adapter piece, seal, and O-rings from the valve package. **Figure 4.8.**

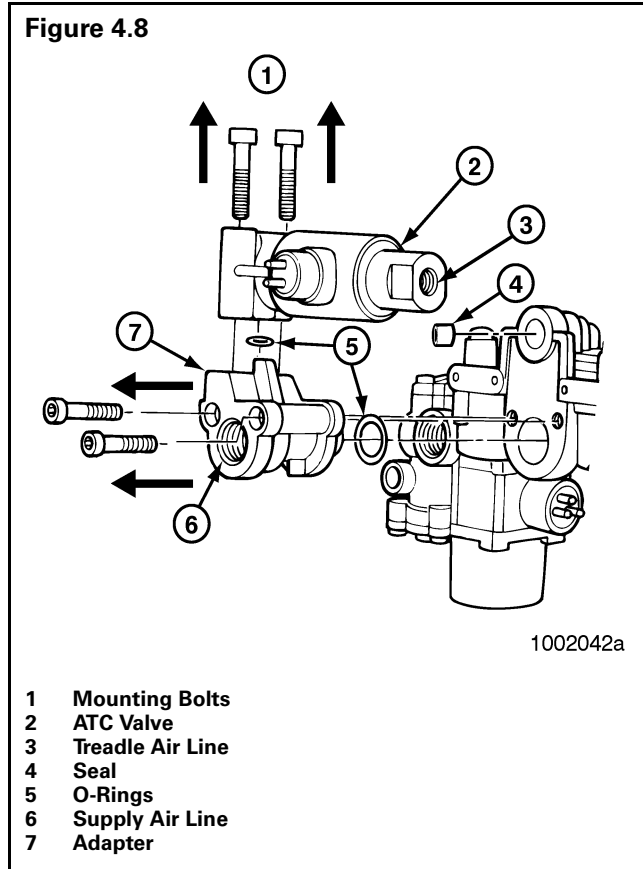

Installation

- Clean and lubricate the small adapter piece O-ring. Install O-ring on adapter piece.
Use the two new M8 Allen head bolts to attach the ATC valve to the adapter piece. Use a 6 mm Allen head tool to tighten to 12-13 lb-ft (18-20 N•m) **Figure 4.9.**

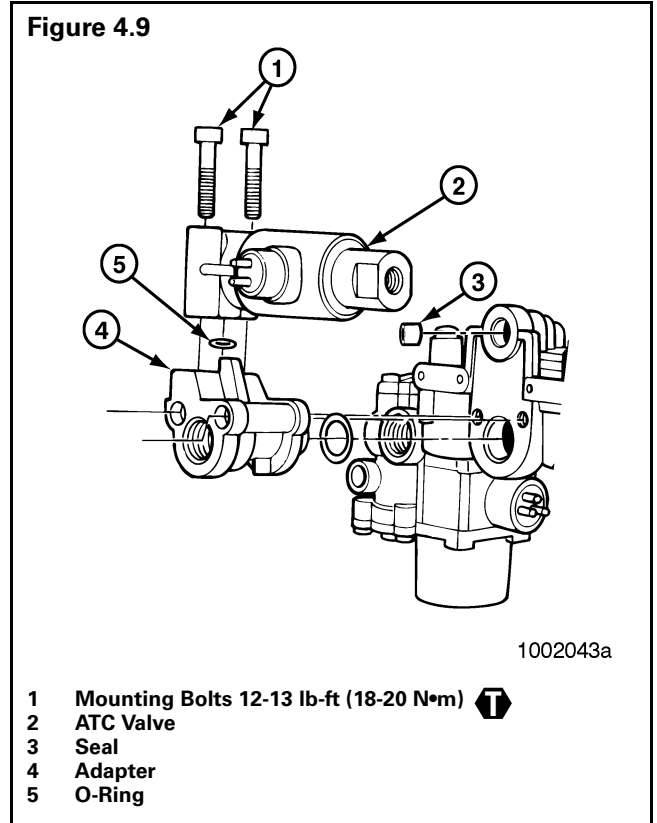

- Lubricate the replacement seal and install it in Port 2 of the ATC valve.
Lubricate the large replacement O-ring and install it in the groove of the relay valve supply port. **Figure 4.10.**

NOTE: Use WABCO-recommended lubricant.

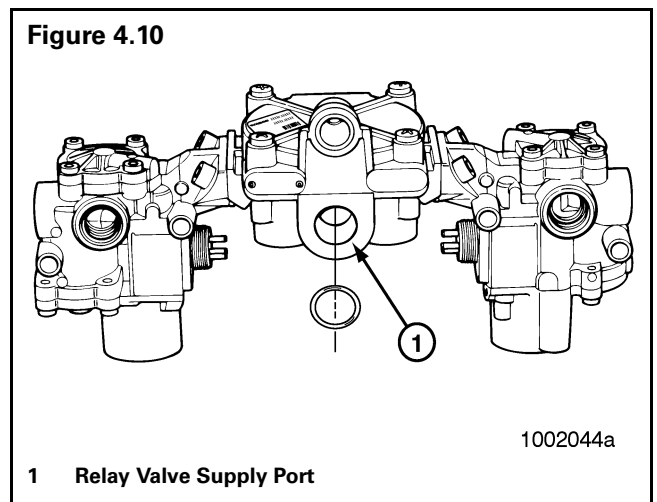

Section 4 Component Replacement

WABCO

3. Use the two M6 Allen head bolts to attach the adapter to the relay valve. Use a 5 mm Allen head tool to tighten to 4-5 lb-ft (6-8 N•m).

Figure 4.11. 

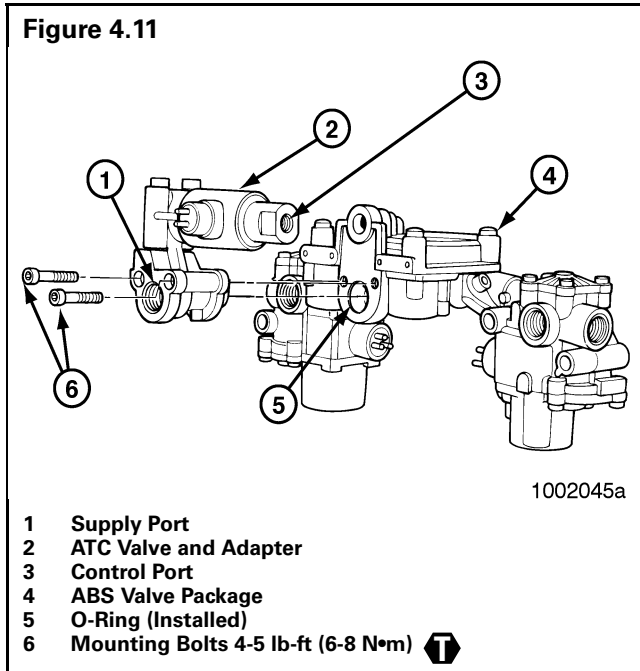

4. Connect the supply air line to the supply port on the adapter. Connect the treadle air line to the control port on the ATC valve.
5. Attach the wiring connector to the ATC valve. Hand tighten only.
6. Remove blocks and stands.
7. Test the installation. (Refer to below.)

Checking the Installation

To test the valves:

1. Start vehicle.
2. Fully charge reservoirs with air. Shut off vehicle.
3. Apply brakes.
4. Listen for air leaks at all valves.
5. Drive the vehicle. Verify that the ABS indicator lamp operates properly.

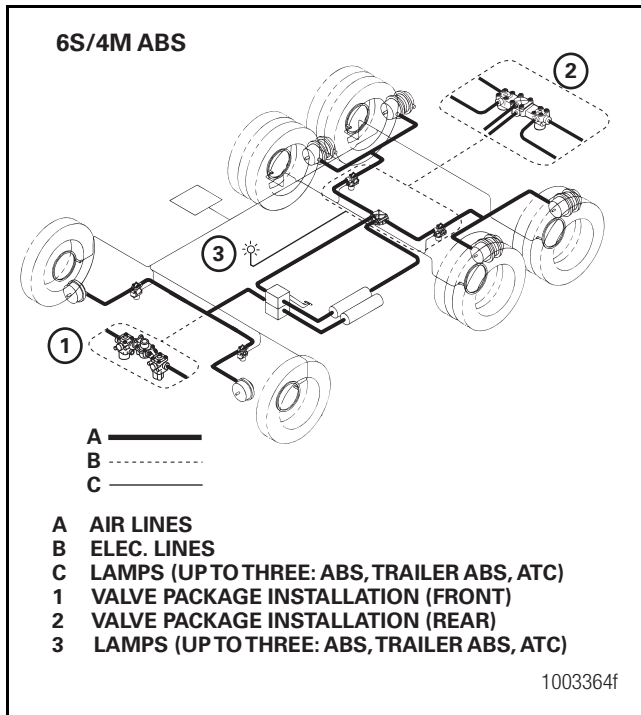
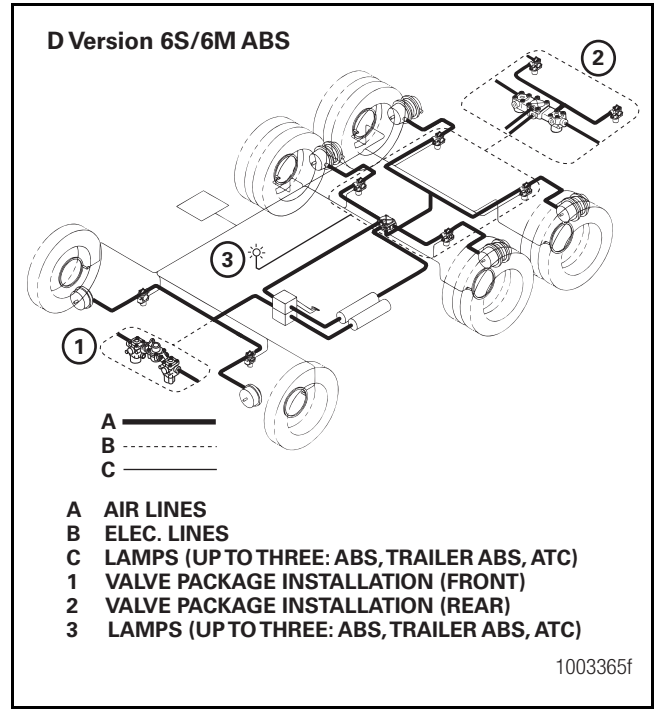
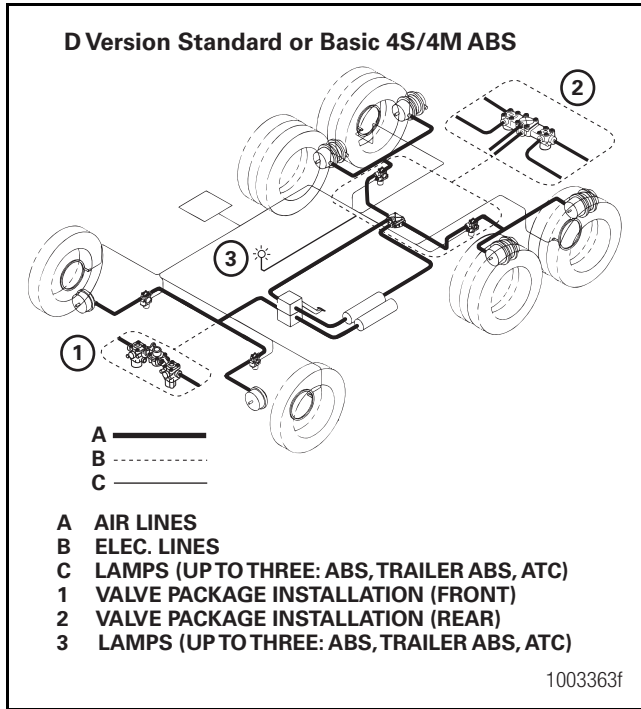

Appendix I System Configuration Layouts

WABCO

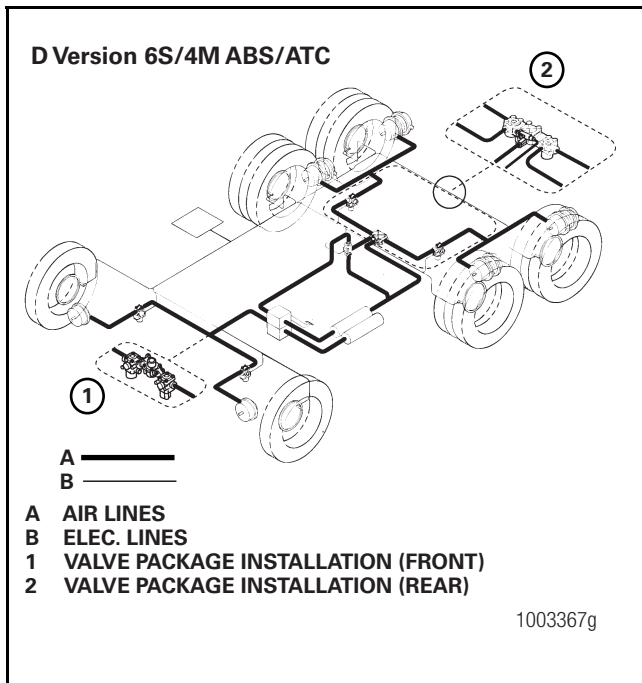
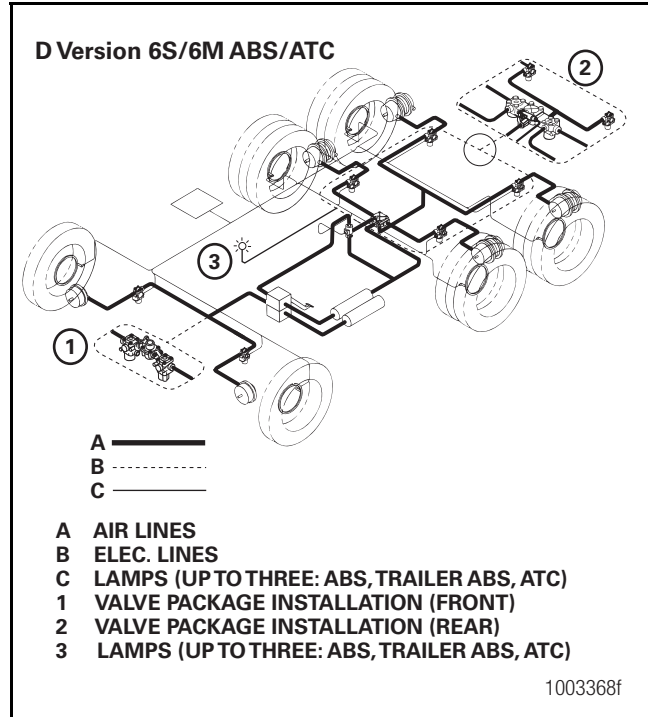
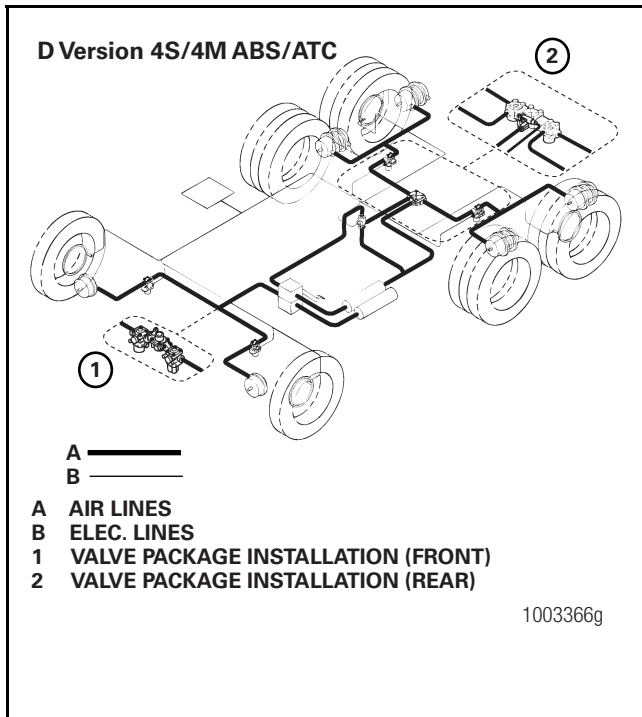

- **D Basic ECU (Cab-Mounted)**
- **D Version Cab-Mounted ABS/ATC ECU**
- **D Version Frame-Mounted ABS/ATC ECU**

D Basic ECU — All D Basic ECUs Are Cab-Mounted

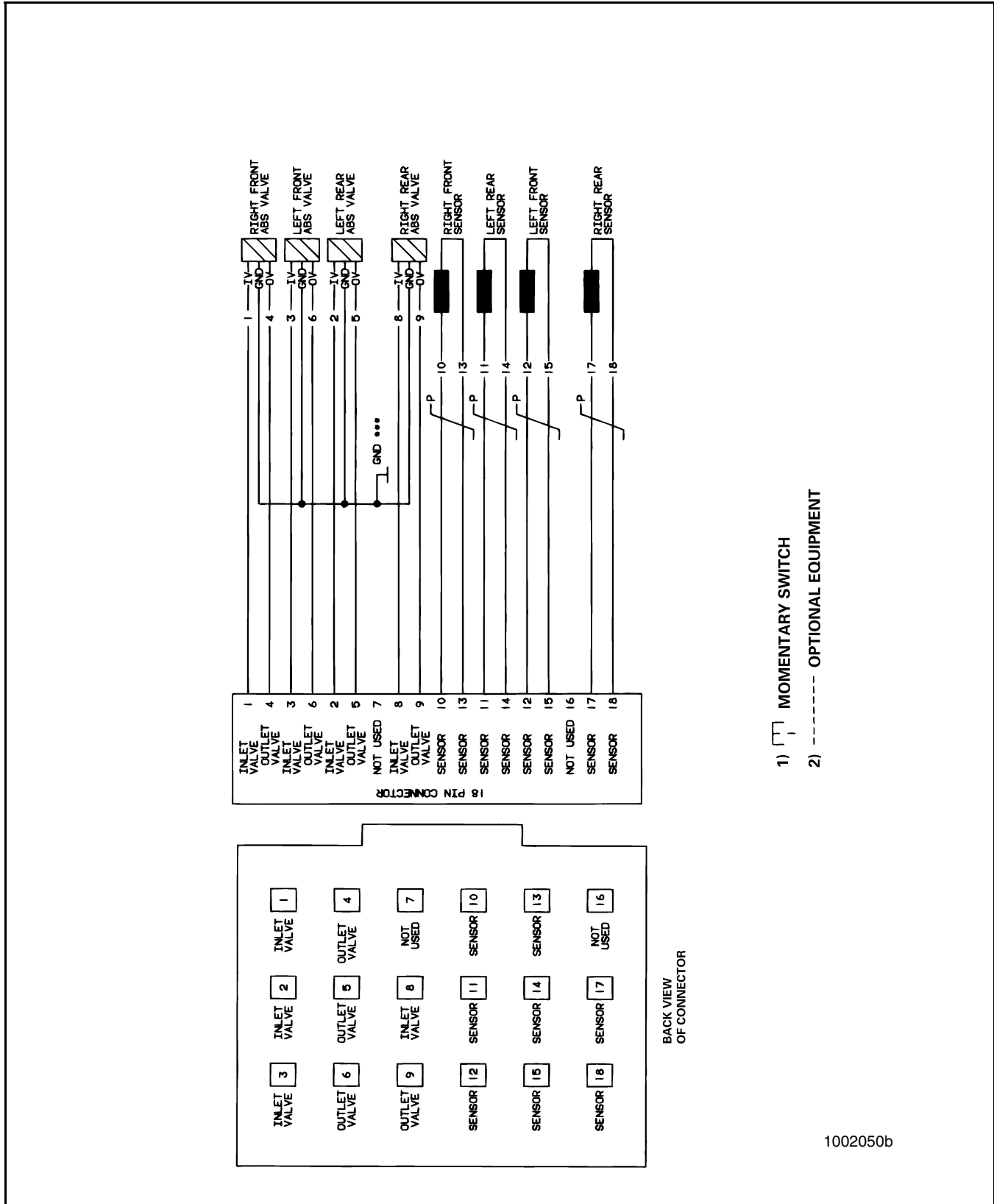

1002050b

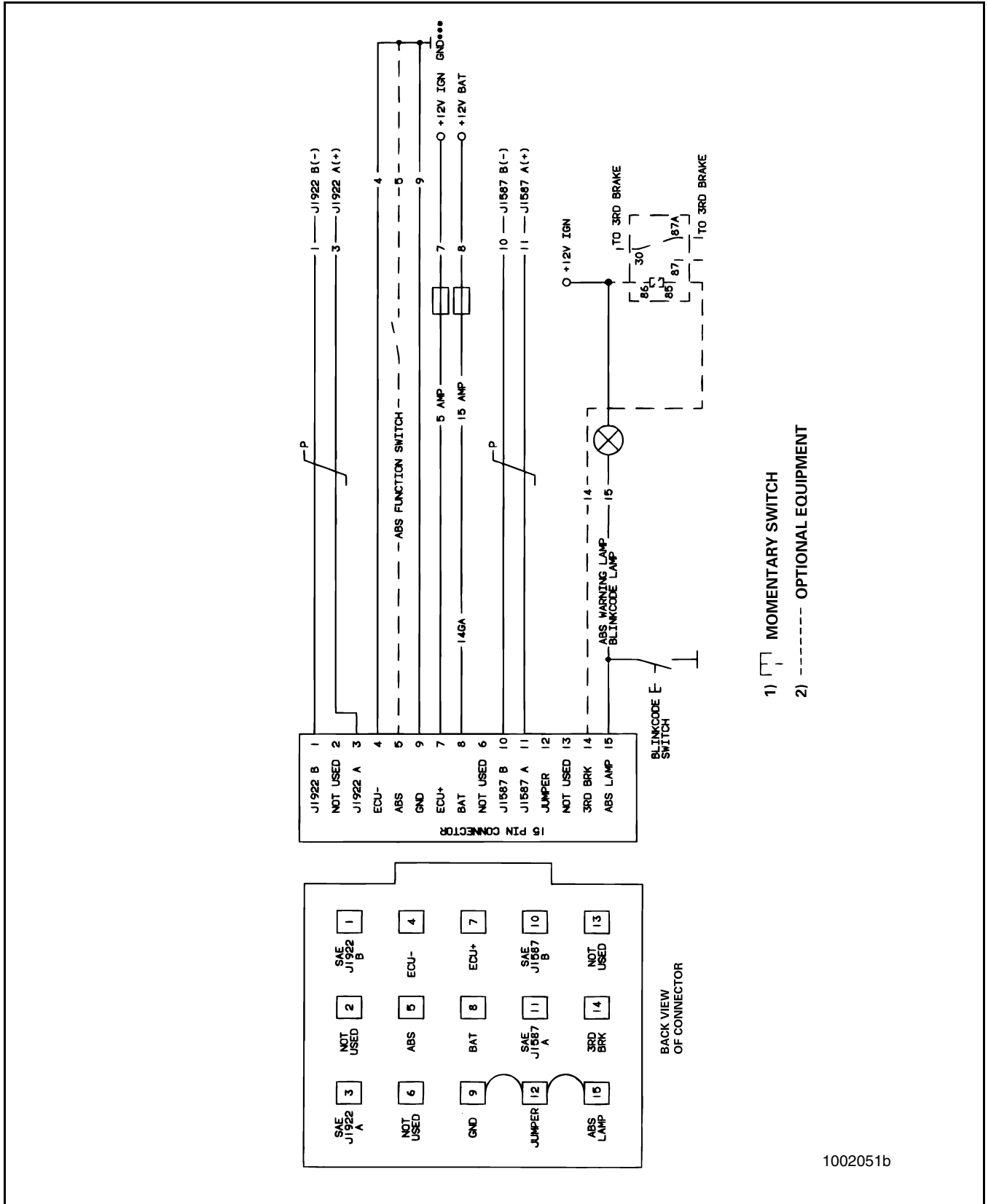

1002051b

Appendix II Wiring Diagrams

WABCO

D Version Cab-Mounted ABS/ATC ECU

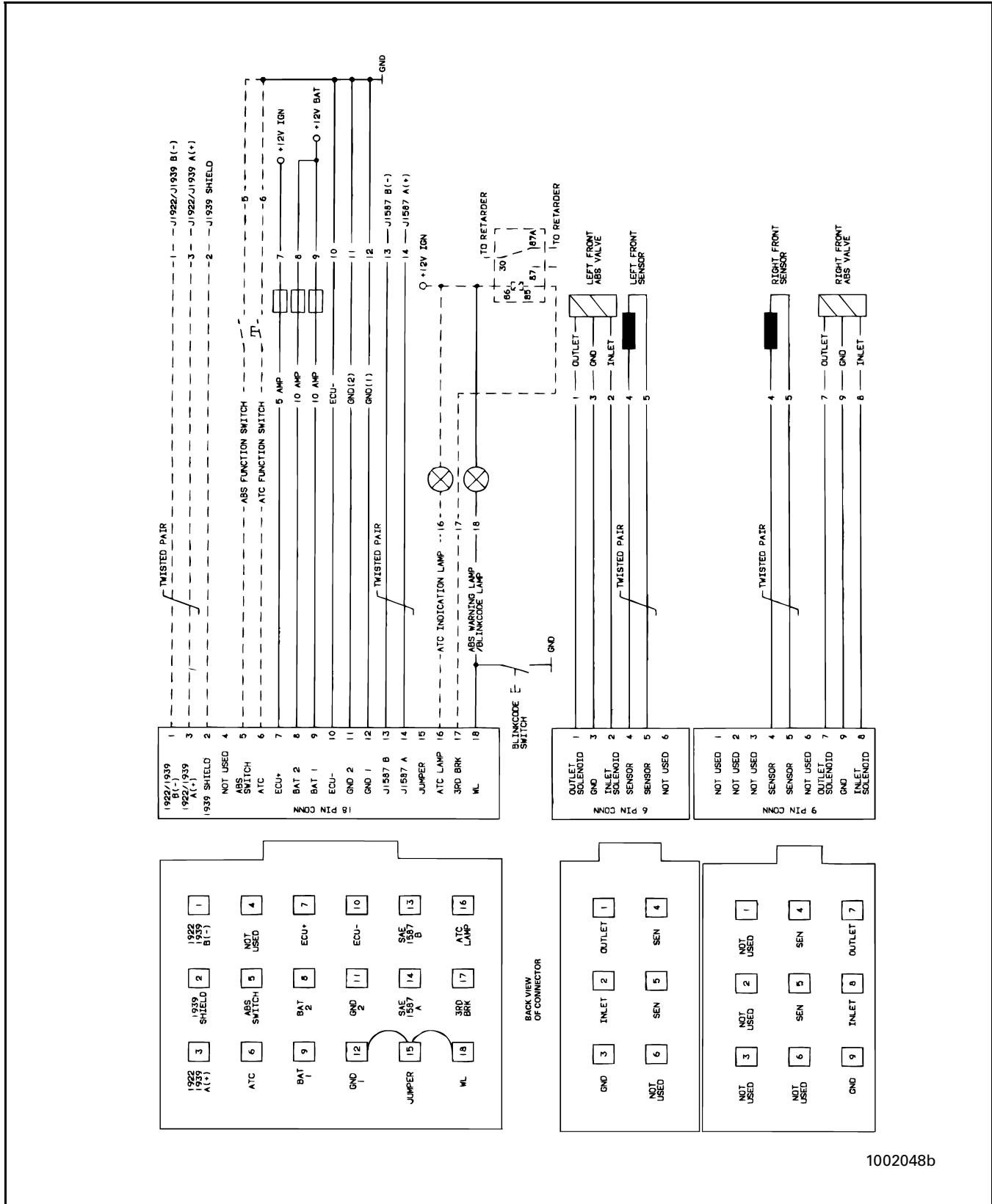

1002048b

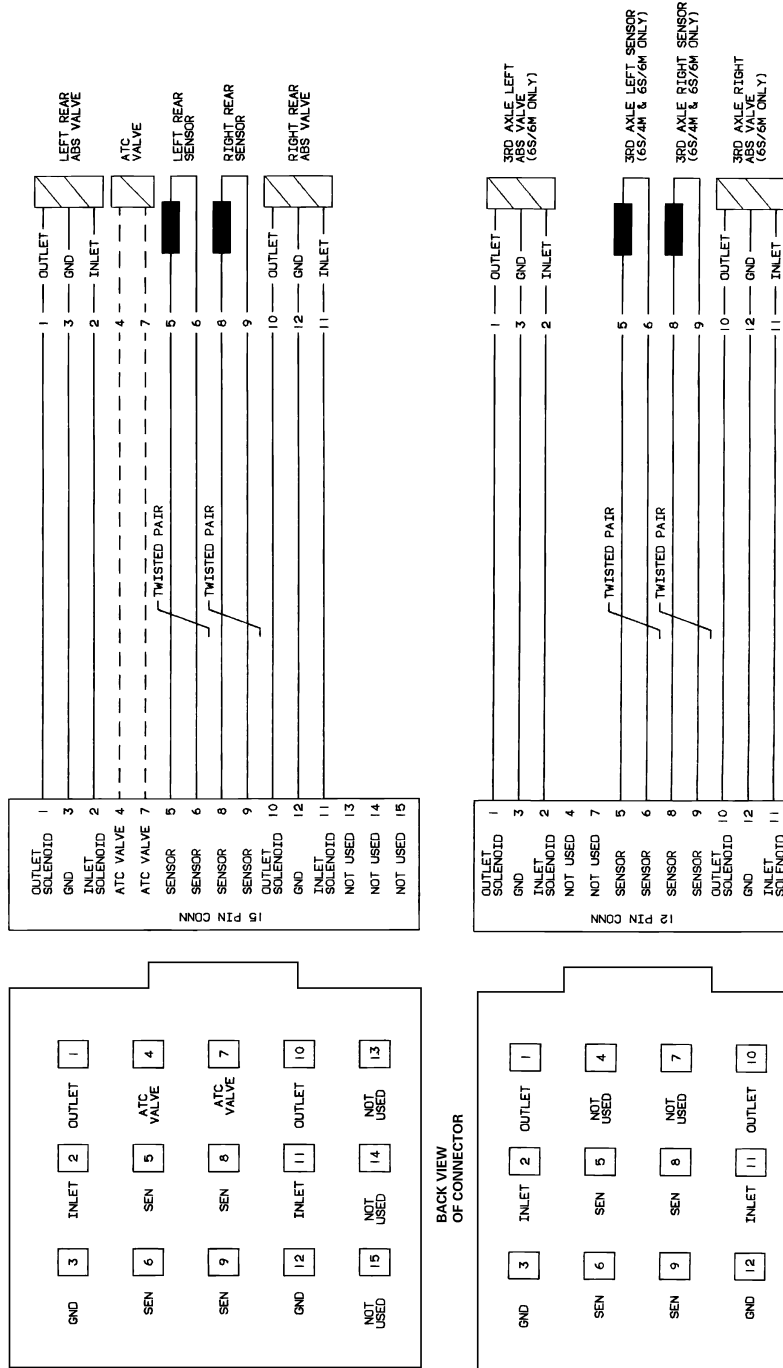

1002049b

D Version Frame-Mounted ABS/ATC ECU

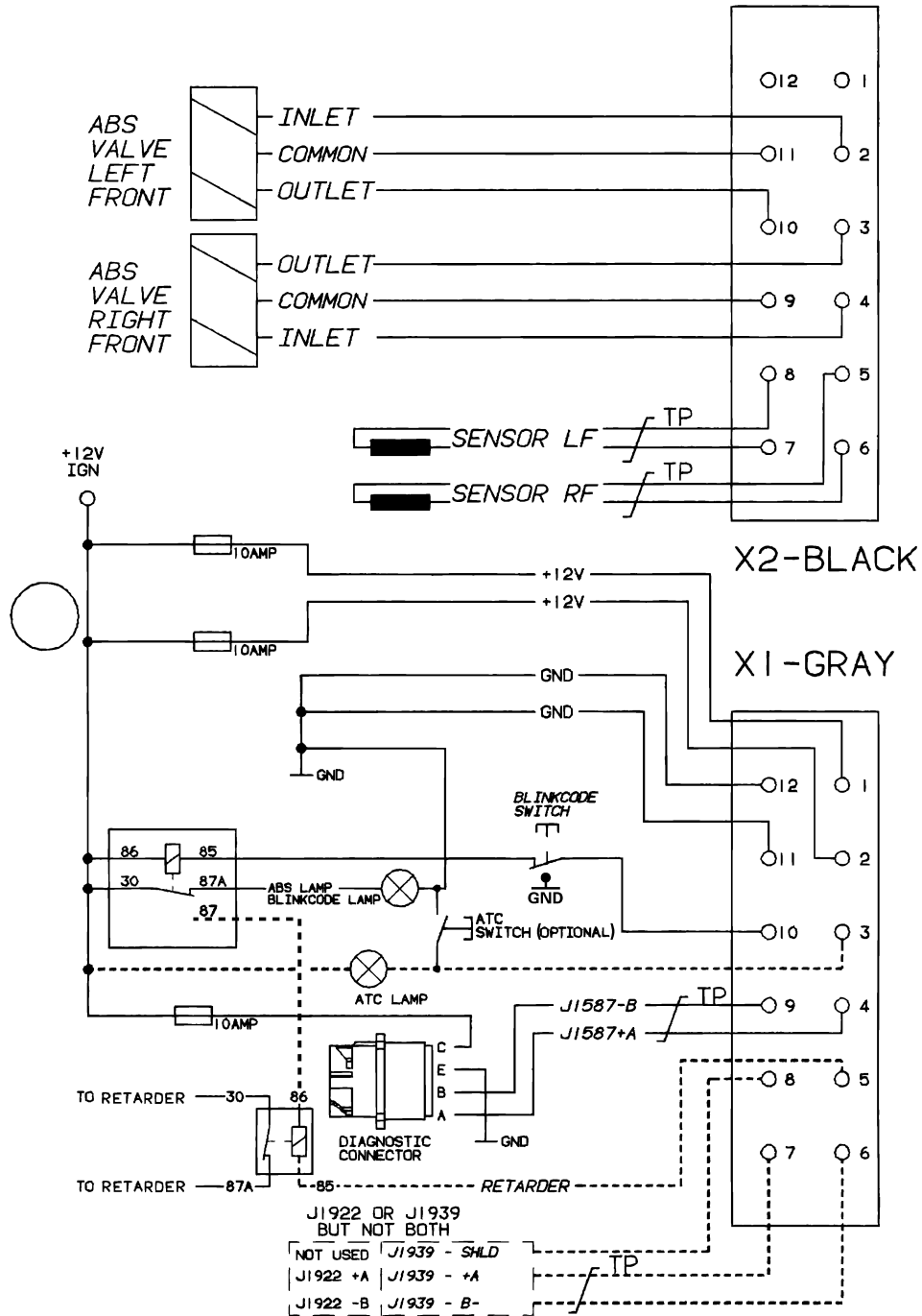

1002052b

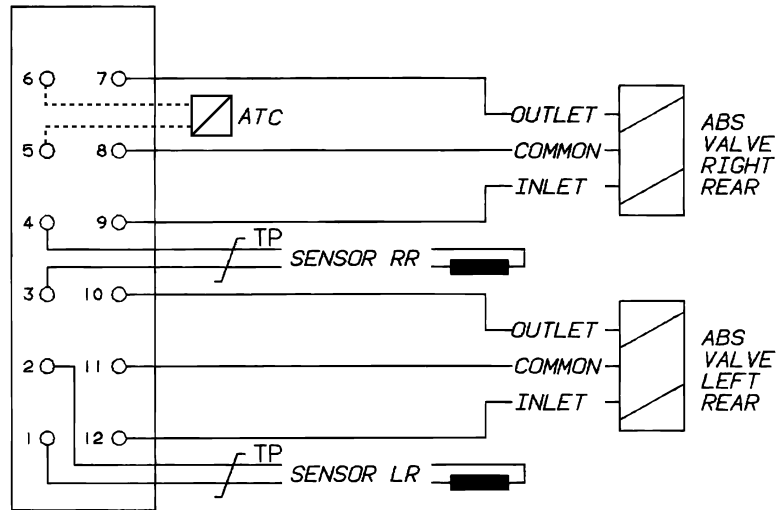

X3-GREEN

X4-BROWN (ONLY FOR 6 CHANNEL)

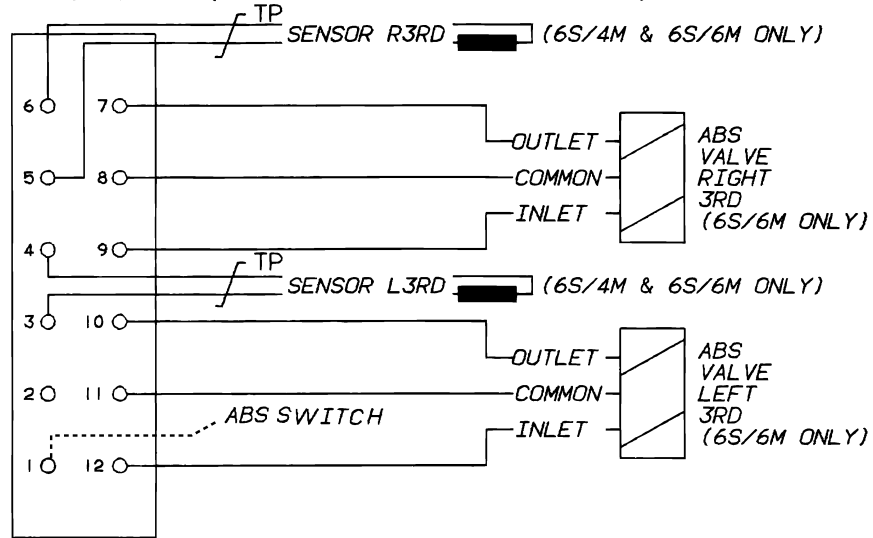

- 1) ----- OPTIONAL EQUIPMENT
- 2) TP = TWISTED PAIR

1002053b

Troubleshooting Guide – WABCO ABS Valve Package

This Troubleshooting Guide is a reference tool to help identify possible malfunctions of the ABS modulator or relay valves. It does not take the place of diagnostic tests or other service instructions.

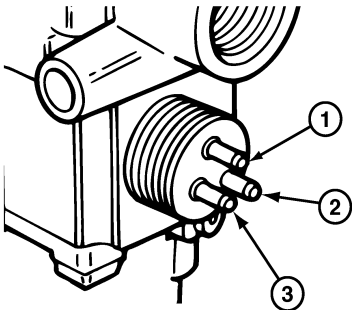
| ABS Valve Package Troubleshooting Guide | | |
|---|--|---|
| Condition | Possible Cause | Recommended Action |
| Air constantly leaks from exhaust port of relay valve. | Internal relay valve problem. | <ul style="list-style-type: none"> Replace the relay valve. |
| Air leaks from exhaust port of ABS modulator valve or relay valve when parking brake is released. | Parking brake problem. or Anti-compound 2-way check valve problem. | <ul style="list-style-type: none"> Service appropriate component. <ul style="list-style-type: none"> Refer to manufacturer's service manual for instructions. |
| Rear service brakes releasing slowly (brakes dragging). | Kinked air line. Dirt buildup inside relay valve. | <ul style="list-style-type: none"> Inspect/repair lines, brakes. <p>If condition is not corrected:</p> <ul style="list-style-type: none"> Replace relay valve. |
| Valves don't cycle at power-up. or Indicator lamp comes on (blink code or diagnostic tool indicates electrical problem with ABS valve). | Broken wire. or Loose or broken terminal connection. Corroded connector pins. or Problem with solenoid. | <ul style="list-style-type: none"> Check wires and connections. <ul style="list-style-type: none"> Make repairs as needed. <p>If condition is not corrected:</p> <ul style="list-style-type: none"> Measure resistance across each valve solenoid coil terminal and ground on the ABS modulator valve to ensure 4.0 to 9.0 ohms. <ul style="list-style-type: none"> If greater than 9.0 ohms, replace ABS modulator valve. If cleaning does not solve problem, replace the ABS modulator valve. <ul style="list-style-type: none"> If less than 4.0 ohms, replace ABS modulator valve. |
|  <p>1 Ground Terminal 2 Exhaust Solenoid (blue wire) 3 Inlet Solenoid (brown wire)</p> | <ul style="list-style-type: none"> Road Hazards. or Vehicle Damage. | <ul style="list-style-type: none"> Replace complete ABS valve package or individual component as required. |
| ABS valve package damaged. | <ul style="list-style-type: none"> Road Hazards. or Vehicle Damage. | <ul style="list-style-type: none"> Replace complete ABS valve package or individual component as required. |

Reconfiguration Procedure

How to Reconfigure an ECU (D Version)

Before reconfiguring the ECU, contact WABCO North America Customer Care at 855-228-3203 for additional information.

Once these components have been memorized, the ECU will look for them at each power-up. If a memorized component is not present, the ECU will record a fault. For example, if an ATC valve is memorized, but is not present at the next power-up, the ECU records a fault. This can occur if an ECU is moved from one truck to another and one or more of the memorized components are not available on the new truck. If this occurs, follow these steps to reconfigure the ECU.

D version ECUs memorize the following components if they are connected at power-up:

- ATC valve
- Retarder relay
- Datalink SAE J1922 or SAE J1939

| Action | Result | Reason |
|--|---|--|
| 1 Turn ignition ON . 2 Press and hold blink switch for at least three seconds. NOTE: Do not hold this switch longer than seven seconds. | ABS lamp displays the ABS system configuration code*: <ul style="list-style-type: none"> • One blink: 6S/6M • Two blinks: 4S/4M • Four blinks: 6S/4M * The ABS lamp may display eight quick flashes before the system configuration code begins. | Stored faults cleared, no active faults present. Continue with reconfiguration. NOTE: The reconfiguration procedure can not be conducted if there are active faults present. These must be repaired before proceeding with the reconfiguration. |
| Observe the ABS and ATC lamps. | ATC lamp comes on and stays on. | A complete ATC system — including an ATC lamp — is installed. If not, the ATC lamp will not come on. |
| | ABS lamp will continuously blink the system configuration code. | ECU reconfiguring the system. The ECU checks the following components and reprograms itself based on the new system: <ul style="list-style-type: none"> • ATC valve AND/OR • Retarder relay AND/OR • Datalink SAE J1922 or J1939 |
| While the configuration code is flashing, press the blink code switch three times (one second each, with a one second pause between each). Turn ignition OFF . | ABS lamp displays four quick flashes , followed by a continuous display of the system configuration code. NOTE: System configuration code continues until ignition is turned OFF. | Successfully reconfigured. |

Appendix III Additional ABS Information

A system reconfiguration is illustrated below:

IGNITION ON

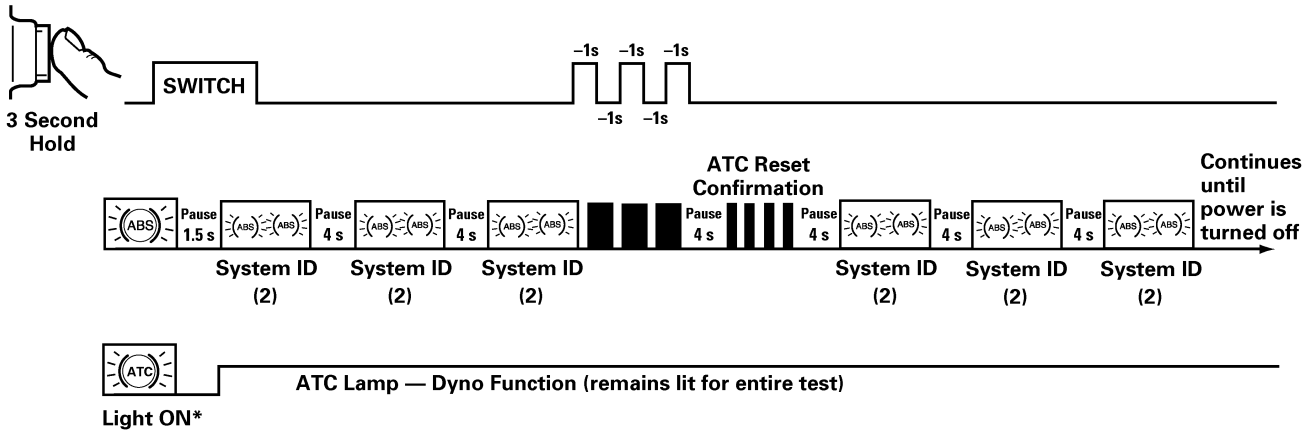

*ATC Lamp will light only if ATC is connected.

1003371a



WABCO
a **WORLD** of
DIFFERENCE

WABCO (NYSE: WBC) is a leading global supplier of technologies and services that improve the safety, efficiency and connectivity of commercial vehicles. Founded nearly 150 years ago, WABCO continues to pioneer breakthrough innovations for advanced driver assistance, braking, stability control, suspension, transmission automation and aerodynamics. Partnering with the transportation industry as it maps a route toward autonomous driving, WABCO also uniquely

connects trucks, trailers, cargo, drivers, business partners and fleet operators through advanced fleet management systems and mobile solutions. WABCO reported sales of \$2.8 billion in 2016. Headquartered in Brussels, Belgium, WABCO has 13,000 employees in 40 countries. For more information, visit:

www.wabco-na.com

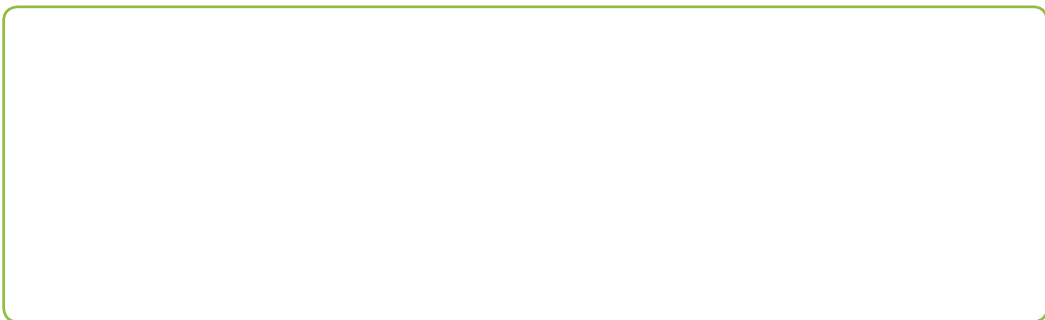

WABCO